

PARAMETRIC URBAN MODELS BASED ON FREI OTTO'S GENERATIVE FORM-FINDING PROCESSES

JOÃO V. LOPES¹, ALEXANDRA C. PAIO² and JOSÉ P. SOUSA³

^{1,2} *VitruviusFablab/ADETTI/ISCTE University Institute of Lisboa, Lisbon, Portugal*

{jvls, alexandra.paio}@iscte-iul.pt

³ *DFL/CEAU/FAUP University of Porto, Porto, Portugal*
jsousa@arq.up.pt

Abstract. Presently there is a progressive tendency to incorporate parametric design strategies in urban planning and design. Although the computational technologies that allow it are recent, fundamental theories and thinking processes behind it can be traced back to the work conducted at the Institute for Lightweight Structures (IL) in Stuttgart, between the 1960's and 1980's. This paper describes an experimental urban research work based on Frei Otto and Eda Schaur's thoughts on unplanned settlements, and on the form-finding experiences carried out at IL. By exploring the digital development of parametric and algorithmic interactive models, two urban design proposals were developed for a site in Porto city. Out of this experience, this paper suggests that today the act of design can benefit from a deeper understanding of the natural processes of occupation and connection.

Keywords. Parametric urbanism; generative design; form-finding; Frei Otto.

1. Introduction

The dissemination of new rule-based design processes supported by scripting, is allowing the parameterization of form and the simulation of dynamic processes. As a result, the computer becomes a virtual lab and a creatively used generative design tool. In urban design, Schumacher, quoted by Silva and Amorim (2010, pp. 15-16), argues that innovation can only be achieved since "the scripts allow you to program design tools to handle a large number of parameters and create a design sensitive to the formal parameters, functional and environmental". In comparison with other disciplines, Steino

(2010) points out that the adoption of these new parametric tools in urban design is still in its *relative infancy*. By referring to Schumacher's theories, Silva and Amorim also suggest that parametric urbanism is conceptually based on the contemporary notion of space which, as a basic urban conception and in contrast to the modern and postmodern ones, is now understood as *Field*: the spacialization of multi-scale latent information flows crossing a pre-existent place. The city is thus perceived as an ecosystem where the interaction of dynamic and decentralized forces draws its increasing complexity. It is in this context that, with the progressive availability of computational power and urban data resources, urban simulation and design practice tend to merge (Stolk, 2009). Through computational thinking and parametric and algorithmic design techniques, the current knowledge and analytic capabilities of emergent natural and urban patterns (Batty, 2005) achieve a generative capacity, making the *synthesizing of the vernacular* a motto for investigations of authors like Trummer (2008) or Coats (2010). This trend is recognized by Schumacher (2008) as a new all-embracing style - *Parametricism*. Although the author refers that the first manifestations may be depicted in Hadid's large-scale urban proposals of the 2000s, he claims that "Frei Otto might be considered the sole true precursor of parametricism" (2008, pp. 23).

Working at the Institute for Lightweight Structures (IL), within the framework of the research program SFB 230 "Natural Structures" (sub-project C2: "Natural Processes - House and Town"), the Otto (2011) and Schaur's (1992) theories on the structuring of space and unplanned settlements, and their *form-finding* experiments in self-generated structures, have inspired several investigations in architecture and urban design. Among them, it is important to refer Frick and Grabner's work (2012), which explored vector fields to represent environmental and socioeconomic parameters, and Georgiadou's thesis (2012) on complex urban networks generation, where the IL wet threads experiment was digitally simulated using different methods. In general, the digital emulation of IL's *form-finding* models results either from *chemical-behavioural* modelling by agents, or, more akin to Otto's thinking, from physical simulation of attractive-repulsive forces with spring-particle systems.

It is this last approach, more mathematical and geometrical, that was explored by the authors to investigate the application of the urban theory developed at IL in an urban design context. To do so, a set of generative and parametric algorithms were digitally developed in order to define interactive urban patterns for implementation and evaluation in real context. By describing and illustrating an on-going academic research project, this paper reflects on the potential of using digital *form-finding* strategies to deal with the complexity involved in urban design and planning.

2. Frei Otto and Eda Schaur theories and the IL form-finding models

Referring to his previous work developed at IL Frei Otto presents in *Occupying and Connecting* (2011) a theory about the phenomena of urban networks as self-organized systems, surfaces and paths occupations, and territories expansion. All these spontaneous structures grow through two basic processes that organize all natural and humanized spaces: occupation and connection. Governed by laws of attraction/repulsion or expansion/contraction, they present emergence and self-organization behaviour akin to physical processes in natural patterns. This familiarity was already exposed in Schaur's *IL39* (1992) through the study of unplanned human settlements and self-generated natural structures in the same grid of topological analysis. These phenomena were illustrated through examples extracted from the natural, social and technological worlds, and in a series of physical *form-finding* experiments, studied in IL between the 1960s and 1980s, using magnetized needles, bubbles, soap films, sandboxes or wet threads (Figure 1).

These experimental models of occupation and connection (path systems) are fundamental for the authors' research and are summarized below:

- **Repulsion or Distancing Occupation (magnetized needles model):** Experiments with floating magnetized needles. The balance of magnetic forces generates spontaneous triangular grids whose regularity increases with the increasing amount of needles.
- **Attraction Occupation (bubble packing model):** Experiments with a device that produces air or soap bubbles of constant dimension. These organize themselves in an optimal hexagonal packaging: the pattern formation process is similar to the above, except that this one reaches the highest density.
- **Simultaneous Repulsion and Attraction Occupation:** Model that combines the first two: small bubbles or polystyrene chips agglomerate around magnetized needles holding a repulsion occupation in a *D.L.A.* like process.
- **Direct path system:** Each pair of points is joined by the geodesic. It is a system in which transport is done without detour, and are no ramifications. As an idealization it is used as the minimized detour path models starting point.
- **Minimal path system (soap film model):** Connects a set of points along the shortest route (minimal Euclidean Steiner tree). In *IL1 Minimal Nets* (Otto, 1971) it is described an apparatus for the calculation of minimal paths through soap films. New points are generated (Steiner points) that are always nodes with 3 edges forming 120° angles between them.
- **Minimized detour path system (wet thread model):** The previous systems represent two extreme solutions, presenting great advantages as well as disadvantages in terms of length and detour. Schaur (1992) presents an experimental model for obtaining minimized detour path systems: a thread direct

path system is relaxed with an extra length, corresponding to the maximum allowed deviation, and then the structure is immersed in water whose surface tension forces the threads to bind and trunk, resulting in a shorter network. It combines the advantages of the previous two systems: length and detour are optimized, and a clearly recognizable group of self-generated shapes emerges, even though each experiment produces a distinct form.

The urban configurations modelled by the three path systems have different potentials depending on their cost regarding: (1) the area they occupy; (2) maintenance; (3) energy required for their use; and (4) promotion of social interaction. The minimized detour system is the one that offers the best balance between these factors (Schaur, 1992, pp. 50-51).

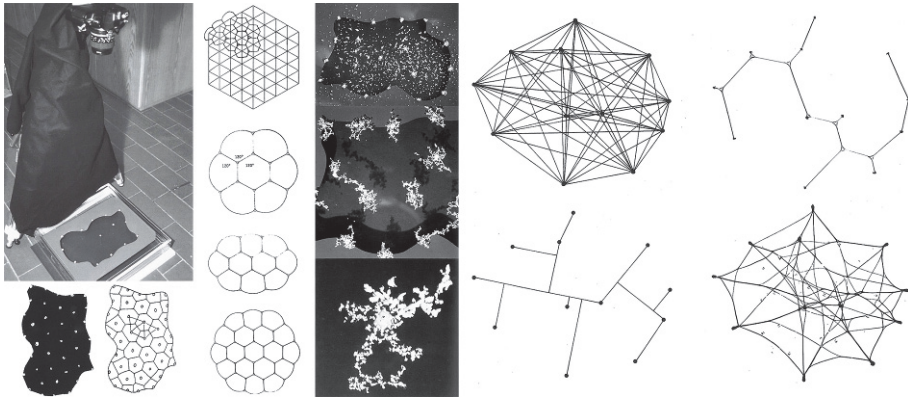

Figure 1. Experimental models of self-generating occupations and connections. Processes of occupation (taken from Otto, 2011) and connection - path systems (taken from Schaur, 1992).

3. Digital investigation: developing the parametric urban patterns

After reviewing the concepts and the physical experiments from IL, and surveying the recent investigations on their digital implementation, we selected to work with the generative and parametric environment of Rhinoceros with Grasshopper (McNeel & Associates) combined with the Kangaroo plugin (Daniel Piker) for physical calculation, interactive simulation, optimization and *form-finding*, and also the JAVA program FindSteinerTree (C. Klingenberg, Manchester University) for minimal paths calculation.

A series of generative-parametric patterns for urban design were created following Woodbury (2010, pp. 185-190) approach to parametric design using *patterns*. These are a way to consolidate and share knowledge, which echoes from Alexander's theories (1980) to programming by objects: *generic solutions to well-described problems*. The created urban patterns were di-

vided into four themes based on their description and application: Connect, Occupy, Analyse and Model. Initially studied abstractly, only the three most important ones were developed as a practical application to a parametric urban design workflow. These are:

- Pattern 1. Connect: minimized detour paths.
- Pattern 2. Connect: minimal paths.
- Pattern 3. Occupy: force occupations.

3.1. PATTERN 1. CONNECT: MINIMIZED DETOUR PATHS

The first pattern aims to digitally simulate the wet threads experiments through the use of Kangaroo (Figure 2). A negative value (i.e. attraction) of the *PowerLaw* force component (i.e. attraction or repulsion forces as a function of distance) was applied to a spring-particle system created from a set of initially segmented direct paths. The use of exponents of higher absolute value (e.g. -4, -5) simulates a steepest neighbourhood effect. As nearest actions cause more powerful reactions, the model creates bifurcation junctions from neighbouring segments, as the particles coalesce. The simulation particles may represent the vertices of line segments or the control points of higher degree NURBS curves, resulting in more "organic" curvilinear network shapes. The computation end occurs intentionally, when the interactions become very weak and the system starts to generate meshes with the typical overall areas of the local urban blocks. This pattern can be used to determine the street axes while minimizing the density of connections relative to a direct system, and the detour to a system of minimal paths.

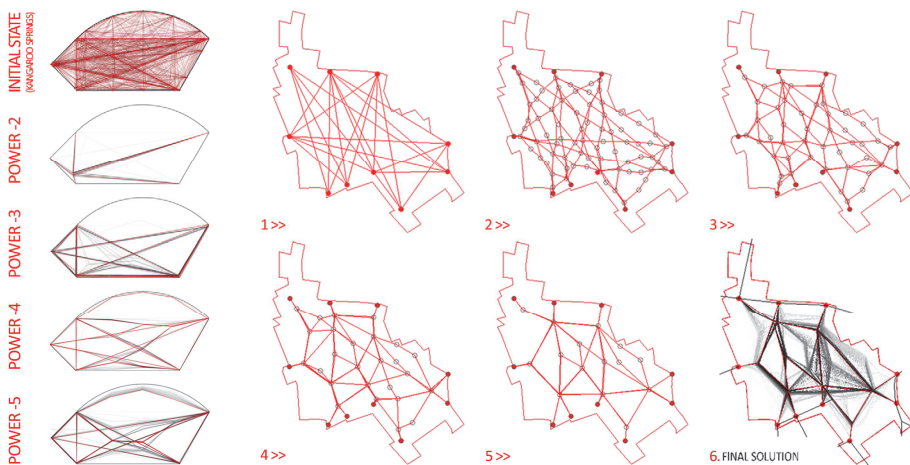

Figure 2. Pattern 1. Connect: minimized detour paths. Abstract experiments and case study.

3.2. PATTERN 2. CONNECT: MINIMAL PATHS

The second pattern determines the shortest path between a random set of points, simulating the soap film experiments outcomes. There are geometric constructions only for the cases of 3 and 4 points. For a higher number, determining the minimal path (or minimal Euclidean Steiner tree) is an *nP-hard* computing problem, only soluble using very sophisticated optimisation algorithms. We explored three digital methods: dynamic method (i.e. self-generation using Kangaroo's *Bend force*); geometric method (i.e. parameterization of the geometric construction) and algorithmic method (i.e. the use of FindSteinerTree branch-and-bound optimization algorithm). The latter was developed as the only one capable of calculating a number of points greater than 4. Thus, a Grasshopper script was created to find, together with FindSteinerTree, the optimal solution for a set of points randomly distributed in a space of a given dimension (Figure 3). The proposed method involved three steps:

- Exporting the points coordinates to a txt file (csv data format) via a Grasshopper script.
- Introducing the listed points in FindSteinerTree which, after calculation, saves the results in a new txt file, listing the new Steiner points and the links between vertices pairs of the new set of initial and Steiner points.
- Importing of this information in Grasshopper to draw automatically the tree. Rhino and Grasshopper may be seen as the GUI that FindSteinerTree lacks.

In this way it is possible to create an urban axis structure connecting places by following the minimal length. As a tree, it does not produce an urban network by itself, but it may be useful to think about the infrastructure distribution from the economic point of view. Different urban networks can be generated by recursively applying this pattern at different scales.

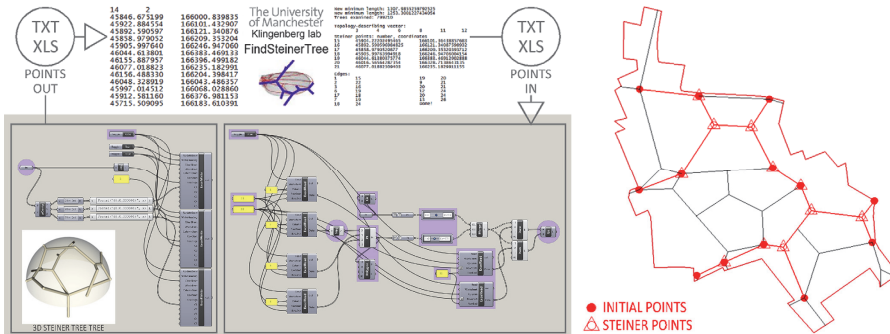

Figure 3. Pattern 2. Connect: minimal paths and minimal path network case study.

3.3. PATTERN 3. OCCUPY: FORCE OCCUPATIONS

The third pattern digitally simulated the magnetized needles and the bubble packing experiments, as well as their combination, through the use of Kangaroo (Figure 4). Initially, only the application of the positive value (i.e. repulsion) of the *PowerLaw* force component to a spring-particle system was investigated. The behaviour of a random distribution of points, seeds of *voronoi* territories, was dynamically simulated within a set of boundaries, with and without obstacles, representing the number of occupants and general areas of a typical block. It was observed an increasing regularity of the particle distribution as a function of its increasing number and force exponent (higher neighbourhood effect), and the disruptive effect of barriers. Later, during the practical application, this pattern was extended to include attractive and simultaneously attractive-repulsive interactions between particles and also between them and the block boundaries. The simulations produced a multitude of occupations which depend, among other factors, on the random initial arrangement of the particles. Although buildings shape was not an issue, the algorithm determines a minimum clearance distance between particles, enabling the automatic deployment of rectangular masses (9x13m, 1, 2 or 3 floors). This volumetries are set according to the proximity to other buildings and the relative orientation to the street reacts to the best solar exposure. This pattern thus allows defining the possible locations of an occupancy driven by the maximization, or minimization, of the distance to the neighbours, and the desired relationship with the boundaries of the block and its notable points (e.g. streets intersections), ensuring maximum sun exposure.

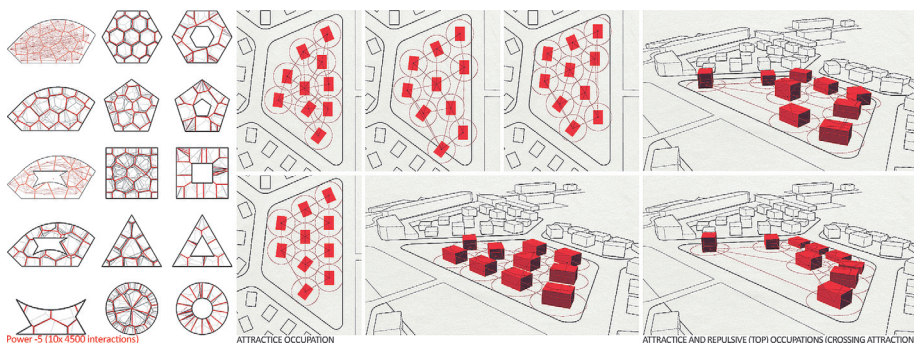

Figure 4. Pattern 3. Repulsion/attraction force occupations. Experiments and case study.

4. Experiment: applying the parametric urban patterns to the site

The selected site for the speculative experimental case studies is located on the west side of Porto (Portugal). It is a *terrain vague*, surrounded by two

urban morphologies: a regular one at west and another non-planned at east, corresponding to different periods of urbanization. This place seemed suitable to apply the studied Connect patterns as the anchor points were obvious (e.g. incomplete alleys, streets and intersections). To formalize the experiments, some simplifying initial assumptions were taken into account:

- The abstraction of topographical constraints – the site was considered flat.
- Only the existing local conditions were considered. Still, it was recognized the need for a north-south connection (reinforced when applying Pattern 1), and the location of a public space in the south, where some urban facilities are currently located and a future underground Metro station is scheduled.
- The issue of land use was only indicated by the location and volumetric features of the proposed masses; other urban features like lot subdivision and local accesses within the blocks were not studied.
- Buildings height and roads sections were maintained in accordance with the surroundings in order to evaluate the integration capacity of the proposals.

The workflow includes the following steps:

- Site analysis, determination of the points to connect and the environmental and patrimonial values to maintain (river, tanks, arboreal masses).
- Application of Pattern 1 or 2 to determine the axes of the streets.
- Determination of the street network hierarchy by an empirical evaluation of the axes continuity. Assignment of street sections according to their ranking.
- Definition of subareas/blocks to occupy or leave free (public space or park).
- Top-down occupation along the main street and the empty block to the south, with compact volumes representing service and mixed commercial functions.
- Application of Pattern 3 to the other subareas, resulting in informal settlements. The number of occupants is given by dividing the total area by the mean value of the surrounding urban lots area.
- Outline of the watercourse and arboreal masses defined through a parametric definition that produces a random distribution.

This workflow resulted in two proposals for the site (Figures 5-6), product of a mixed top-down and bottom-up approach. The first can be recognized in the initial action of conscious choice of the connecting points and the deployment of denser built occupation around the main public spaces. The second can be perceived in the determination of the streets axes or the locations and orientation of the dispersed buildings. Ultimately, it is the intermediate processes that are emergent. The transference of the computationally generated patterns to the configuration of the street networks and occupations is very literal and the urban parameters in use are limited, which leaves room for criticism; nonetheless our main concern was research-based

and consisted in the street network generation and the algorithmic processes that control occupation, and not the achievement of a complete urban design.

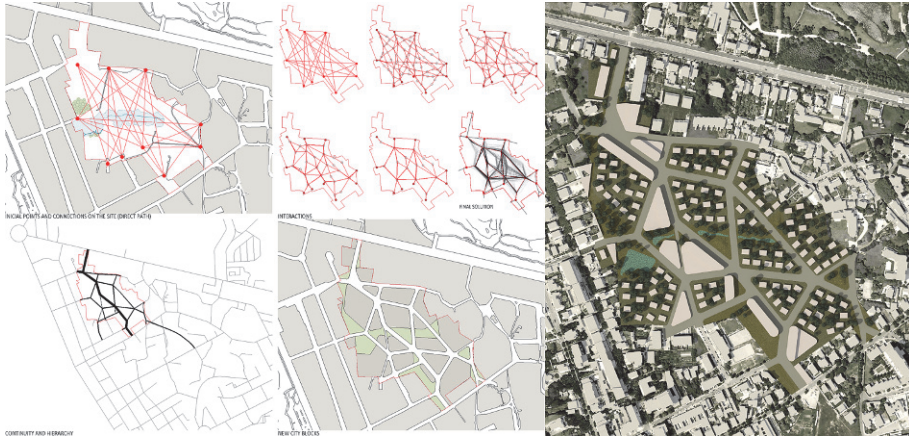

Figure 5. Proposal: minimized detour paths (Pattern 1 and 3). Process and final plan.

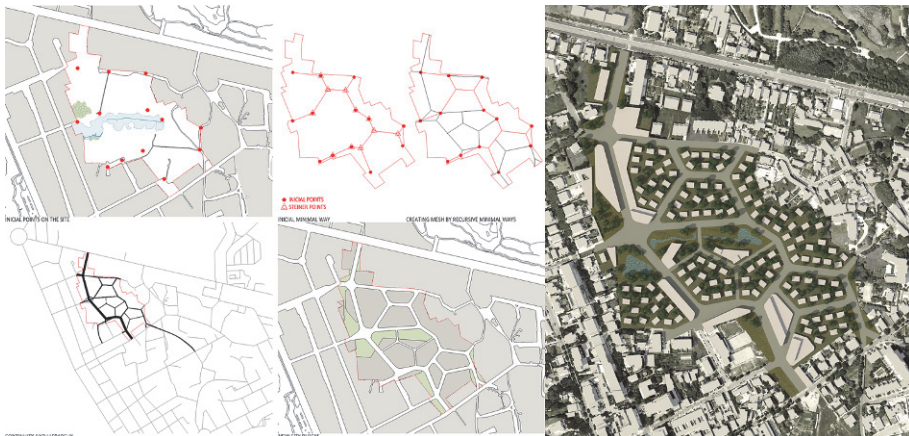

Figure 6. Proposal: minimal paths (Pattern 2 and 3). Process and final plan.

5. Conclusion and future work

The results obtained by the digital simulations are consistent with the experimental models made in IL. Despite the need for higher control over the processes, it was possible to incorporate the developed algorithms in a parametric urban design workflow. Referring to their applicability to design, the research developed so far on self-generated urban structures, suggests that these parametric patterns inspired in nature are extremely sensitive to initial and frontier conditions. Coupled with its interactivity, we believe that this

approach can be a benefit in projects that aim to sew or regenerate urban fabrics since it allows designing in a more reactive way in *Cartesian* planned discarded spaces. As Otto shows, these processes can be valuable to encode in the design the symbiosis with the natural and emergent processes occurring behind the scenes in any act of occupation of the surface of our planet. Moreover, it is possible to argue that the urban project is moving from the originality of form to the process one, from the unique proposal to the family of solutions, from the static design to the evolving pattern.

This research work also points out the need for a more seamless parametric integration of the various developed patterns in an uninterrupted workflow, the topological characterization of the proposed networks configurations, the account for topography and more compact urban morphologies. In this sense, the challenges for future work encompass studies to expand the parametric models incorporating a greater number of urban morphological, physical, environmental and legal features. For the assessment of the proposals validity, it is important to invest in analysis and reporting tools, such as spatial and behavioural analysis, the possibility to include public participation, and the potential use of V.R. models in a CAVE type environment.

6. References

- Alexander, C., Ishikawa, S., e Silverstein, M.: 1980, *A Pattern Language, Un Lenguaje De Patronos: Ciudades, Edificios, Construcciones*, Gustavo Gili, Barcelona.
- Batty, M.: 2005, *Cities and Complexity: Understanding Cities with Cellular Automata, Agent-based Models, and Fractals*, MA: MIT, Cambridge.
- Coates, P. S.: 2010, *Programming Architecture*, Routledge, Abingdon.
- Frick U., Grabner T.: 2012, "Urban field - adaptive urban fabric". Available from: Open Source Repository <<http://www.suckerpunchdaily.com/>> (accessed 8 September 2013).
- Georgiadou, E.: 2012, Ants, Bundles and Territories, (September), 1–81. Available from: Open Source Repository <<http://www.mscaac.org/>> (accessed 20 September 2013).
- Otto, F.: 2011, *Occupying and connecting: thoughts on territories and spheres of influence with particular reference to human settlement*, Edition Axel Menges, Stuttgart.
- Otto, F.: 1971, Minimal nets, in B. Burkhardt (ed.), *ILL: Minimal nets*, Karl Krämer Verlag Und IL, Stuttgart, 4-7.
- Schaur, E. (ed.): 1992, *IL39: non-planned settlements: characteristic features - path system, surface subdivision*, Institut für leichte Flächentragwerke, Universität Stuttgart, Stuttgart.
- Schumacher P.: 2008, Parametricism - A New Global Style for Architecture and Urban Design, in N. Leach (ed.), *AD Architectural Design - Digital Cities*, 79 (4), 14-23.
- Silva, R.C., Amorim, L.M.E.: 2010, Parametric urbanism: emergence, limits and perspectives. Available from: <www.nomads.usp.br/virus/virus03/> (accessed 15 August 2013).
- Steinø, N.: 2010, Parametric Thinking in Urban Design. Available from: Open Source Repository <<http://cumincad.architecturez.net/>> (accessed 8 September 2013).
- Stolk, E.: 2009, *Model town: using urban simulation in new town planning*, Sun, Amsterdam.
- Trummer, P.: 2008, Engineering Ecologies, in M. Hensel and A. Menges (eds.), *Architectural Design Special issue: Versatility and Vicissitude*, 78 (2), 96-101.
- "Klingenberg lab, FindSteinerTree": 2006(?). Available from: Open Source Repository <<http://www.flywings.org.uk/FindSteinerTree/>> (accessed 30 May 2013).
- Woodbury, R.: 2010, *Elements of Parametric Design*, Routledge, New York.