

OEIRAS

ESPAÇO NATURAL, INFRAESTRUTURAS E ESPAÇO PÚBLICO

PROGRAMA DE HABITAÇÃO



VIAS FERROVIÁRIAS - - - - -
VIAS RODOVIÁRIAS ————



0 5 Km

TERCENA | Registo fotográfico



TERCENA | Evolução Urbana

1947

1965

1987

2000

2020



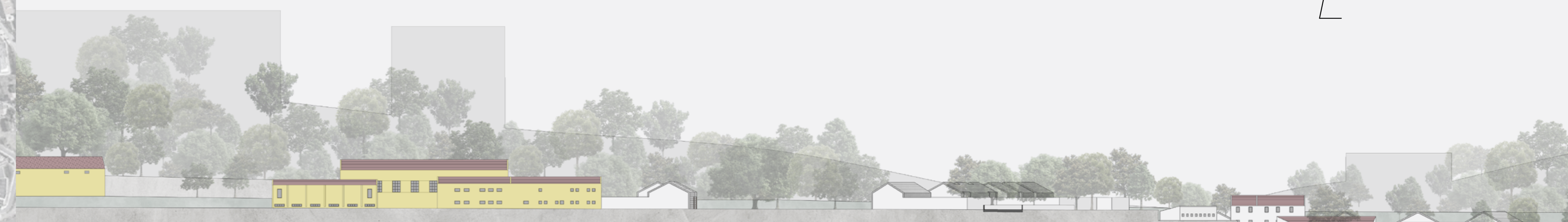
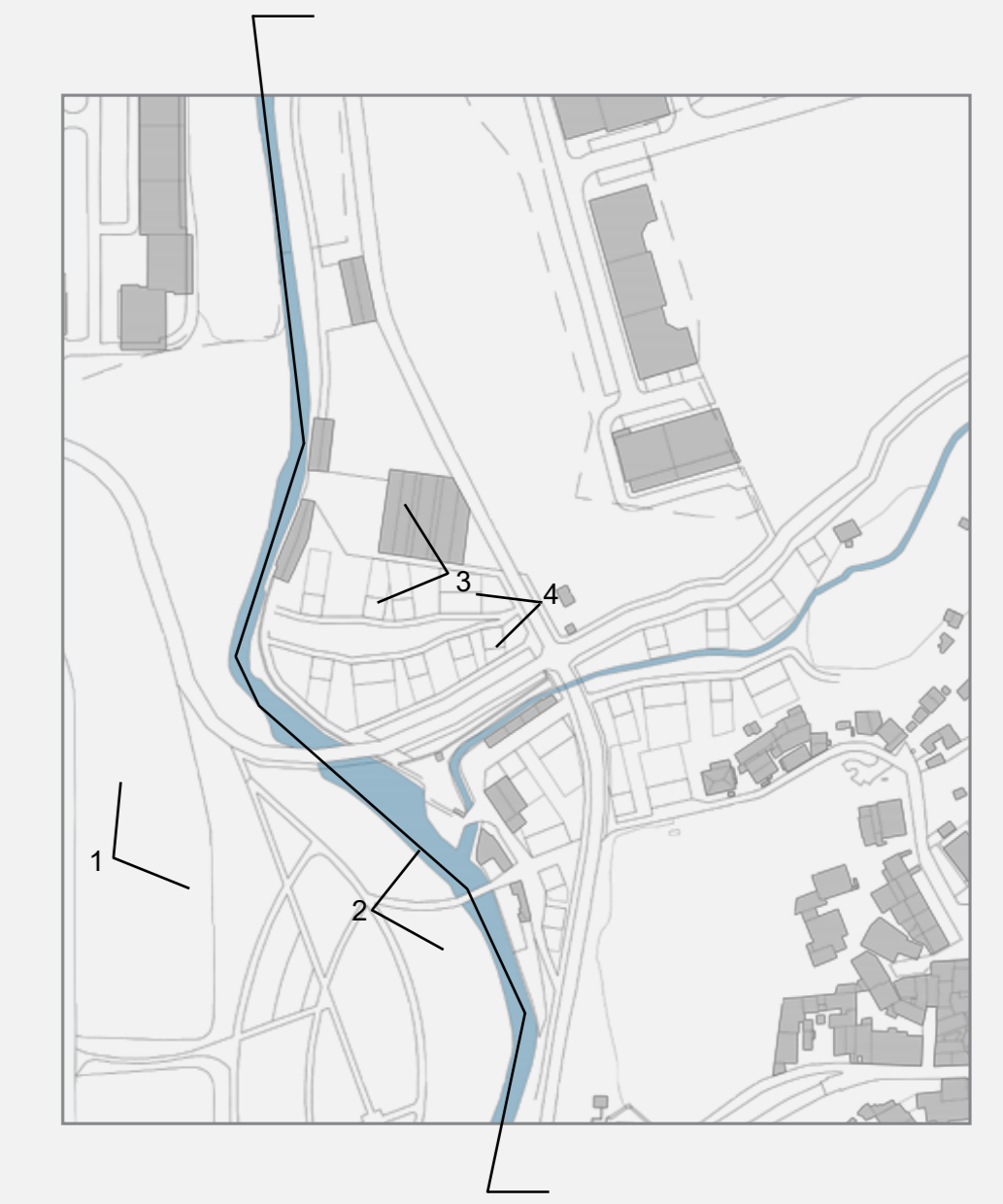

Plano geral:
 Ribeira de Barcarena
 Estrada do Cacém

Locais de Implantação:
 Acessos Rodoviários:
 Existente
 Proposto

Acessos Pedonais:
 Existente
 Proposto

Linha urbana proposta
 Edifícios não demolidos

Acessos Rodoviários existentes
 Acessos Rodoviários Propostos
 Acessos Pedonais Existente
 Acessos Pedonais Propostos
 Linha urbana proposta
 Edifícios não demolidos



- 1 - Espaço de ginásio com zona de refeições; 1A - Zona de desporto exterior
- 2 - Mercado; 2A - Espaço de cargas e descargas
- 3 - Espaço de co-working
- 4 - Tipologia T0/T1
- 5 - Tipologia T4
- 6 - Pátios das tipologias

- A - Pavimento tijolo
- B - Pavimento calçada portuguesa
- C - Pavimento de calçada de basalto
- D - Estacionamento de veículos
- E - Estrada de asfalto
- F - Ribeira de Barcarena

0 20 m 50 m

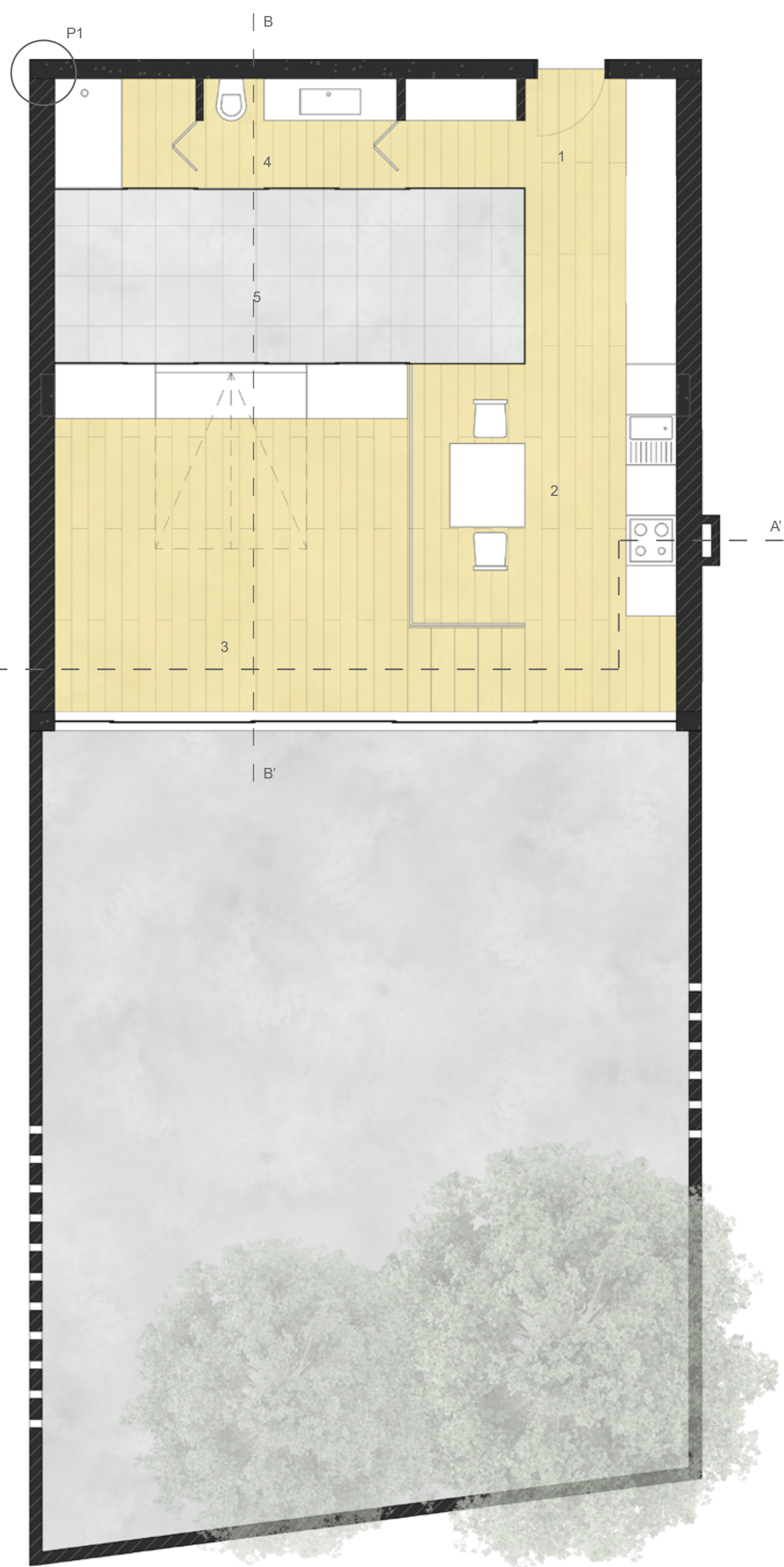

1- Entrada e zona de armazenamento: 7,8m²
 2- Cozinha: 13,2m²
 3- Sala/Quarto: 17,4m²
 4- W.C.: 5,4m²
 5- Pátio Interior: 11,6m²
 Área bruta de habitação: 52,1m²
 Planta T0/T1 | 1:50

Estudos T0/T1



Estudos T4

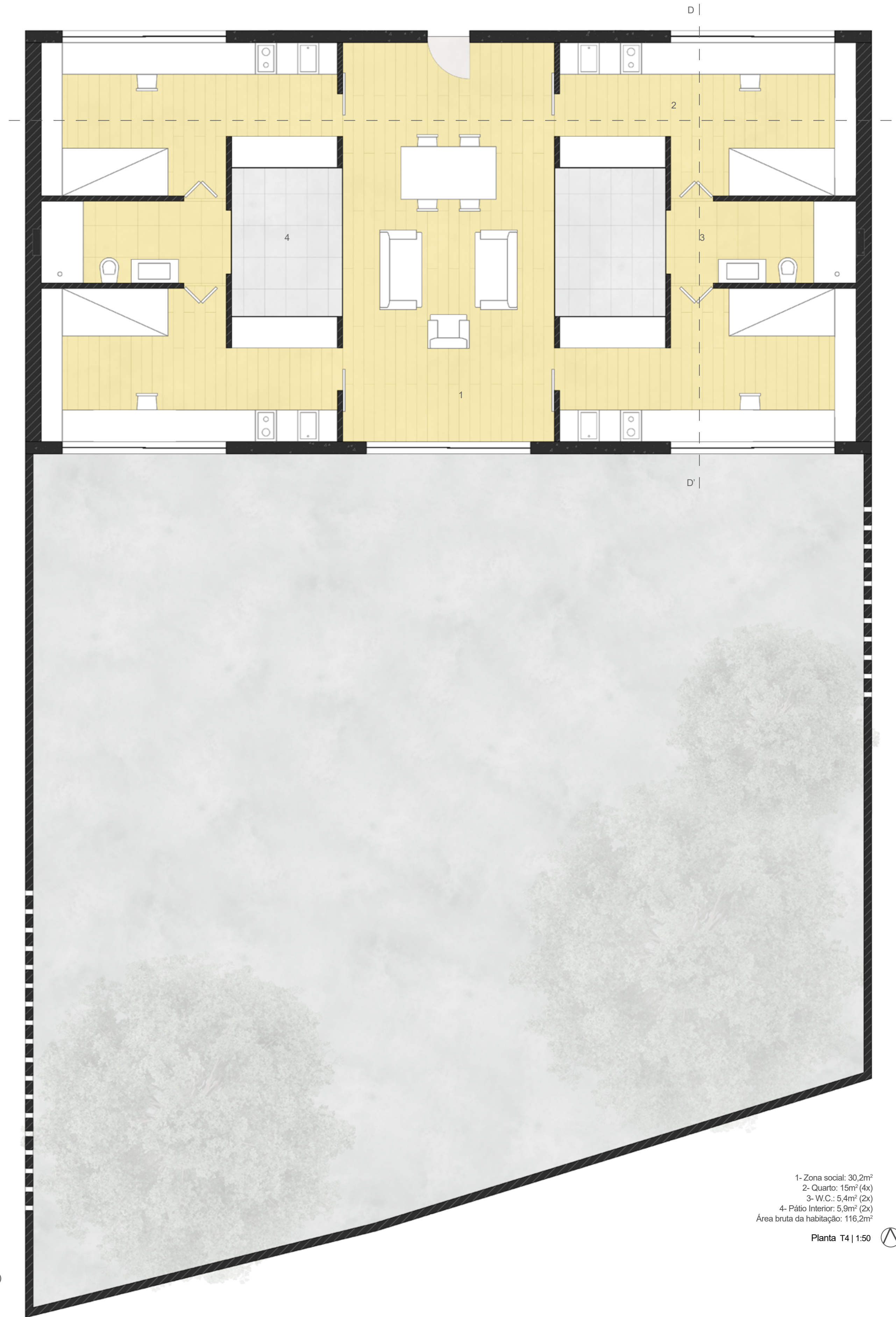
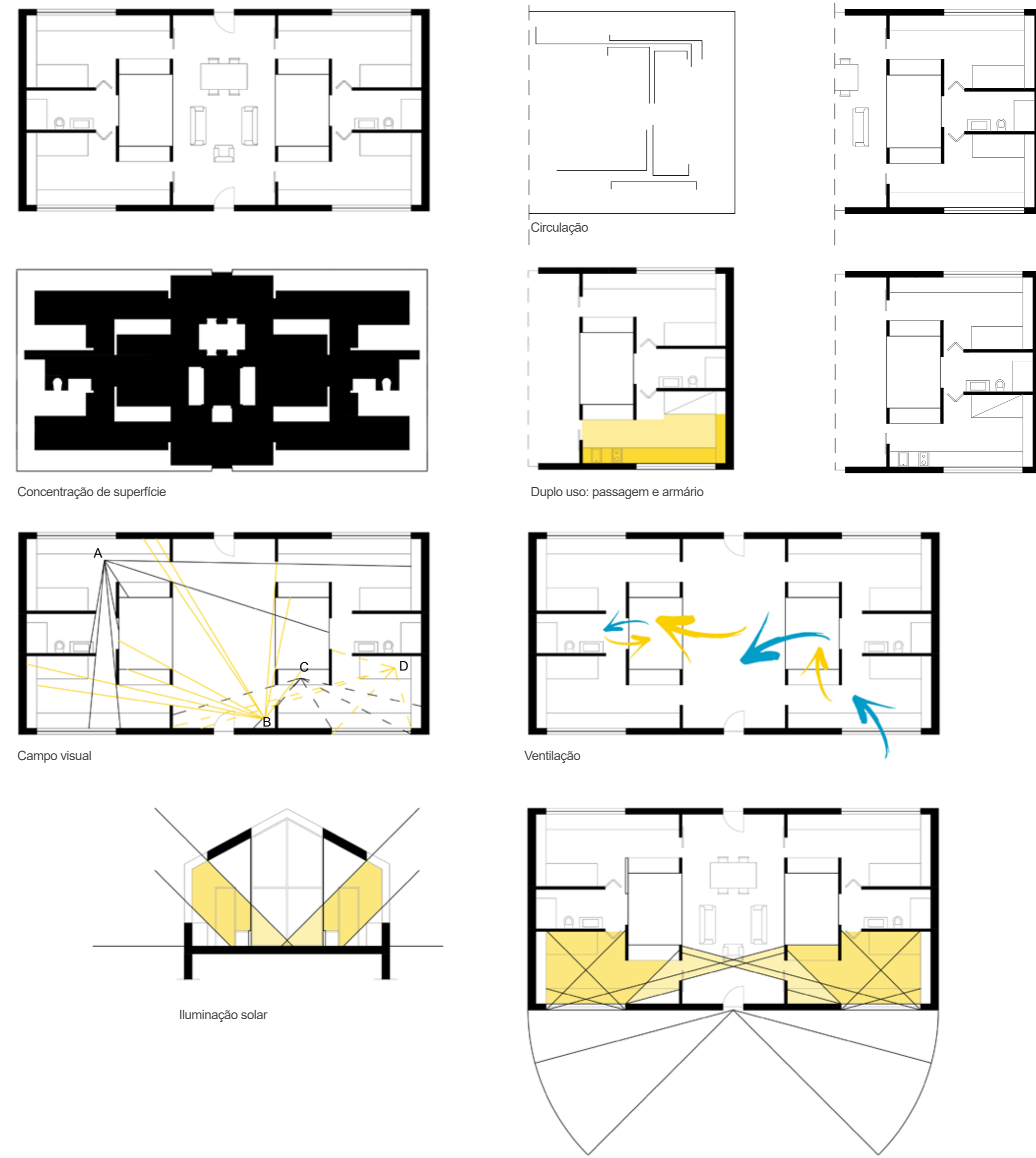

1- Zona social: 30,2m²
 2- Quarto: 15m² (4x)
 3- W.C.: 5,4m² (2x)
 4- Pátio Interior: 5,9m² (2x)
 Área bruta de habitação: 116,2m²
 Planta T4 | 1:50



T0/T1 | Opção A | Versão dia
 T0/T1 | Opção A | Versão noite
 T0/T1 | Opção B | Versão dia
 T0/T1 | Opção B | Versão noite

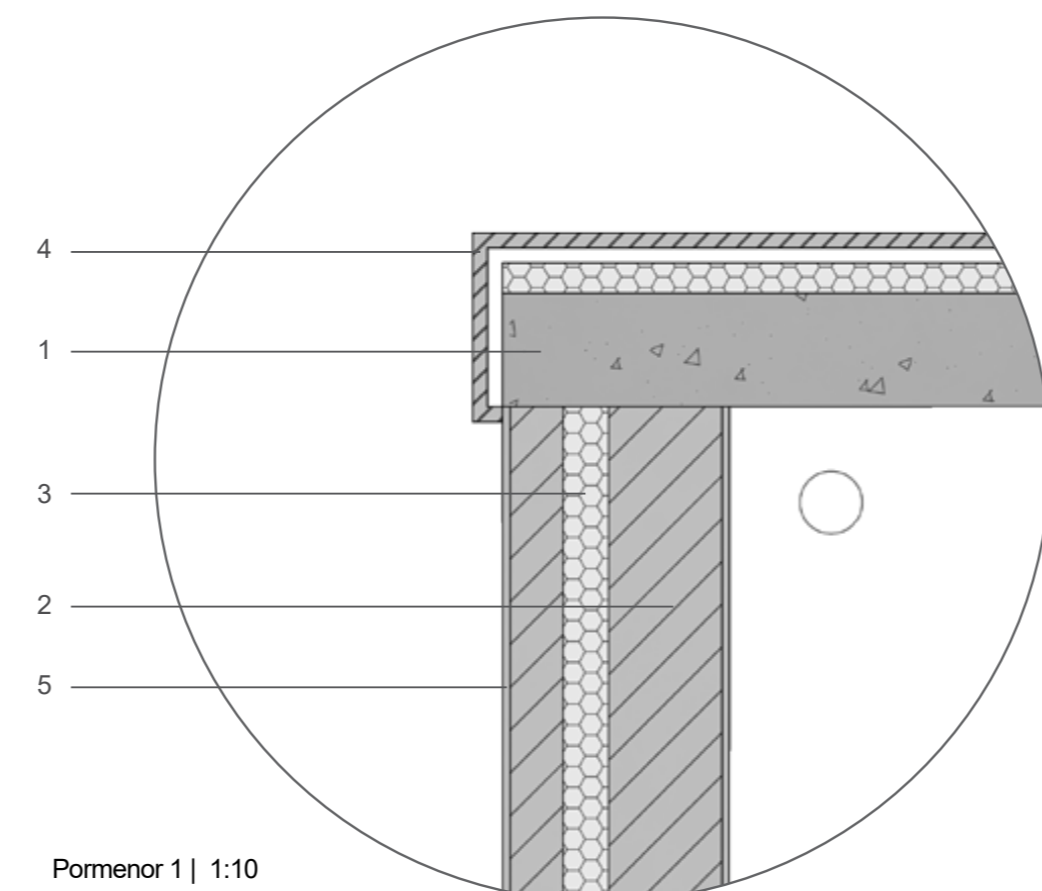

Pormenor 1 | 1:10

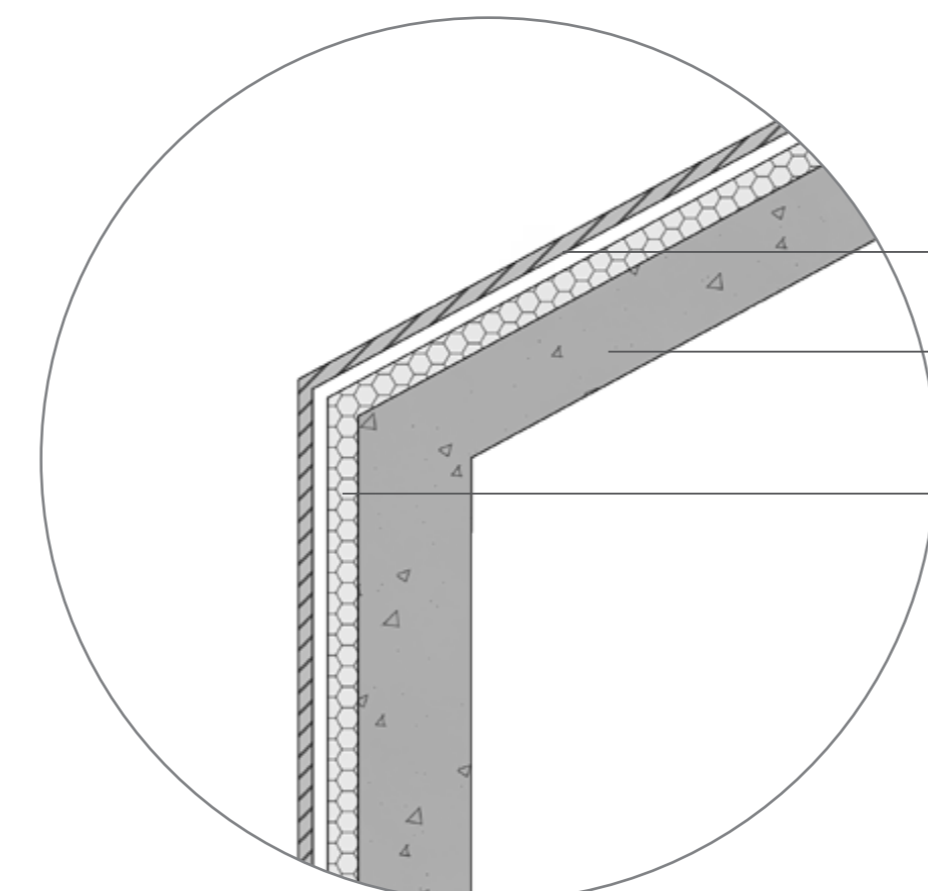

1- Betão armado
 Parede: malha singular
 Cobertura: malha dupla
 2- Alvenaria de tijolo
 3- Isolamento térmico
 4- Placas de Revestimento de calcário (cinza)
 com apliques metálicos
 5- Reboco
 Pormenor 2 | 1:10



Corte AA

Corte BB

Corte CC

Corte DD



T0 | Opção A



T0 | Opção B



T4 | Espaço Individual



T4 | Espaço Social