

## Repositório ISCTE-IUL

---

Deposited in *Repositório ISCTE-IUL*:

2018-07-17

Deposited version:

Post-print

Peer-review status of attached file:

Peer-reviewed

Citation for published item:

Souza, R., Roza, V. C. C. & Postolache, O. (2017). A multi-sensing physical therapy assessment for children with cerebral palsy. In 11th International Conference on Sensing Technology, ICST 2017. Sydney: IEEE.

Further information on publisher's website:

10.1109/ICSensT.2017.8304513

Publisher's copyright statement:

This is the peer reviewed version of the following article: Souza, R., Roza, V. C. C. & Postolache, O. (2017). A multi-sensing physical therapy assessment for children with cerebral palsy. In 11th International Conference on Sensing Technology, ICST 2017. Sydney: IEEE., which has been published in final form at <https://dx.doi.org/10.1109/ICSensT.2017.8304513>. This article may be used for non-commercial purposes in accordance with the Publisher's Terms and Conditions for self-archiving.

---

### Use policy

Creative Commons CC BY 4.0

The full-text may be used and/or reproduced, and given to third parties in any format or medium, without prior permission or charge, for personal research or study, educational, or not-for-profit purposes provided that:

- a full bibliographic reference is made to the original source
- a link is made to the metadata record in the Repository
- the full-text is not changed in any way

The full-text must not be sold in any format or medium without the formal permission of the copyright holders.

---

# A Multi-sensing Physical Therapy Assessment for Children with Cerebral Palsy

Regina de Souza

Instituto Universitário de Lisboa, ISCTE-IUL  
Instituto de Telecomunicações, IT-IUL  
regina\_souza@iscte.pt

Válber César C. Roza

Instituto Universitário de Lisboa, ISCTE-IUL  
IT-IUL&UFRN  
valber\_cesar\_roza@iscte-iul.pt

Octavian Adrian Postolache

Instituto Universitário de Lisboa, ISCTE-IUL  
Instituto de Telecomunicações, IT-IUL  
opostolache@lx.it.pt

**Abstract** — This work presents the development of a multi-sensing interface called Palsy Thera Sense, to provide information data obtained during physical therapy of the children with cerebral palsy. It allows the monitoring the children's motor skills, and provide metrics that can be later used for proper and effective training. This interface is based on distributed force measurement system characterized by two different load cells. The signals from signals from the load cells distributed on the level of a force platform and at the level of child's body support ropes that are tied on the cerebral palsy spider cage are acquired and wireless transmitted to a client computation platform. Thus different tests can be carried out including, gait simulation or it can be study of children balance during different activities such as serious game playing for upper limb rehabilitation. The interface shown to be an important tool that provide support to cerebral palsy rehabilitation process, and for objective evaluation of the patients during the rehabilitation period. Several experimental results are included in the paper highlighting the capabilities of the designed and implemented.

**Keywords** – Cerebral palsy; rehabilitation; assistive technology; signal analysis; multi-sensing devices.

## I. INTRODUCTION

Physical medicine and rehabilitation (PM&R), also known as physiatry or rehabilitation medicine, aims to enhance and restore the functional ability and quality of life to those with physical impairments or disabilities affecting the brain, spinal cord, nerves, bones, joints, ligaments, muscles, and tendons [1]. Subjective and objective evaluations that are current used by physiotherapist provide information about rehabilitation process. The usage of scale physical rehabilitation outcome is a current method to extract information about motor capability of the patient under physical rehabilitation, however is highly affected by subjective elements that conduct to less accurate evaluation results. Nowadays, to increase the accuracy of the motor condition progress of the patients under physical rehabilitation, the smart sensors and advanced signal processing are used [1-2], however, there are still a lack of implementation in the field of cerebral palsy rehabilitation monitoring and physical rehabilitation outcome.

Cerebral palsy is a term generalized from the chronic non-progressive encephalopathy. It consists of a group of changes in the development of motor functions, resulting from a static lesion in the central nervous system [3]. This injury can occurs due to several factors during periods of prenatal, natal and neonatal [4-5]. The incidence of this pathology is very high, being the most common disorder in child development [6].

The most common types of cerebral palsy are: spastic, dyskinesia, ataxia and Mixed forms (most often spasticity and ataxia, athetosis, less often and athetosis) [7]. As solution to improve physical condition of this type of children, physical therapy allows to stimulate the patient's motor development, allowing their brain to "learn" the movements performed during the sessions that can be appropriate monitored using smart sensing systems [reference].

Several multi-sensing solutions that are designed to give support to stimulation of motion and to provide the balance aid during the gait rehabilitation process, are reported in literature [8-12], however are less or not reported systems for cerebral palsy monitoring. Several metrics can be mentioned as a sensing systems associated with the postural analysis of the body and its static and dynamic balance such as, center of pressure position and trajectory pressure that were considered in different practical approaches [13-15].

In this context the work presents the development of a multi-sensing interface called Palsy Thera Sense, to give support to the physical rehabilitation for children with cerebral palsy, allowing the monitoring of static and dynamic behavior and providing accurate information about the motor skills, and to evaluate the physical rehabilitation plan effectiveness.

This paper is organized such as: Section II presents the Palsy Thera Sense description, including the hardware and software; Section III, presents the results analysis, as such as the tests executed with all developed platforms and its output signals; Section IV presents the conclusions and future works and the acknowledgements presented in Section V.

## II. MULTI-SENSING FRAMEWORK DESCRIPTION

This work presents a multi-sensing interface called Palsy Thera Sense. It is a rehabilitation system composed of two platforms that includes two types of force sensors (i.e. load cells) to monitor the forces applied by a patient with cerebral palsy while he performs the gait rehabilitation under physiotherapist's supervision.

It is represented by a wireless sensor network including node with multiple force measurement channels that support the physical training monitoring for children with cerebral palsy. The signals obtained for different performed tasks such as, gait task and body equilibrium (or body balance during serious game performing) are transmitted to the wireless sensor coordinator associated with the client computation platform characterized by wireless connectivity.

## A. Hardware Description

For gait training support task, a force platform characterized by four load cells and signal acquisition and wireless communication modules (AWCM) is considered.

Some constructive elements are: a double transparent acrylic boards that are used for the force platform mechanical structure, four force sensors ( $FS_i$ ) connected to AWCM that is characterized by ZigBee transceiver (XBee P1) and a battery as shown in Fig. 1.

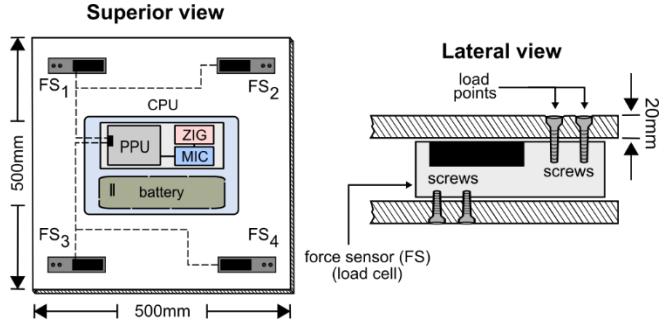

Fig. 1. View of the AWCM and its embedded devices i.e., a central processing unit (CPU) that includes a pre-processing unit (PPU), a microcontroller (MIC) and a ZigBee transceiver (ZIG).

Each load cell was powered using a 10.8V Li-ion battery with a capacity of 5200mAh, allowing great autonomy of the system; it has the load capacity of 1-100kg and operates with a tension of excitation of 10-15V. Its analog output is applied to the amplification and filtering scheme based on INA 122 instrumentation amplifier and low pass analog filter based on LM324. The analog processed signals on the level of PPU are applied to A0-A3 analog inputs of the Arduino Uno embedded processing and the communication board characterized by a ZigBee Shield module, that it is characterized by an XBeeShield module.

To give support to the body equilibrium of the people with cerebral palsy, was developed four rope body support including the axial load cells or rope sensors ( $RS_i$ ) described in Fig. 2.

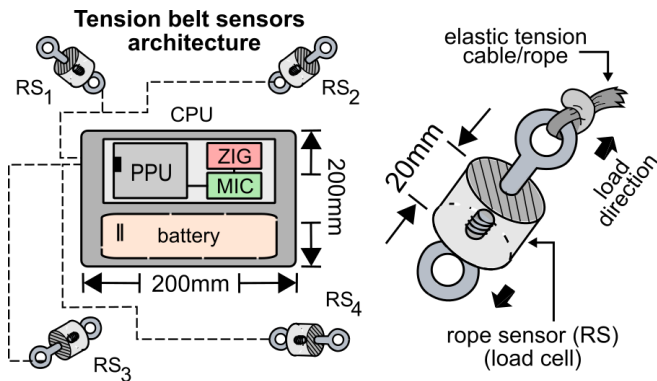

Fig. 2. Rope and tension belt architecture.

The analog signals delivered by the load cells were amplified using a 4 channels amplification modules based on INA122 instrumentation amplifier, which the gain was calculated by Equation 1,

$$G = 5 + \frac{200k\Omega}{R_G} \quad (1)$$

where  $R_{GAIN}$  is the resistance associated with the instrumentation amplifier, and has the fixed value of 1.2k $\Omega$  as shown in Fig. 3.

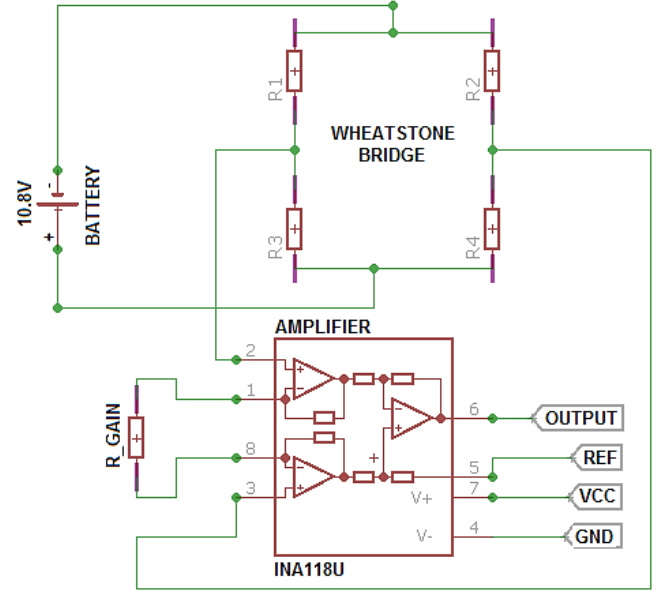

Fig. 3. Acquisition and pre-amplification circuit used for one load sensor from the force platform and tension belt system.

Considering the value of the power supply  $V_{supply} = 10.8V$ , the gain  $G = 172$  and the sensitivity of the sensor  $S = 2mV/V$ , then, the maximum value in volts (V) of each output signal  $V_{F_i}$  is given by Equation 2, where  $F_i$  represent the forces applied under the platform.

$$V_{F_i} = V_{supply} \cdot S \cdot G = 3.71V \quad (2)$$

These output signals  $V_{F_i}$  associated with the force measurement channels are acquired using the ADC of the Arduino Uno that converts these outputs in force values based on embedded software implemented on the microcontroller.

The center of pressure/force is also considered in this work and is based on the forces values ( $F_i$ ) and the geometry of the force platform, although, this measurement is part of the software task and is presented later.

## B. Communication Architecture

The system communication is characterized by an XBeeShield module that performs the wireless ZigBee network to determines a set of specifications for wireless

communication between electronic devices, showing a low power, low data transmission rate and latency and low cost of implementation. This technology requires less consumption, by having a smaller range (about 100 meters) and all network nodes may transmit or retransmit data successively until it reaches the final destination [16]. It is based on the OSI model and is substantiated by the IEEE 802.15.4, following the trust center concept (which is under the central node of the network, called the coordinator) [17-19].

We used two XBee modules S2 and one XBee module S2-PRO, which correspond to the communication modules of the platform and the tension belt, and the coordinator of the network, respectively.

The coordinator node is connected to the computer through USB connection and this is responsible for: authentication of each network devices, distribution and maintenance of the message's security. The values received on the coordinator are decoded in MATLAB, which generates analysis charts.

The communication system's topology is based on star network, including a coordinator node (central) and two end-nodes that send the data obtained from measurement level and embedded processed to the coordinator as presented in Fig. 4.

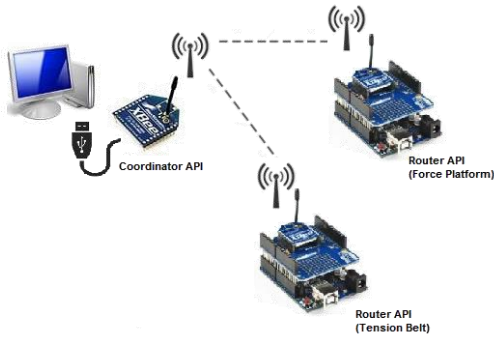

Fig. 4. Distributed force measurement system architecture including the tension belt end-node and force platform.

### C. Software Description and Sensors Measurements

Two software components were developed such as: a software for wireless communication based on the sensor network and another for the signal acquisition, processing and additional calculations.

The wireless communication software is used with the force platform and the tension belt sensors, sending the sensor values through the wireless network. The software for signal treatment is based on MATLAB and C programming under the Arduino IDE, to execute the signal acquisition, signal conditioning, center of mass calculation, metrics associated with gait assessment, and the communication between the sensors nodes and the coordinator node.

This work also considers the center of mass/force measurements to inform the force distribution of each person under the platform as defined by Equations 3-4,

$$X_{FP} = \frac{\sum_{i=1}^4 F_i x_i}{\sum_{j=1}^4 F_j} \quad (3)$$

$$Y_{FP} = \frac{\sum_{i=1}^4 F_i y_i}{\sum_{j=1}^4 F_j} \quad (4)$$

where  $F_1, \dots, F_4$  represent the analog outputs (i.e. force values) from each load sensor, and the FP( $X_{FP}, Y_{FP}$ ) represents the resultant force point as shown in Fig. 5.

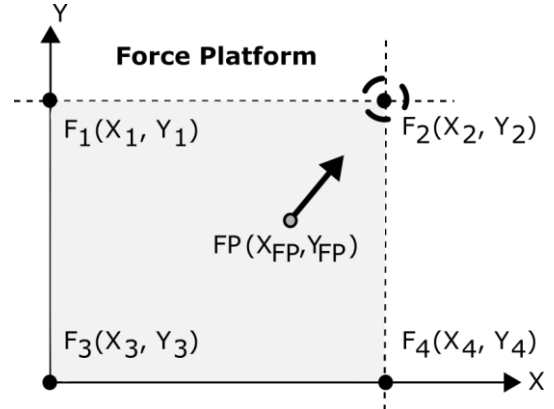

Fig. 5. Force distribution under the platform.

## III. RESULTS AND DISCUSSIONS

The present work develops a multi-sensing interface to give support on the analysis of gait evolution in time of patients with cerebral palsy called Palsy Thera Sense. It is composed of two platforms that includes two types of force sensors (i.e. load cells).

Furthermore, different patterns of gait behavior simulation were applied using the platforms as for instance: gait behavior simulation of a patient without cerebral palsy (i.e. normal gait) and gait behavior simulation of a patient with cerebral palsy.

### A. Sensors Baselines Measurements

A baseline signal for each sensor was obtained to be used as a blank signal to be subtracted from corresponding outputs values. The force sensors  $FS_1$  and  $RS_1$  present baseline values ranging from 0 to 0.0049V; the sensors  $FS_2$  and  $RS_2$  present baseline values ranging from 0 to 0.0733V; the sensors  $FS_3$  and  $RS_3$  present a baseline values ranging from 0 to 0.2884V; and the sensors  $FS_4$  and  $RS_4$  presented a baseline values ranging from 0 to 0.2199V;

Fig. 6 shows the baselines signals for the force sensors associated with the force platform and the sensors associated with the rope for user body support, where this sensors are ranging from 0 to 0.2884V.

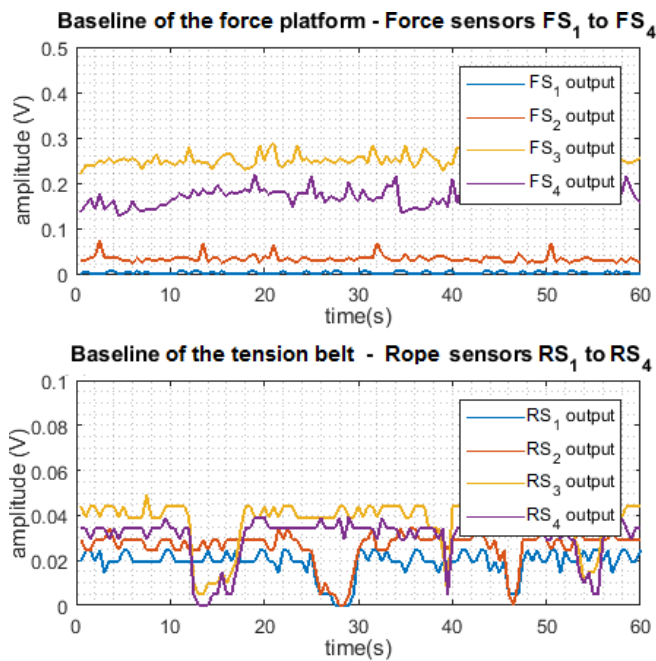

Fig.6. Acquired baselines voltage during 60s test period.

**B. Sensors Outputs with Fixed Load**

The platform was also tested using fixed load of 5kg. The outputs sensors decreased from the baseline, are shown in Fig. 7.

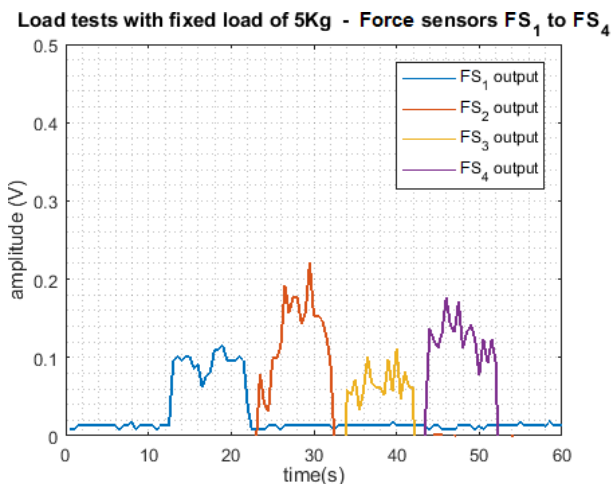

Fig 7. Output signals from fixed load tests.

**C. Sensors Outputs of Gait Simulations**

Fig. 8 shows the output signals delivered by the force platform during a normal gait simulations for 5 gait cycle, load of 67kg and time of 60 seconds.

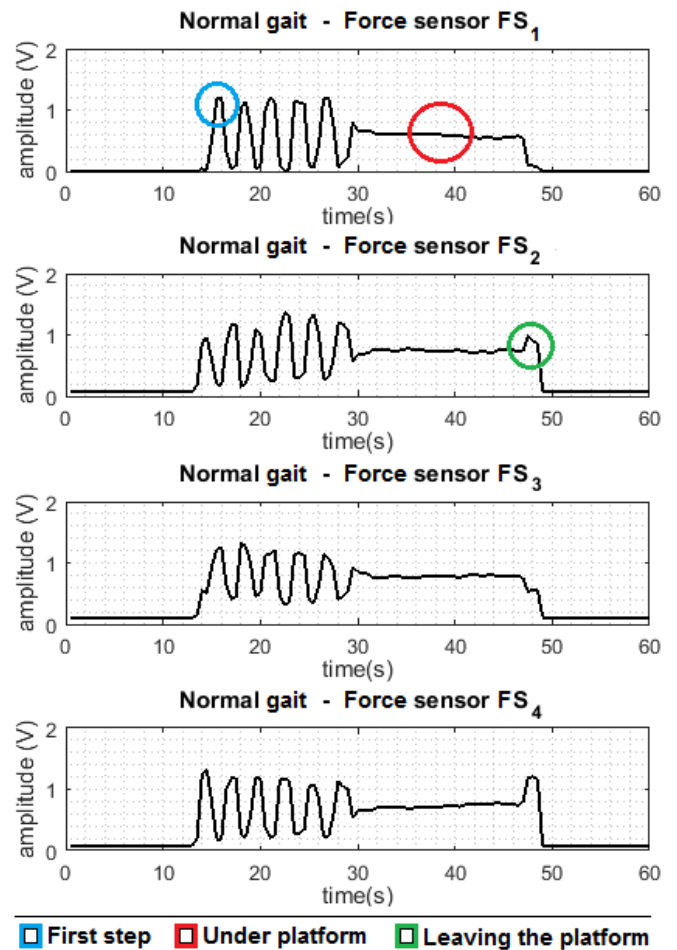

Fig 8. Output signals representing a normal gait considering a load of 67kg during 1 minute.

Fig. 9. shows a simulation of two different cerebral palsy gaits during 90s. With these gaits, are possible to note the different patterns between a normal gaits and an abnormal gaits presented by the force platform.

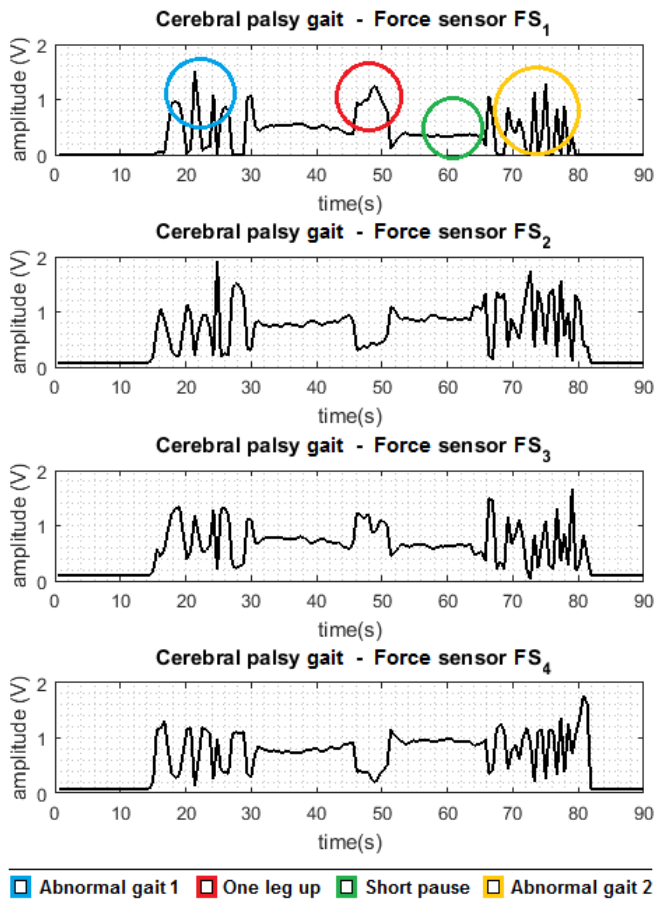

Fig. 9. Output signals representing a cerebral palsy gait during 90s.

#### D. Center of forces Measurements

The center of forces was also simulated to the force platform according to Equations 3-4.

Two trials were carried out, without weight under the surface of the platform and with a weight of approximately 50 kg, following a path in order to test all the main points of the platform (load cell points and center of the surface). The duration of the test was about 1 minute with a range of 0.5 seconds in the generation of packets.

The Figure 10 shows the movements of the center of force point, the baseline on the center of forces and the platform center. Observing the baseline point, it may note that the baseline presents a small deviation of the platform center, showing the platform calibration.

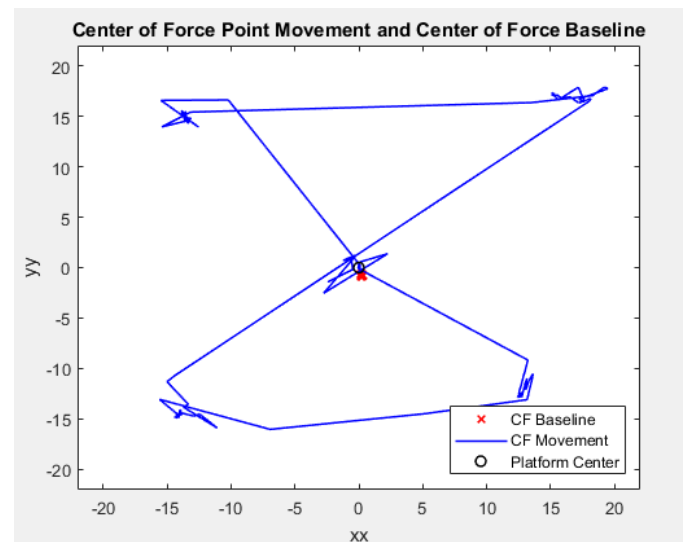

Fig. 10. Center of force measurements.

#### IV. CONCLUSIONS AND FUTURE WORKS

This work presented a force wireless sensor network associated with the monitoring of child with CP during the physical therapy. Some preliminary analysis of the simulations of several gaits and body balance during gait task are presented. A force distributed measurement system was designed and implemented; to be used for gait characterization for children with cerebral palsy.

The developed multi-sensing interface provides reliable information associated with different gait type and about the body balance.

As the future work, can be mentioned the usage of data acquired from the sensors as inputs for deep analysis and data mining in order to automatically identify or classify different patterns of user gait and user body balance.

#### V. ACKNOWLEDGMENT

This research is supported by Instituto de Telecomunicações (IT-IUL) at ISCTE-IUL, Lisbon, Portugal and Fundação para Ciência e Tecnologia (FCT) project PTDC/DTP-DES/6776/2014.

#### REFERENCES

- [1] O. Postolache, G. Postolache, Development and Selection of Balance Sensing Devices, *IEEE Instrumentation and Measurement Magazine*, Vol. 20, No. 1, pp. 38 - 48, February, 2017.
- [2] AAPM&R, "About Physical Medicine and Rehabilitation" on-line at <http://www.aapmr.org/about-physiatry/about-physical-medicine-rehabilitation>, August 2017.
- [3] Dimitrijević L, Jakubi B. THE IMPORTANCE OF EARLY DIAGNOSIS AND EARLY PHYSICAL TREATMENT OF CEREBRAL PALSY. *FACTA UNIVERSITATIS. Medicine and Biology* Vol.12, No 3, 2005.
- [4] Katherine, T; Ratliffe, M. A. *Paralisia Cerebral. Fisioterapia na Clínica Pediátrica: guia para equipe de fisioterapeutas*. São Paulo: Editora Santos, 2002.

- [5] KOK, F. As Principais Afecções em Neurologia Infantil – Encefalopatias Não-Progressivas: deficiência mental e paralisia cerebral. In: NITRINI, R; BACHESCHI, L. A. A Neurologia que Todo Médico Deve Saber. 2. ed. São Paulo: Atheneu, 2003.
- [6] Capute and Accardo's Neurodevelopmental Disabilities in Infancy and Childhood, Third Edition. Edited by Pasquale J. Accardo, MD. 2008, Paul H. Brookes Publishing Co, Baltimore, MD.
- [7] Majnemer A, Mazer B. New directions in the outcome evaluation of children with cerebral palsy. *Semin Pediatr Neurol* 2004.
- [8] González A, Hayashibe M, Dermican E, Fraisse P. Center of Mass Estimation for Rehabilitation in a Multi-contact Environment: a Simulation Study. *IEEE International Conference on Systems, Man, and Cybernetics*, 2013.
- [9] M. Mencattelli, E. Donati, M. Cultrone, C. Stefanini. Customized Load Cell for Three-Dimensional Force-Moment Measurements in Orthodontics. *5th IEEE RAS & EMBS International Conference on Biomedical Robotics and Biomechanics (BioRob)*. São Paulo, Brazil, 12-15, 2014.
- [10] Sanhueza G. Test system for clinical force platforms. *32nd Annual International Conference of the IEEE EMBS*. Buenos Aires, Argentina, 2010.
- [11] Kaplan J, Kelley M, Williams J, Gielo-Perczak K, Ph.D. Calibration Device for Quantifying Error in Force Plates. GP Musculoskeletal System Modeling Lab. Biomedical Engineering Department University of Connecticut; Storrs, CT 06269 USA.
- [12] Gu S, Jiang H. Research on Calibration Methods for Nonlinear Effects in Electromagnetic Force Equilibrium Sensor. *14th International Conference on Control, Automation and Systems (ICCAS 2014) in KINTEX*, Gyeonggi-do, Korea, 2014.
- [13] Boukhenous S, Attari M, Remram Y. FORCE PLATFORM FOR POSTURAL BALANCE ANALYSIS. *The 11th International Conference on Information Sciences, Signal Processing and their Applications: Main Tracks*.
- [14] Ong A, Gouwanda D. Investigating Postural Equilibrium of Individuals with Different Athletic Skill Levels. *IEEE Conference on Biomedical Engineering and Sciences*, Miri, Sarawak, Malaysia, 2014.
- [15] Sooksirimuch P, Soontomvipart K, Tangwongsan C. Development of A Force Platform System for Standing and Walking Analysis of Canines. *Biomedical Engineering International Conference (BMEiCON-2015)*, Thailand, 2015.
- [16] <http://standards.ieee.org/about/get/802/802.15.html>
- [17] FRENZEL L. What's The Difference Between IEEE 802.15.4 And ZigBee Wireless? <http://www.electronicdesign.com/what-s-difference-between/what-s-difference-between-ieee-802154-and-zigbee-wireless>.
- [18] Bielsa A, Gascón D. Triple Security in ZigBee: Link, Network and Application layer Encryptions. April 15th, 2010.
- [19] Gascón D. Security in 802.15.4 and ZigBee networks” April 28th, 2009.