

TESTING HIGH VOLATILITY EXPECTATION TRADES
ON MACROECONOMIC AND POLITICAL EVENTS OF
2016

Catarina da Silva Ferro Costa Pereira

Dissertation submitted as partial requirement for the conferral of
Master in Business Administration

Supervisor:
Prof. Doutor José Carlos Dias, Prof. Associado (com Agregação), ISCTE Business
School, Finance Department

October 2017

TESTING HIGH VOLATILITY EXPECTATION TRADES
ON MACROECONOMIC AND POLITICAL EVENTS OF
2016

Catarina da Silva Ferro Costa Pereira

Dissertation submitted as partial requirement for the conferral of
Master in Business Administration

Supervisor:
Prof. Doutor José Carlos Dias, Prof. Associado (com Agregação), ISCTE Business
School, Finance Department

October 2017

Acknowledgments

The outcome of this thesis emerged from the merger of the knowledge gained through the model Futures and Option during the Masters and my professional experience during the last four years, accompanying client's investments.

On the first place, I would like to thank to Professor Doutor José Carlos Dias, for being always available and patient throughout this process, as well as for having accepted to supervise my work.

Secondly, I would like to thank my father and mother for always giving the support, concern and love throughout my 25 years, and for teaching me every day to be the best part of me. Also I would like to thank to my sister and brother, for being the best references I have.

I would specially like to thank to Bernardo, for always believing in me and for having pulled me up during this phase, with his positive energy. Also for all the helpful discussions during the process which had an important contribution to this work and helped to keep me always motivated.

Finally I would also like to thank to *BiG – Banco de Investimento Global*, which provided the professional experience I have today, and the office material to the conclusion of the practical part of the work.

The conclusion of this thesis symbolizes the end of this academic stage, which I acknowledge with great pride and longing.

Abstract

Trading volatility is a challenge to every speculating trader. Rather than prediction whether the price of a certain asset will move upwards or downwards, a trader who seeks to trade volatility, is concerned with how much movement in any direction will occur. Recognizing the difficulty on obtaining return with the most common volatility investment solutions (ETF's, CFD's and futures), one seeks to test an alternative strategy, without being exposed to high levels of risk.

Using data from May through December of 2016, on a back-testing basis, it examines the relative performance of speculation strategies with options, namely the high volatility expectation strategies. Specifically, using three different equity indices, one evaluates the daily returns from the strategies that include long strangle, long straddle and short butterfly spread with calls, when applied on the past data of two political and macro-economic events of 2016: the United Kingdom Referendum and the United States presidential elections.

This thesis proves, that it would have been possible to gain with the volatility occurred on the events of 2016, applying speculation strategies with options, through the usage of real past data.

Keywords: back-testing, volatility trading, speculation strategies, option contracts

G17 – Investment Decisions

G17 – Financial Simulation

Resumo

A negociação de volatilidade é um corrente desafio para todos os *traders* de activos financeiros. No lugar de prever se o preço de um determinado activo se irá valorizar ou desvalorizar, um *trader* de volatilidade procura a quantidade em que o activo se poderá mover em qualquer direcção. Reconhecendo a dificuldade dos investidores de retalho, em obter retorno com as soluções de investimento em volatilidade mais comuns (como ETF's, CFD's e contratos de futuros), procuramos testar estratégias alternativas, com níveis de exposição ao risco, mais reduzidos.

Usando dados de mercado desde maio a dezembro de 2016, aplicando um modelo de *back-testing*, foram aplicados testes ao desempenho relativo de estratégias de especulação com opções, nomeadamente as estratégias de expectativa de alta volatilidade. Concretamente, através do uso de três índices de ações diferentes, avaliamos os retornos diários das seguintes estratégias: *long straddle*, *long strangle* e *short butterfly spread with calls*. As estratégias serão aplicadas em dados de mercado durante os eventos políticos e macroeconómicos de 2016: o referendo do Reino Unido e as eleições presidenciais dos Estados Unidos da América.

Esta tese comprova que teria sido possível obter ganhos com a volatilidade ocorrida nos eventos de 2016, aplicando estratégias de especulação com opções, através do uso de dados passados.

Palavras chave: back-testing, negociar volatilidade, estratégias de especulação, contratos de opções

Table of Contents

CHAPTER 1: INTRODUCTION 1

1.1. INTRODUCTION 1

CHAPTER 2: LITERATURE REVIEW 3

2.1 OPTION MARKETS..... 3

 2.1.1 *Main concepts* 3

 2.1.2 *Underlying assets* 6

 2.1.3 *Pricing an option contract* 8

 2.1.4 *Greek letters* 9

2.2 TRADING STRATEGIES FOR OPTIONS 10

 2.2.1 *Speculation strategies vs hedging strategies*..... 10

 2.2.2 *High volatility Expectation Strategies*..... 11

 2.2.3 *Difficulties on trading high volatility expectation strategies*..... 18

2.3 ECONOMIC AND POLITICAL EVENTS IN 2016 (HIGH EXPECTED VOLATILITY) 18

 2.3.1 *United Kingdom referendum*..... 19

 2.3.2 *United States presidential elections* 23

CHAPTER 3: APPLICATION OF HIGH VOLATILITY EXPECTATION TRADES ON 2016 EVENTS..... 25

3.1 STRATEGIES SELECTION 25

3.2 ASSETS SELECTION 26

 3.2.1 *United Kingdom Referendum*..... 26

 3.2.2 *United States presidential elections* 27

3.3 METHODOLOGY 28

 3.3.1 *Expiration dates* 29

 3.3.2 *Buying dates* 30

 3.3.3 *Assumptions: strike prices and option prices*..... 30

3.4 RESULTS 32

 3.4.1 *‘Brexit’ – Results exposition and analysis* 33

 3.4.2 *US presidential elections – Results exposition and analysis*..... 39

3.5 LIMITATIONS..... 42

CHAPTER 4: CONCLUSION 44

BIBLIOGRAPHY	46
APPENDIX 1	47
APPENDIX 2	84
APPENDIX 3	111

List of Figures

FIGURE 1: PROFIT OR LOSS AT OPTION’S MATURITY FOR CALLS 4

FIGURE 2: PROFIT OR LOSS AT OPTION’S MATURITY FOR PUTS 5

FIGURE 3: PROFIT AND LOSS FROM A LONG STRADDLE 12

FIGURE 4: PROFIT AND LOSS FROM A LONG STRANGLE 14

FIGURE 5: PROFIT AND LOSS FROM A SHORT BUTTERFLY SPREAD WITH PUTS 15

FIGURE 6: PROFIT AND LOSS FROM A SHORT BUTTERFLY SPREAD WITH CALLS 15

FIGURE 7: PROFIT AND LOSS FROM A SHORT CONDOR WITH CALLS..... 16

FIGURE 8: PROFIT AND LOSS FROM A SHORT CONDOR WITH PUTS 16

FIGURE 9: PROFIT AND LOSS FROM A LONG STRAP 17

FIGURE 10: PROFIT AND LOSS FROM A LONG STRIP 18

FIGURE 11: TOP ECONOMIES IN THE WORLD – UNITED KINGDOM POSITION GLOBALLY . 20

FIGURE 12: NET CONTRIBUTION TO THE EUROPEAN UNION, FORM EU COUNTRIES IN 2013
..... 21

FIGURE 13: EVOLUTION OF THE NUMBER OF IMMIGRANTS IN UNITED KINGDOM 22

FIGURE 14: S&P500 DAILY RETURN ON ELECTION DAYS..... 23

FIGURE 15: GERMAN DAX 30 FROM JANUARY 2016 TO AUGUST 2016 36

FIGURE 16: FOOTSE 100 FROM JANUARY 2016 TO AUGUST 2016..... 38

FIGURE 17: S&P 500 INDEX FROM MAY 2016 TO MARCH 2017 41

List of Tables

TABLE 1: BASIC OPTION POSITIONS	3
TABLE 2: ASSETS SELECTION	28
TABLE 3: OPTIONS UNDER STUDY – ‘BREXIT’	29
TABLE 4: OPTIONS UNDER STUDY – US PRESIDENTIAL ELECTIONS	30
TABLE 5: LONG STRADDLE RESULTS - ‘BREXIT’	33
TABLE 6: LONG STRANGLE RESULTS - ‘BREXIT’	34
TABLE 7: SHORT BUTTERFLY SPREAD WITH CALLS RESULTS - ‘BREXIT’	35
TABLE 8: HISTORICAL VOLATILITIES ON GERMAN DAX 30	36
TABLE 9: COMPARISON BETWEEN PAYOFFS OF DAX 30 ON BOTH MATURITIES, ACROSS THE THREE STRATEGIES	37
TABLE 10: HISTORICAL VOLATILITIES FOOTsie 100	38
TABLE 11: COMPARISON BETWEEN PAYOFFS OF FTSE 100 ON BOTH MATURITIES, ACROSS THE THREE STRATEGIES	39
TABLE 12: LONG STRADDLE RESULTS – US PRESIDENTIAL ELECTIONS	40
TABLE 13: LONG STRANGLE RESULTS – US PRESIDENTIAL ELECTIONS	40
TABLE 14: SHORT BUTTERFLY SPREAD WITH CALLS RESULTS – US PRESIDENTIAL ELECTIONS	41
TABLE 15: HISTORICAL VOLATILITIES ON S&P 500	42
TABLE 16: SUMMARY OF RESULTS PER STRATEGY AND EVENT	45

Chapter 1: Introduction

1.1. Introduction

Throughout my experience at *BiG – Banco de Investimento Global* I have been accompanying retail clients on their trading investments, through equities, foreign currencies, futures and CFD's. During the last year, I recognized the client's strong willingness to speculate on the volatility in the financial markets, due to the underlying uncertainty on that year. I observed many investors risking their capital trading on VIX index through ETF's or future contracts. However, this revealed to be an investment of high risk, on which the clients faced unlimited potential losses.

On that point emerged the interest of testing a strategy where the clients could profit from the eventual volatility in the market, tough having limited capital at risk. Financial options seemed to be the financial asset which allowed most flexibility when building a strategy. It gives the possibility to create a variety of different combinations and adjust an investment to almost any chosen profit and loss profile. Remembering the concepts acquired on the model Futures and Options, it arose the idea of testing speculation strategies which could take advantage of the expectation of future evolution on the volatility in the financial markets during 2016. This idea occurred from the need to understand whether the knowledge acquired regarding the speculation strategies with options, could be translated into real returns for the client's portfolios.

Therefore, the aim of this thesis is to test if one can prove the possibility of achieving a positive payoff when using high volatility expectation strategies, during the political and macro-economic events of 2016. On a back-testing model, this work purposes to asses if one would be able to profit, if one had applied high volatility expectation strategies before, and after the described events. Thus, this statement can be presents by the following hypotheses:

Hypotheses I: Achieving a positive result – Can prove the possibility of achieving a positive payoff using high volatility expectation strategies.

Hypotheses II: Not achieving a positive result – Cannot prove the possibility of achieving a positive payoff using high volatility expectation strategies.

The profitability of the strategies will be proved in case any of the strategies achieves a positive result on the tests applied. Since the application of the strategies is used on a back-testing model, one will seek to get as closed as possible to a real application on the past data. It will also be analyzed the consistency of the results obtained, though the detailed analysis of the different variables of the strategies.

The work will be mainly divided in three parts. Chapter 2 discusses the theoretical support on the present topic. It will be discussed the existing speculation strategies with options and the events which provided most volatility in 2016. Chapter 3 discusses the methodology used and sets out the results obtained from the tests applied. Finally chapter 4 draws the main conclusions.

Chapter 2: Literature Review

2.1 Option Markets

2.1.1 Main concepts

Options are derivative contracts, which give the holder the right, but not the obligation, to buy or sell an underlying asset S , at a previously specified strike price K (Black and Scholes, 1973). A contract option that gives the right to buy is called a “call option”, while the one that gives the right to sell is referred to as a “put option”. A European option is one that provides the exercise only at the expiration date T . An American option allows the exercise at any time until the date the option expires.

2.1.1.1 Basic positions and payoffs

As in most financial instruments, one may open a position in two different directions: a long and a short position in an option contract.

A long position in a call/put option is opened by the purchase of a call/put contract option, giving one the right to buy/sell the underlying asset. Contrarily, a short position in a call/put option is acquired through the sale of a call/put contract option. The holder of the short call or short put is obliged to sell or buy the underlying asset, respectively.

Positions	Call option	Put option
Long positions	Long call (right to buy)	Long put (right to sell)
Short positions	Short call (obliged to sell)	Short put (obliged to buy)

Table 1: Basic option positions

When talking about option contracts, one has to understand the details of the contract, which are specified by the exchange:

Strike price: The strike price of an option contract is the defined price per share, for which the underlying asset would be purchased or sold (purchased for a call and sold for a put), by the option holder, at the exercise date of the option contract.

Expiration date: One of the principal items used to describe an option contract, is the month in which the expiration occurs. The expiration date is the day before the last day on which options trade. Usually the precise expiration date is the Saturday immediately following the third Friday of the expiration month, which is the last options trading day.

Considering European options, the payoffs at the exercise date may be defined by the following functions:

$$\text{Long call} = \max[S_T - K, 0], \quad (1.1)$$

$$\text{Short call} = -\max[S_T - K, 0] = \min[K - S_T, 0], \quad (1.2)$$

$$\text{Long put} = \max[K - S_T, 0], \quad (1.3)$$

and

$$\text{Short put} = -\max[K - S_T, 0] = \min[S_T - K, 0], \quad (1.4)$$

where K is set as the strike price or exercise price and S_T is defined as the price of the underlying stock at expiration date. The above functions consider that there are no transaction costs and that it is possible to borrow and lend at a risk-free rate.

The payoffs do not include the option premium, paid up front. Thus, the payoff for long positions is either positive or null, since the option holder is not obliged to exercise the option contract when $S_T < K$ (call) and $S_T > K$ (put). However, to determine the outcome of the option (profit or loss) one has to take into account the option premium. For long positions the premium should be subtracted to the payoff, while for short positions the premium should be summed up to the payoff. Figure 1.1 and 1.2 show the graphical representation of the profit or loss for standard options at maturity.

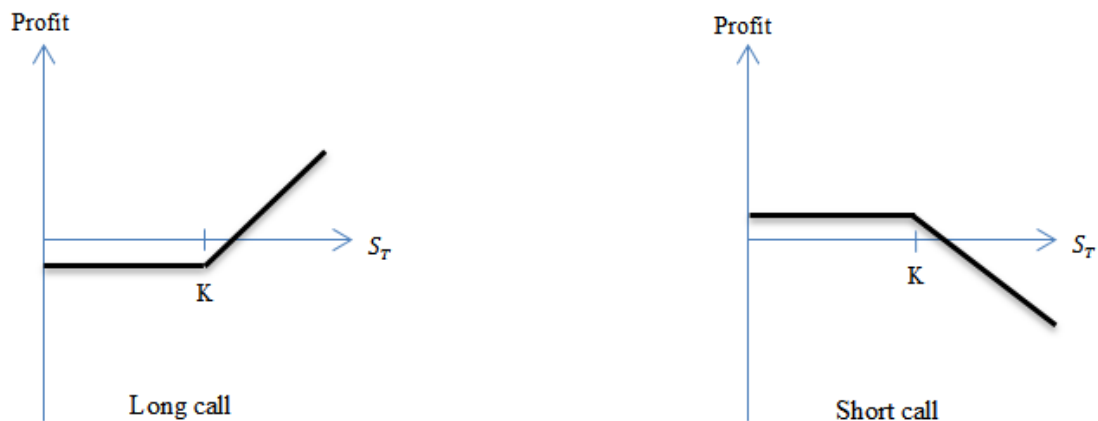

Figure 1: Profit or Loss at option's maturity for calls

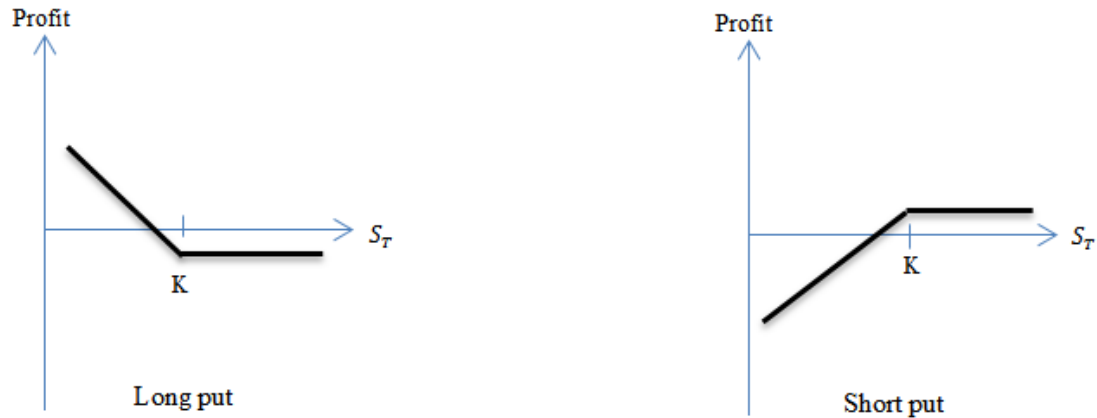

Figure 2: Profit or Loss at option's maturity for puts

Long positions on call options have an unlimited profit and a limited loss to the premium paid. A long position on a put option has a limited profit when the underlying price is equal to zero, and a limited loss to the premium paid. In case of short positions, both, calls or puts, have a limited profit to the premium paid by the option holder. The potential loss on call options is unlimited, while on put options it is limited to the moment when the underlying price achieves the value of 0.

The option premium might be split in two elements: the *intrinsic value*, and the *time value*. The *intrinsic value* is the cash flow achieved by the immediate exercise of the option contract, while the *time value* consists of the difference between the premium and the *intrinsic value*. As the option approaches its expiration date, the *time value* will tend to be closer and closer to \$ 0, whereas the *intrinsic value* will closely represent the difference between the underlying security's price and the strike price of the contract. The *time value* is a result of the probability of an advantageous move on the underlying asset's price, until the expiration date. Thus, on expiration *time value* is equal to zero. The *total value* of an option is the sum of its *intrinsic value* and its *time value*.

When comparing the spot price of the underlying asset of a call or a put option with its strike price, there might be one of 3 possibilities:

ITM: An option contract is in-the-money when its intrinsic value is positive. When the option contract is ITM at expiration date, then the option holder should exercise the option.

ATM: An option contract is at-the-money when its intrinsic value is zero, i.e. when it is indifferent to exercise or not exercise the option contract.

OTM: An option is out-of-the-money in case the exercise of the option results on a negative payoff.

To exemplify, suppose an investor that buys at $t=0$ a European call option for $C = 5$. The call option gives the investor the right to buy 100 shares of a certain stock, at $t=T$, for the price of $K = 60$. The expectation of the option buyer is that $S_T > K + P$, at expiration date T . Now suppose that at time T , $S_T = 75$. The easiest way for the investor to proceed would be to buy for the strike price of 60 and sell it right after by the market price 75, achieving a profit of 10 ($- 5 - 60 + 75$). Contrarily, if $S_T < K$, the investor would do nothing with the contract expiring out of the money, resulting in a loss of 5¹.

Evidently, an option will only be exercised when it is in the money (ITM). Even, in the nonappearance of transaction costs, an ITM option will always be exercised on the expiration date.

2.1.2 Underlying assets

The present section will address the principal underlying assets of an option contract:

- Stock options;
- Index options;
- Foreign currency options;
- Futures Options.

2.1.2.1 Stock options

Stock options mostly trade on exchanges, which include the CBOE (Chicago Board Options Exchange), the NASDAQ OMX, the NYSE Euronext, the International Securities Exchange and the Boston Options Exchange. An option contract gives the holder the right to buy/sell 100 shares.

2.1.2.2 Index option

Index options trade in both the over-the-counter market (OTC) and the exchange-traded market (mentioned above, in the stock options description). The principal index options trade on the CBOE and are those contracts on the S&P500 Index, NASDAQ-100 and

¹ In this example, the time value of money is associated to the call option premium has been ignored.

Dow Jones Industrial Index. Most of the index options are European options, and their expiration date is generally the third Friday of the expiration month, unless that day is a holiday. The last trading day will be the business day preceding the day on which the exercise settlement value is calculated.

Once the underlying asset of a stock index option is a portfolio of stocks, these options are not subject to physical liquidation. Options on indices are settled in cash, which means that on exercise of the option, the holder receives the difference between the value of the index and the strike price, in cash. The writer of the option pays the same amount in cash (index price minus de strike price for calls; strike price minus the index price for puts).

Similarly to stock options, one index option contract usually gives the holder the right to buy/sell 100 times the index. The payoffs for index option contracts are the following:

$$\text{Long call index option} = \max[S - K, 0] \quad (2.1)$$

$$\text{Long put index option} = \max[K - S, 0] \quad (2.2.)$$

where S is the index price at the time of exercise and K is the strike price.

2.1.2.3 Foreign currency options

Contrarily to stock options, most currency options trade in the over-the-counter market, even though there is some exchange trading. In the USA, the exchange which trades foreign currency options is the NASDAQ OMX, offering European-style options. In that case, one contract enables the purchase/sale of 10.000 units of a foreign currency. Although the NASDAQ OMX enables trading on currency options, this exchange-traded market is much smaller than the over-the-counter market, which offers the advantage of enabling large trades, with strike prices, expiration dates and other features, tailored to the needs of corporate investors.

2.1.2.4 Futures options

A future option gives the holder the right do buy/sell a position in a futures contract, at a certain futures price, by a certain date. The holder of a call/put future option, in case the option is exercised, acquires a long/short position in the underlying futures contract, plus the cash amount equal to the difference between the most recent settlement futures

price and the strike price (future price minus de strike price for calls; strike price minus de future price for puts). Thus, the effective payoffs from a future option contract are the following:

$$\text{Long call future option} = \max (F_T - K; 0) \quad (2.3)$$

$$\text{Long put future option} = \max (K - F_T; 0) \quad (2.4)$$

where F_T is the futures price at the time of exercise and K is the strike price.

Generally, the exchanges which offer future contracts also offer options on that contract. Options on future contracts are usually American, and its expiration date is generally the first Friday of the expiration month.

2.1.3 Pricing an option contract

When it comes to the pricing of European call options, there are at least six variables that might affect the value of a call option: the price of the underlying asset, the strike price, the volatility of the stock price, the time to maturity, the risk-free interest rate and the dividend rate of the stock (Bodie et al, 2003). Black and Scholes (1973) and Merton (1973) accomplished the major development in the pricing of European stock options, which has evolved to the today known Black-Scholes-Merton model.

The price of a call option should increase in value with the stock price and decrease with the strike price. It should be clear that the higher the price of the stock, the greater the value of the option. This common rule is due to the fact that the payoff of a call, when exercised, is $S_T - K$. The present value of the option is “approximately equal to the price of the stock minus the price of a pure discount bond that matures on the same date as the option, with a face value equal to the striking price (Black and Scholes, 1973)”. Contrarily, the option value is near to zero as long as the stock price is much lower than the strike price.

The maturity is also a variable that influences significantly the way of pricing an option. As the maturity date of the option contract is closer, the value of the option declines, when the value of the stock does not change. Whenever the expiration date is distant in the future, then the price of a bond that pays the exercise price on the maturity date will be low. Thus the value of the option will be very close to the price of the stock. On the contrary, if the expiration date is very close, the value of the option will be near to the

call option payoff, in case the stock price is higher than the exercise price, or zero, if the stock price is lower than the exercise price.

The price of an option also depends on the risk-free interest rate. It affects the price in so far as when interest rates increase in the economy, the evolution from the stock expected by the investors tends to increase. Thus, the present value of any future cash flow obtained by the holder of the option decreases. Both effects combined result on the rise of the value of the call option, and the decrease of the value of the put option. Consequently, the put options price drops as the risk-free interest rate rises. On the other hand, for calls, the price of the option always increases when the risk-free interest rate increases.²

When it comes to volatility, considering a weak stock performance, in which the option expires out of the money, in both scenarios (high/low-volatility stocks) the payoff would be zero. However, in a good stock performance, in which the call option would expire in the money, the probability to achieve a greater stock price is higher in high-volatility scenario. On the edge, extremely good stock results, improve the option payoff with no limits, while weak outcomes cannot deteriorate the payoff below zero. Thus, the expected payoff of a certain stock option might be higher in the presence of volatility, which in turn boosts its value.

Lastly, a stock that has a high-dividend payout policy might face limitations on the rate of growth of the stock price. That effort on the stock price rise reduces the potential payoff from the call option, leading to a lower call value.

2.1.4 Greek letters

When pricing an option contract one cannot forget to take into account the Greek letters.

Starting by the most used parameter and referring to stock options, the **delta** of a stock option “is the ratio of the change in the price of the stock option to the change in the price of the underlying stock” (Hull, 2008). Delta represents the number of units of the stock that one should hold, for each option shorted, in order to achieve a riskless portfolio. In a mathematical view, it is the first derivative of the option’s price relative to a change in the price of the stock.

² The mentioned effects assume that all other variables remain fixed.

Considering European options on a non-dividend paying stock, the delta of a call option is positive, as soon as the premium of the option increases as the price of the underlying also increases. Thus, a deep ITM call would have a delta close to 1, an ATM call would have a delta of approximately 0.5 and an OTM call would have a delta close to 0. Contrarily, the delta of a put option is negative, once its premium decreases as the price of the underlying increases. Therefore, an ITM put has a delta close to -1, an ATM put close to -0.5 and an OTM put a delta of approximately 0.

Gamma is strongly related to Delta, because it represents the change in an option's Delta, relative to a one unit change in the price of the stock. Mathematically, it is the second derivative of an option's premium relative to a change in price of the stock. In this case, Gamma is the same for call and put options.

Vega is the change in the price of an option's contract, for a 1% change in volatility. Similarly to the Gamma, Vega is the same for calls and put.

Theta is a measure related to time. When Theta as a negative sign, it indicates that the time to expiration of the option is declining and the value of the option is decaying.

Finally, **Rho** measures the sensitivity of the value of an option, to a change in the interest-rate.

2.2 Trading strategies for options

Besides the profit that investing in options may provide, one may benefit from the conjunction of options with other assets. These combinations might be used to create different trading strategies. Two of the most popular trading strategies are hedging and speculation strategies.

2.2.1 Speculation strategies vs hedging strategies

Speculation strategies are built with option contracts, either single options or option combinations and options spreads. An option contract combination is the combination of puts and calls, while option spreads are a mix of only puts or calls with different strike prices. These strategies are generally linked to a certain expectation on the future evolution of the financial markets. This strategies aim to take advantage of an expectation about 1) the underlying asset price, which are referred as the price expectation trades, and 2) the volatility of the underlying asset price, which are called

the volatility expectation trades. Within the speculation strategies one consider three different groups: price expectation trades, low volatility expectation trades and high volatility expectation trades.

Speculation strategies using options are especially interesting in the sense that they might limit the risk to a tailored to a desired level, wherein the maximum loss can be the premium that has been paid. Furthermore, with option contracts one might be exposed to an unlimited profit potential, since the investment is delimited to the premium paid. Additionally, with option contracts an investor is able to construct an enormous diversity of payoff profile, adjusted to the investor's desire.

Contrarily to speculation strategies, hedging strategies through option contracts consist of acquiring a position in an option and in the respective underlying asset. The main aim of hedging strategies with options is to cover any position and risk one may have in a spot position. Hedging strategies might be split into 1) simple hedging strategies and 2) complex hedging strategies. The former involve a single position in the options market, where a spot position is hedged through a single option contract. The latter comprises more than one position in the options market.

The present thesis will focus on the speculation strategies, namely the ones that intend to benefit from the volatility in the financial markets: the high volatility expectation strategies.

2.2.2 High volatility Expectation Strategies

When there are expectations of high volatility in the market or in a certain underlying asset, one might apply one of the following speculation strategies:

- Long straddle;
- Long strangle;
- Long strap;
- Long strip;
- Short butterfly spread with calls or puts;
- Short condor with calls or puts.

The mentioned strategies might be split into two main groups: 1) the non-directional options strategies; and 2) the directional option strategies.

2.2.2.1 Non-directional options strategies

The non-directional option strategies benefit from a significant market move - up or down - of the underlying asset, when it comes to long positions, or if the price moves sideways, regarding short positions. Some non-directional option strategies are also delta neutral. As referred in section 2.1.4., delta is the change in an option's price relative to a unit change in the price of the stock. Therefore, a strategy is delta neutral when the sum of the deltas of the calls and puts is equal or even close to zero. A delta neutral position reduces the directional component in the value of the position. In case of a long straddle or long strangle (presented below) these are delta neutral, once the positive delta of the call offsets the negative delta of the put.

Long straddle

The long straddle strategy involves buying a European call and put, both with the same strike price and expiration date and both usually at the money. This strategy leads to a loss if the underlying asset's price is close to the strike price at expiration. On the other hand, if there is sufficient large move in either, positive or negative direction, the strategy may result in an unlimited profit. Thus, the long straddle is adequate when the investor expects high volatility in the underlying asset, though does not have any specific expectations regarding the move direction. The expected payoff of a long straddle strategy is the following:

$$\begin{aligned} \text{Long straddle} &= \text{Long Call (K)} + \text{Long Put (K)} & (3.1) \\ &= \max[S_T - K, 0] + \max[K - S_T, 0] \end{aligned}$$

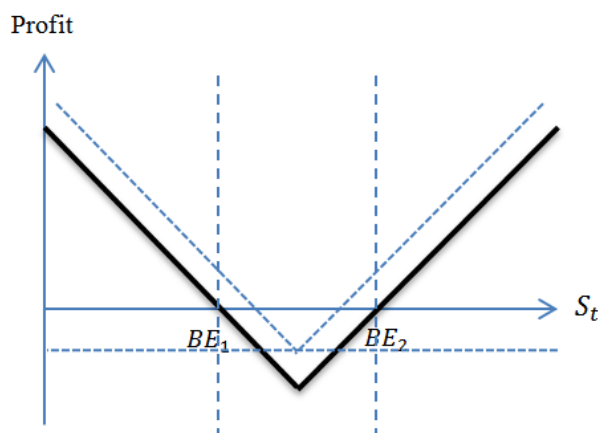

Figure 3: Profit and loss from a long straddle

BE_1 and BE_2 refer to the points at which it is indifferent for the investor to exercise or not the option, called break-even points. These are calculated as follows:

$$BE_1: S_T = K - \text{premium} \quad (3.2)$$

$$BE_2: S_T = K + \text{premium} \quad (3.3)$$

Long strangle

Similarly with the long straddle, in the long strangle the investor does also expect a large price move, though does not have any specific expectation in which direction the move will be. Also, the long strangle strategy does consist of a position in a long call and a long put. What differs in these two strategies is that in the long strangle the strike prices of both positions are different. The strike price of the long call is higher than the strike of the long put.

$$\text{Long strangle} = \text{Long put } (K_1) + \text{Long call } (K_2), \text{ with } K_1 < K_2 \quad (4.1)$$

$$= \max[K_1 - S_T, 0] + \max[S_T - K_2, 0]$$

$$BE_1: S_T = K_1 - \text{premium} \quad (4.2)$$

$$BE_2: S_T = K_2 + \text{premium} \quad (4.3)$$

When comparing both strategies, in the long strangle the underlying asset's price needs to move farther than in the long straddle, for the investor to end up with a positive result. On the other hand on the long strangle the downside risk is lower than on a long straddle. The profit or loss of this strategy depends on the distance of both strike prices from each other. As farther they are, the lower the downside risk will be, and the farther the underlying price will need to move to achieve the break-even point. Thus, the closer the strike prices get, the similar the strategy will be from long straddle.

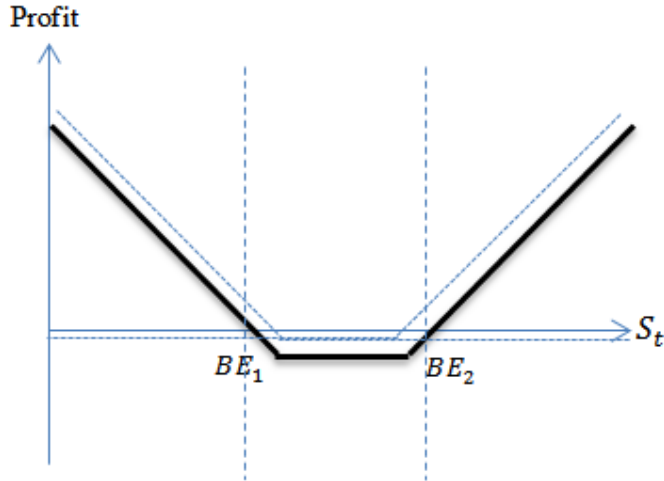

Figure 4: Profit and loss from a long strangle

Short Butterfly Spread with calls or puts

The short butterfly spread with calls (puts) strategy, consists on the creation of three different positions: selling a lower (ITM) strike call (put), selling a higher (OTM) strike call (put) and buying two (ATM) calls (puts) with a strike price of the central value of the previous two strike prices. All call (put) options have the same expiration date.

Short butterfly spread with calls = Short call (K_1) + short call (K_2) + 2 long call (\bar{K})

$$\text{with } K_1 < K_2 \text{ and } \bar{K} = \frac{K_1 + K_2}{2} \quad (5.1)$$

$$= -\max[S_T - K_1, 0] - \max[S_T - K_2, 0] + 2 \times \max[S_T - \bar{K}, 0]$$

Short butterfly spread with puts = Short put (K_1) + short put (K_2) + 2 long put (\bar{K})

$$\text{with } K_1 < K_2 \text{ and } \bar{K} = \frac{K_1 + K_2}{2} \quad (5.2)$$

$$= -\max[K_1 - S_T, 0] - \max[K_2 - S_T, 0] + 2 \times \max[\bar{K} - S_T, 0]$$

$$BE_1: S_T = K_1 + \text{net premium received} \quad (5.3)$$

$$BE_2: S_T = K_2 - \text{net premium received} \quad (5.4)$$

An investor who trades short butterfly spreads with calls or puts expects great price moves in the market. This strategy leads to the same payoff when built with calls or puts. A loss is generated when the underlying price ends up close to \bar{K} at expiration date, and generates a gain, though a small gain, if the underlying price has a significant move, either in a positive or negative direction.

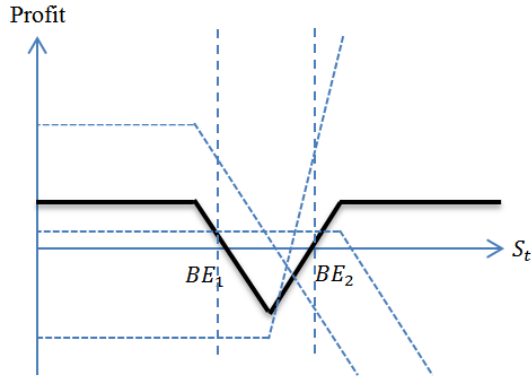

Figure 5: Profit and Loss from a Short Butterfly Spread with puts

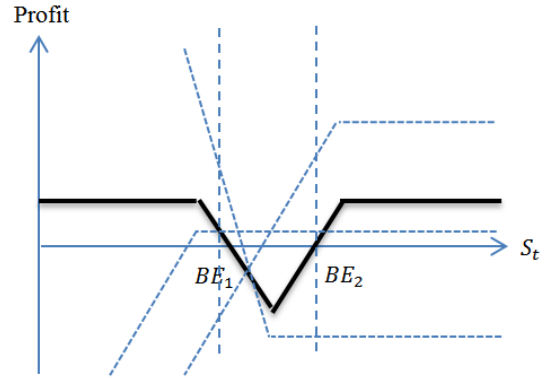

Figure 6: Profit and Loss from a Short Butterfly Spread with calls

Short Condor with Calls or Puts

The short condor with calls or puts is built through four different positions: selling an ITM call (put) with a strike K_1 ; buying an ITM call (put) with a strike K_2 ; buying an OTM call (put) with a strike K_3 ; selling an OTM call (put) with a strike K_4 . A short condor with calls (puts) requires the same expiration date for all call (put) options.

This is a neutral strategy with limited risk and limited profit. The maximum loss of a short condor strategy is at the center of the option spread. The maximum gain occurs when the underlying asset is trading before/after the lower/upper strike prices.

$$\text{Short Condor with Calls} = \text{short call } (K_1) + \text{long call } (K_2) + \text{long call } (K_3) + \text{short call } (K_4), \text{ with } K_1 < K_2 < K_3 < K_4. \quad (6.1)$$

$$= -\max[S_T - K_1, 0] + \max[S_T - K_2, 0] + \max[S_T - K_3, 0] - \max[S_T - K_4, 0]$$

$$\text{Short Condor with Puts} = \text{short put } (K_1) + \text{long put } (K_2) + \text{long put } (K_3) + \text{short put } (K_4), \text{ with } K_1 < K_2 < K_3 < K_4. \quad (6.2)$$

$$= -\max[K_1 - S_T, 0] + \max[K_2 - S_T, 0] + \max[K_3 - S_T, 0] - \max[K_4 - S_T, 0]$$

$$BE_1: S_T = K_1 + \text{net credit} \quad (6.3)$$

$$BE_2: S_T = K_4 - \text{net credit} \quad (6.4)$$

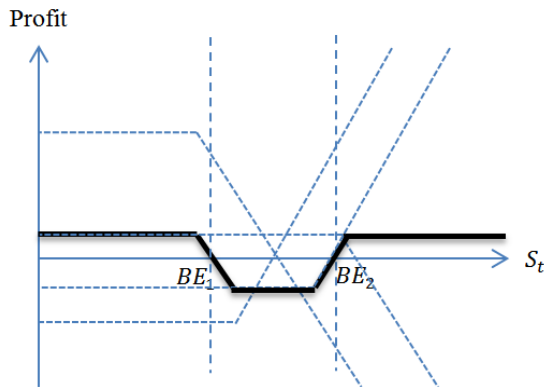

Figure 7: Profit and loss from a short condor with calls

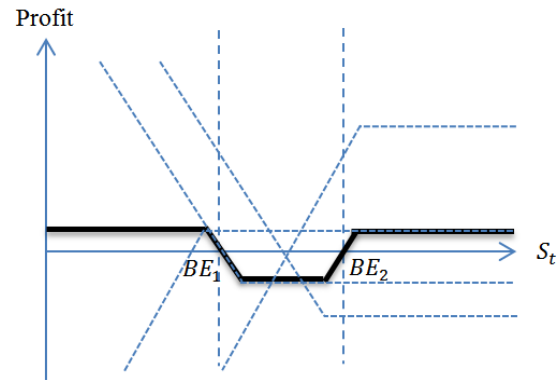

Figure 8: Profit and loss from a short condor with puts

2.2.2.2 Directional options strategies

Contrarily to the non-directional, the directional option strategies are based on the investor's assessment of the global market or a certain security's direction. Traders who trade directional strategies usually have a specific conviction about the market or security's near term direction. In the strategies that are going to be presented next, the investor is betting that there will be a great price move, as well as considers being more likely that the underlying asset will take a certain direction, either upwards or downwards.

Long strap

The long strap comprises the purchase of two European call options and a put option, with the same strike price and expiration date. When using a long strap, the investor expects high volatility in the market, however considers a positive move in the underlying asset more likely. In a long strap, the investor has a negative result when the strike price is close to the underlying asset's price at expiration, and a positive result when the strike price is distant from the underlying's price. Nevertheless, the loss profit and loss pattern is not symmetrical (as is does in a long straddle). The loss area is larger when the strike price is higher than the underlying price at expiration.

The expected payoff of a long strap strategy is the following:

$$\text{Long strap} = 2 \text{ Long Call (K)} + 1 \text{ Long Put (K)} \quad (7.1)$$

$$= 2 \max[S_T - K, 0] + \max[K - S_T, 0]$$

$$BE_1: S_T = K - \text{premium (2 x calls)} \quad (7.2)$$

$$BE_2: S_T = K + \text{premium (puts)} \quad (7.3)$$

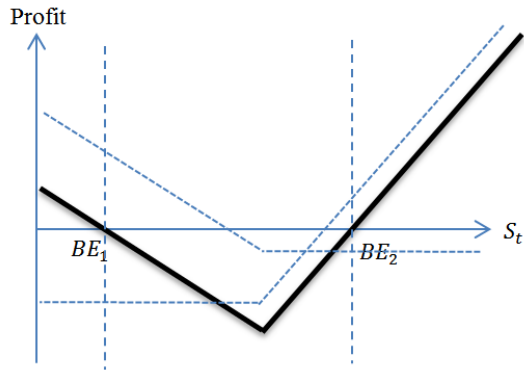

Figure 9: Profit and Loss from a long strap

Long strip

The long strip strategy consists of buying one European Call and two Puts, with the same strike price and expiration date. The expected payoff is the following:

$$\text{Long strip} = \text{Long Call (K)} + 2 \text{ Long Put (K)} \quad (8.1)$$

$$= \max[S_T - K, 0] + 2 \max[K - S_T, 0]$$

$$BE_1: S_T = K - \text{premium (call)} \quad (8.2)$$

$$BE_2: S_T = K + \text{premium (2 x puts)} \quad (8.3)$$

One may say that the long strip strategy is the opposite of the long strap. Both expect a significant move in the underlying asset price; however the long strip applies a higher probability of a negative move in underlying asset's price. Thus, the loss area is larger when the strike price is lower than the underlying price at expiration.

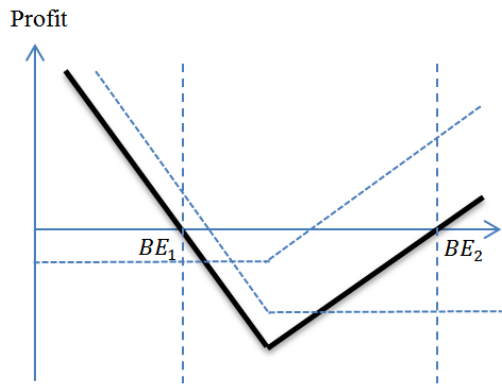

Figure 10: Profit and Loss from a long strip

2.2.3 Difficulties on trading high volatility expectation strategies

When talking about financial markets, one has to take into consideration that the prices integrate the investor's views.

Accordingly to the theory of Dow, all the information available in the market gets reflected in the price of the assets (Murphy, 1990). Any political, economic, social, psychological, or other factor, that might influence the demand and supply on a certain market, will certainly imply movements on the assets traded on that market (Peixoto, 2003). This does not mean that those factors have to be predictable; however, as that information gets public and widespread in the financial markets, the prices of the assets will get affected. Therefore, all the information is discounted in the asset's prices.

Thus, the greatest difficulty when trading high volatility expectation strategies is to anticipate a move in the market that most of the market participants are not able to do. If an investor's expectation of the market is the same as that of other investors, option prices will reflect that view, and consequently will become more expensive. In that case, a bigger move on the underlying asset's price would be necessary for the investor to make a profit.

2.3 Economic and Political Events in 2016 (high expected volatility)

During the year of 2016, a series of big events, which could lead to big surprises, shaped the financial markets:

- i. United Kingdom referendum (called 'Brexit') – June 2016;
- ii. USA presidential elections – November 2016;

- iii. Italy referendum – December 2016;
- iv. Federal Reserve meeting – December 2016;
- v. European Central Bank meeting – December 2016.

Each event implied an outcome of different decisions, whether by the British, American or Italian people, or by the Federal Reserve or the European Central Bank. The decisions related to the different events entailed high levels of uncertainty, since each event had a scenario of high risk.

As in financial markets a high level of uncertainty turns into high volatility, one could anticipate that the events would lead to big moves in the market. Therefore, one might test if it would be possible to profit from the expected volatility, through the application of the trading strategies described in chapter 2.2.2.

In this work, one will focus on two of the above mentioned events: the United Kingdom Referendum and the USA presidential elections, once these were the most widely spoken on media, and the ones which entailed higher uncertainty in a political and economic view. Consequently, these also were the events on which the investors expected higher levels of volatility in the market.

Before applying the strategies on each event, one need first to comprehend what each event comprises, i.e. what were the different expected results and what were the most affected assets. Thus, the current chapter aims to study each event and understand the reason why it was expected a high level of volatility.

2.3.1 United Kingdom referendum

On the 23rd June 2016, the people of the United Kingdom voted to leave the European Union in a referendum. This event has been named by the expression 'Brexit' which resulted from the junction of two words: Britain and Exit. This referendum was a major event in the financial markets given the relevance of the British economy. After 23 years of European Union membership, a potential abandonment would lead the United Kingdom to completely redefine itself.

In 1957, the Treaty of Rome created the European Economic Community (EEC) with the aim of establishing a common European market. The countries Belgium, Luxembourg, France, Italy, the Netherlands and West Germany, were their founding

countries. The United Kingdom joined it later in 1973. In 1975, two years after the United Kingdom entered the EEC, a referendum was held on whether or not the country would remain in the community. The result of the vote was favorable to the permanence.

The Britain's were once again called upon to rule on whether or not the country should remain in the common bloc, on the 23rd of June, 2016. Under Article 50 of the Treaty of Lisbon, any State has the right to voluntary abandon the European Union.

The referendum was centered on two main ideas: believing that the benefits of leaving the European Union would be the best for the United Kingdom and, on the contrary, understanding that leaving the common bloc would not be the best future for the United Kingdom. In this context, there were two groups of people with different interests in this referendum. On one side there were the pro-exit, who thought that the United Kingdom loses sovereignty by being subject to the rules of the European bloc. On the other hand those who believed that the alliance with neighboring countries makes the region more powerful. Those who wanted a free UK have framed the debate in terms of sovereignty, border control and especially immigration.

The figure below shows data proving the economic importance of the United Kingdom both in the European Union and globally.

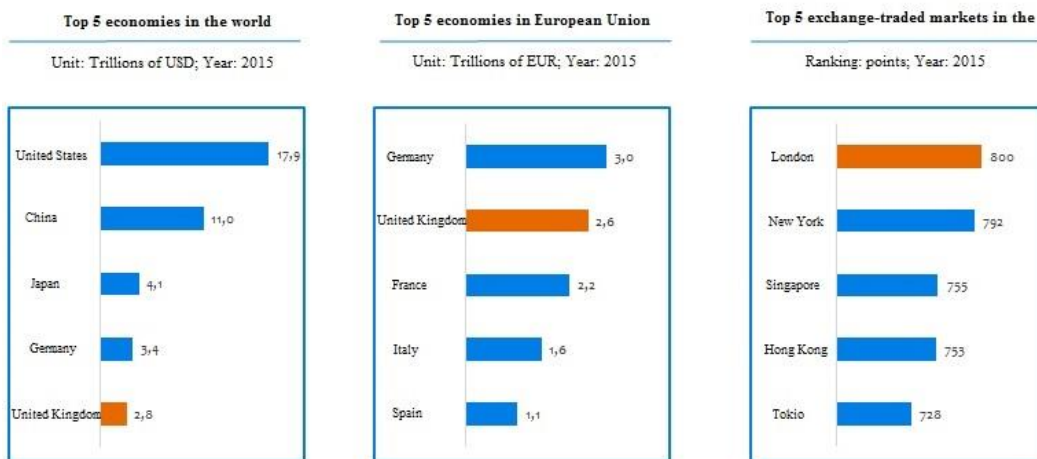

Sources: FMI, Eurostat, Global Financial Centres Index

Figure 11: Top economies in the world – United Kingdom position globally

In the figure above, one might verify that the United Kingdom represents the fifth largest GDP in the world, with 2.8 trillions of USD. Analyzing all the member states of

the European Union, the United Kingdom is right after Germany. Regarding the main stock markets, the London Stock Exchange appears as the most important one, taking into account the ranking of the Global Financial Centers Index.

Concluding the importance of the United Kingdom in Europe, it will be interesting to understand the motivations of those who advocate leaving the country of the European Union. The defenders of 'Brexit', focused essentially on three arguments. The first argument concerns the fact that the United Kingdom wanted to regain the sovereignty of the British parliament. Currently, between 15% and 55% of the laws applied in the UK, come from the EU. On the other hand, the EU High Court is the last instance of all EU courts over the British High Court. In addition, 'Brexit's' advocates still complain about the lack of transparency of EU institutions. The fact that the EU accounts have never been approved by the auditors in the last 19 years, is an example of this. The election process of the European Commission itself is opaque and undemocratic. Still linked to the lack of transparency, once a month all members of the European Parliament move between Brussels and Strasbourg, spending around 180 million euros a year with these transfers. Finally, there is a feeling that unelected bureaucrats have too much power and receive high wages without paying taxes.

The following consideration is that the United Kingdom is the third country in the European Union to pay the highest tax. As it might be visible on the figure below, only Germany and France pay more taxes than the United Kingdom, being the third net taxpayer.

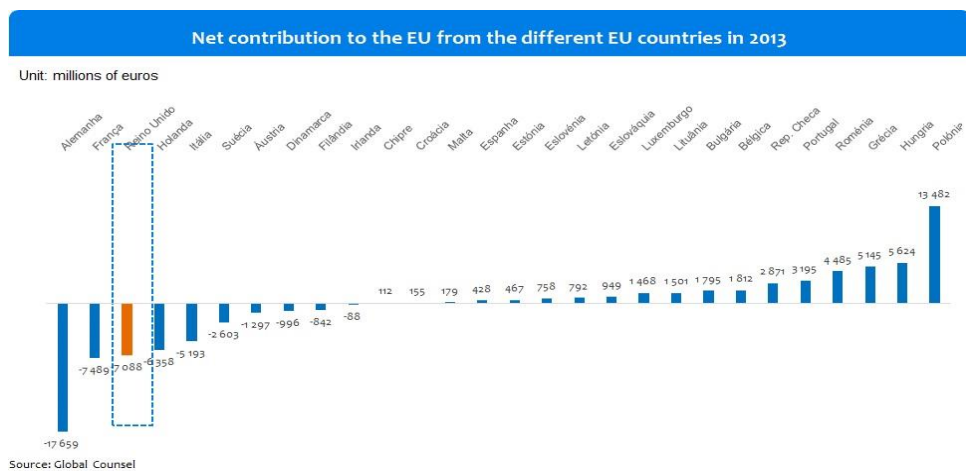
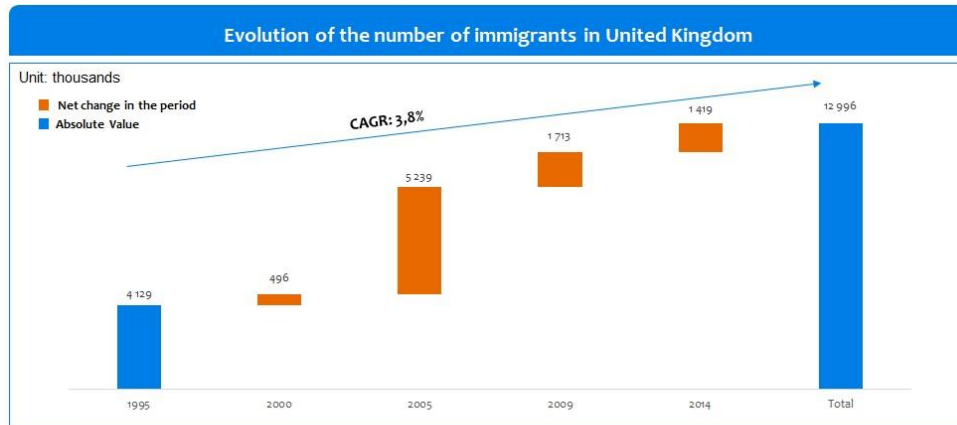

Figure 12: Net contribution to the European Union, from EU countries in 2013

The final argument is that ‘Brexit’s’ advocates believe that immigration into the country is uncontrolled and attribute it to the EU. The next figure shows the evolution of the number of immigrants on the UK from 2000 to 2004.



Source: Global Counsel

Figure 13: Evolution of the number of immigrants in United Kingdom

Regarding the arguments in favor of the permanence of the United Kingdom in the EU, they focus essentially on the UK's external dependence on the member countries. The EU is one of the world's four main trading blocs, along with NAFTA, ASEAN and MERCOSUR. According to a Global Counsel source in 2004, 47% of UK exports went to countries within the EU. For imports, 57% of imports from the British economy were made to EU countries.

Considering all the economic factors mentioned it gets clear that a potential abandonment of the United Kingdom of the European Union would have a great impact on the financial markets, at least on the short term. Thus, one considered that the main assets expected to achieve volatility on an occurrence of ‘Brexit’ were a) the Footsie 100 index, as the reference index in the United Kingdom; b) the British pound, as the transacted currency in the British economy; c) the German DAX 30 index, as the main reference index in the European bloc; and d) the Euro, as the transacted currency in the European Zone. Naturally there would have been additional asset which might be affected by an occurrence of ‘Brexit’, even though, these were the ones considered as most directly affected.

2.3.2 United States presidential elections

Regarding the United States Elections, whose vote took place on 8th November 2016, this is an event that directly attracts the attention of the market, since it is talking about the presidential elections of the world's largest economy.

It was the country's 58th presidential election, which officially elected the president and vice president of the United States of America. The president Barack Obama, was ineligible for a third term, due to deadline limits as the nation's leader. The presidential elections in the United States always had a significant impact on the international system and consequently on the financial markets. In addition to the United States being the world's largest economic power, its ability to influence international affairs continues to manifest itself politically and militarily, economically and commercially, and even culturally and ideologically.

Therefore, a change in the presidency of the country was expected to be translated into uncertainty in the financial markets and consequent associated volatility. Analyzing the reaction of the market in previous elections, it is visible that the reaction of the market tends to be descending when the president changes. In figure below, one might observe the return of the S&P 500 index, on past Election Days:

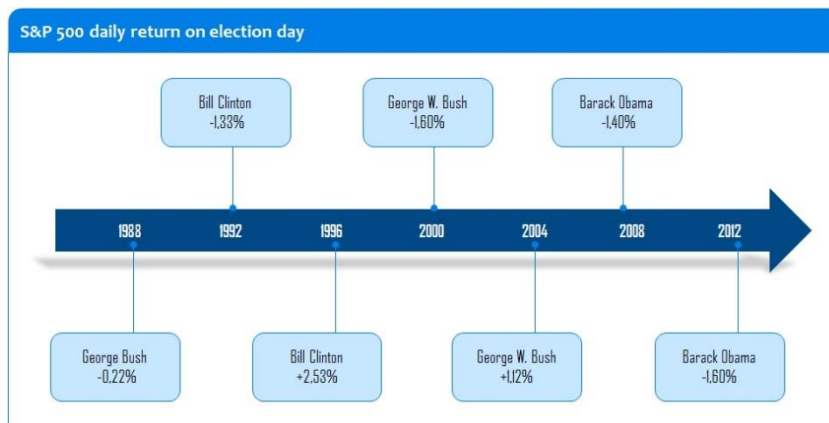

Figure 14: S&P500 daily return on Election Days

Source: Bloomberg

However, in addition to the implied significance of the event, these elections were reason of a further concern, due to the fact that the republican candidate had a set of radical ideas. Donald Trump throughout his election campaign, assumed himself as a candidate on the fringe of the system. In order to better understand, the character and

position of the candidate Donald Trump, some of their promises during their campaign will be pointed out:

- Renegotiate the free trade agreements signed by the USA;
- To impose tariffs on imports from China;
- Increase U.S. military by 540,000 active troops;
- Rebuild the "US Navy" to meet the request of 350 warships;
- Provide US air forces with 1,200 combat aircraft;
- Building a Wall between US and Mexico;
- Achieving US energy independence, not relying on other countries for their energy supply;
- Favor the use of natural gas and other energy sources to reduce energy costs and improve the economy;
- Reduce and eliminate Obama's legislation for responsible energy production;
- Reduction of corporation tax and personal income tax.

Donald Trump went to compete for the US presidency with Democrat Hillary Clinton. Thus, the presidential Election Day has been awaited with some fears from investors regarding the likelihood of Donald Trump victory. Political uncertainty and instability preceded the Election Day. Thus, one considered this event as an event of expected volatility. The final result ended up giving the Republican candidate victory.

Bearing in mind the political and economic factors mentioned, regarding the US presidential elections, one might agree that there were some underlying risks to the Election Day of November 2016, which could lead to significant levels of volatility in the financial markets. The main assets expected to mostly achieve volatility after the Election Day were a) the main US equity indices as the S&P 500 index, the Nasdaq 100 index, and the Dow Jones Industrial Average index; b) the U.S. Dollar Index, as the measure of the U.S. Dollar relative to the value of a basket of currencies; and c) United States government bonds. Certainly there would have been additional asset which might be affected, such as the Mexican Peso, due to the intention of creating a Wall between the U.S. and Mexico. Nevertheless, the asset mentioned were the ones considered as most directly influenced.

Chapter 3: Application of high volatility expectation trades on 2016 events

The present chapter aims to apply high volatility expectation strategies on the events of 2016 described in section 2.3. Firstly, it will be discussed which strategies have been used. Secondly, it will be defined in which assets the strategies will be tested and the methodology for the implementation of the strategies. Moreover, one will enumerate the limitations that have been found when applying the strategies. Lastly, one will analyze the obtained results.

3.1 Strategies selection

As referred in the introduction, the main objective of the thesis is to test the profitability of high volatility expectation strategies during the events of 2016. In chapter 2.3 one concluded that the described events of 2016 entailed high levels of uncertainty, defining the assets in which it was most expected high volatility. Thus, the underlying uncertainty brought forth expectations of achieving high levels of volatility, yet without a concrete conviction about the trend that the market would follow. Both events implied a specific decision. The decision of each event could result in a variety of movements, without the investor being certain of what result would lead to which movement. For that reason, when choosing the strategy, one might eliminate the *long strip* and *long strap*, which have a specific expectation regarding the trend of the underlying assets.

Consequently, one might work with the remaining four strategies, the non-directional option strategies, which do not specifically expect the market to go up or down: *long straddle*, *long strangle*, *short butterfly spreads* and *short condors*.

While analyzing the four strategies, one might bunch the four strategies in two groups. The *long strangle* and the *short condor* with calls or puts, require a bigger move of the underlying asset's price in order to achieve a profit, when compared to the *long straddle* and *short butterfly spread* with calls or puts, respectively. The latter options need a lower move of the underlying asset's price to achieve a profit, due to the fact that the options strike prices are either the same, or closer to each other. On the other hand, the *long strangle* and *short condor*, have a lower potential loss, leading to a harder strategy decision. Essentially, on a *long strangle* and a *short condor* with calls or puts, the farther the strike prices are from each other, the lower the potential loss, and the bigger the movement would need to be to achieve the break-even point.

Owing to data restrictions, it will be tested only three of the strategies mentioned above: *long straddle, long strangle and short butterfly with calls*. The *short condor with calls/puts* will not be used, due to the impossibility to obtain the necessary data.

3.2 Assets selection

As the main purpose of the present study is to test the profitability of high volatility expectation trades with option contracts, for obvious reasons, the data subject to research are **option contracts**.

After choosing the strategies of research, one had to identify, a general way to test the volatility in the market, for each specific event. In chapter 2.3 (2.3 Economic and Political Events), it has been described the motivations and implications of each political event, as well as the assets which would mostly perform the volatility in the market. When choosing the assets of study, one should consider the underlying assets mentioned in chapter 2.1.2.: options on stocks, options on stock indices, options on currencies and options on futures. As the intention is to track the movement of the market as a whole, this study focuses on the effects of the events on stock indices.

In order to test the strategies on the equity market, index options were chosen in detriment of single stocks. The equity indices path the movement/reaction of the bigger/most representative stocks for each market, without being affected by specific events of the single stocks.

Thus, for each event one will observe the performance of a set of different options on indices. Also, for each underlying asset, there will be options on different maturities and strike prices.

3.2.1 United Kingdom Referendum

Facing the possibility of an abandonment of the United Kingdom of the European Union (typically called ‘Brexit’), and considering all the risks that it would bring (discussed in chapter 2.3.1), most of them unknown, the investors were expecting high levels of volatility, mainly related to the uncertainty that a possible ‘Brexit’ could produce. Thus, it seemed clear that the benchmark index in the United Kingdom, the Footsie 100, was the asset that would better reflect the movement of the Britain market as a whole.

The Footsie 100 (FTSE 100) is calculated by the FTSE The Index Company, which is an independent jointly-owned company of the Financial Times and the London Stock Exchange. It represents a pool of 100 stocks representative of the London Stock Exchange, aiming to detect movements of high or low on the prices. Throughout the use of the British Index, one could dissipate the specific risk that one might find for instance in single stocks.

In addition, this event also brought risks across Europe, jeopardizing the European project itself. Therefore, besides the Footsie 100, one decided to apply the same strategies to the a different European index, once it would also be expected to observe high levels of volatility in the rest of Europe, due to all the underlying uncertainty.

Being Germany the largest European economy (3.47 trillion GDP; see chapter 2.3.1) it is the one that would better reflect the impact of the event on the rest of Europe. Moreover, the German DAX 30 (DAX 30) is the main European reference index, representing the 30 largest and most liquid German open companies that trade on the Frankfurt Stock Exchange.

Thus, in order to test the strategies on the United Kingdom Referendum event, the indices chosen have been the Footsie 100 and the German DAX 30.

3.2.2 United States presidential elections

As discussed in chapter 2.3.2, the United States Elections were an event of extra expected volatility, due to the possibility of the election of Donald Trump, which was the scenario of higher risk, in the market view. For that reason, the market was expecting high levels of volatility, both in anticipation of the decision and after the disclosure of the results.

Similarly to the United Kingdom Referendum, the chosen index to test the strategies is the benchmark index in the United States stock exchange, and in this case, also the main reference index worldwide: the Standard & Poor's 500 Index (S&P 500).

The S&P 500 is an index of 500 stocks, which is seen as a leading indicator of U.S. equities and a reflection of the performance of the large cap universe. There are other S&P indexes, a small cap index, including small cap companies and a middle cap index, including mid cap companies. The S&P 500 is considered representative of the market,

as it includes a significant portion of the total value of the market. The 500 companies included in the index, are selected by the S&P Index Committee. The S&P 500 became perceived as the more representative of the market, unseating the Dow Jones Industrial Average (DJIA), because it is made of 500 companies, compared to 30, and it uses a market cap methodology, giving a higher weighing to larger companies.

For that reason, the present study will apply the high volatility expectation strategies to options on the S&P 500 index. Again, through the use of the index, one dissipates the specific risks of the single stocks.

The following table summarizes the chosen options for each event:

Event/Underlying Asset	Index*
U.K. Referendum	German DAX 30 Footsie 100
USA Elections	S&P500

* Index option

Table 2: Assets selection

3.3 Methodology

In the present thesis, one proposes to prove the possibility of obtaining a positive result on some specific events, when using high volatility expectation trades with options. The methodology used to test if the strategies with options result on a positive or negative payoff on the chosen events is the back-testing methodology.

Back-testing is the method of testing a trading strategy on past data to confirm its viability, before a trader or investor risks any capital. Thus, one had to assemble the data of both events of 2016.

The strategies will be modeled using for this purpose equity index options. However, before performing the speculation strategies, there are a lot of rules and assumptions that need to be established first.

3.3.1 Expiration dates

As a starting point one had to identify the effective dates on which the events took place:

- ‘Brexit’: June 23rd, 2016, wherein the decision had effects on the market during the dawn of June 24th, which was the last Friday of the expiration month.
- USA elections: November 8th, 2016, wherein the decision had effects on the market during the dawn of November 9th, which was the second Wednesday of the expiration month.

As discussed in chapter 2.1.2, option’s expirations follow their own rules, where options on indices generally expire on the third Friday of the expiration month. Once the above mentioned dates do not overlap with the exact option’s expiration dates, one had to pick the expiration dates that would better reflect the volatility in the market. The period where one could identify higher levels of volatility were the days before and after the event. For that reason one picked options that would expire just before and right after the event occurrence.

For the ‘Brexit’, one chose the options expiring just before and right after June 24th. Since the strategies applied are only on index options (German DAX 30 and Footsie 100) the expiration dates of the options result on June 17th and July 15th as these are the third Fridays of the expiration months.

Accordingly, for the second event, the volatility of the index S&P 500 will be tested. For the S&P500, the expiration dates followed the same rule: choosing options expiring before and after the event, which resulted on October 21st and November 18th. However, once November 18th is very close to the event’s date, it was added a third option, expiring around one month after the event, resulting on December 16th.

The tables below summarize all the options that will be object of study:

U.K. Referendum	Before the event	After the event
German DAX 30	DAX 06/17/16 C K	DAX 07/15/16 C K
	DAX 06/17/16 P K	DAX 07/15/16 P K
Footsie 100	UKX 06/17/16 C K	DAX 07/15/16 C K
	UKX 06/17/16 P K	DAX 07/15/16 P K

Table 3: Options under study – ‘Brexit’

U.S. Elections	Before the event	After the event	After the event
S&P 500	SPX US 10/21/16 C K	SPX US 11/18/16 C K	SPX US 12/16/16 C K
	SPX US 10/21/16 P K	SPX US 11/18/16 P K	SPX US 12/16/16 P K

Table 4: Options under study – US presidential elections

To sum up, there are eight options combinations for ‘Brexit’ and six for USA Elections; however we end up with a much higher number of tests, due to the different buy dates that will be assumed.

3.3.2 Buying dates

When applying the back-testing, it is necessary to pre-define what the date of initiation of the strategies is. The strategies start on the dates the options are bought. The buy date has a significant impact on the result of the strategy, since this is the starting point to define the strike price of each option. Also the price that one pays for the option depends on when the options are purchased.

The clearer the investor's expectations of the direction a particular asset can take, the more the price of the respective call / put will tend to rise. Likewise, when it gets clear to the investors that a certain event might cause volatility in the market, that expectation will get reflected in the price of the options. Thus, the price of the options is positively correlated with the expectation level of volatility in the market.

The main portion of tests is focused on options with a buy date about a month before their expiration, until the maturity date of the option. Therefore we ended up with 20-22 results per strategy and per expiration date. However, one considered relevant to test the results with buy dates three and six month before the expiration date.

Taking into account its political and macroeconomic impact, both events have been anticipated in advance, whereby it makes sense to test the strategies also some months before.

3.3.3 Assumptions: strike prices and option prices

Since the strategies application is based on the back-testing model, all the parameters that constitute the strategies, have to be defined *a posteriori*. For that reason, the quotes of the underlying assets that establish the strategies have to be object of some assumptions.

When building the strategies with options, on the first place, one have to take into account the price of the underlying asset on the date of purchase of the option, since this is the starting point to choose the strike prices of the options. Therefore, the strike prices have been defined based on the closing price of the underlying assets on the date of initiation of the strategy.

To illustrate, consider the following example of a long straddle strategy, on the German DAX 30:

- Buy on 20th June 2016, an ATM call option and an ATM put option, with the same expiry date (July 15th, 2016);
- In order to choose the strike prices of both options (call and put) one assumed the closing price of DAX 30 on the date of purchase of the options (June 20th, 2016): DAX closed at 9.962;
- Since the strike prices on index options mostly work with round numbers (rounded up to 50), the ATM call/put option bought on the 20th June, had a strike price of 9.950.

When talking about long strangle and short butterfly spread with calls, these strategies are built with ITM and OTM options. For that reason, besides assuming the price at close of the underlying asset, one had to choose the striking prices for the options, and consequently define the percentage of difference between the strike prices of the ITM and OTM options, and the spot price.

For the indices Footsie 100 and German DAX 30, it has been chose call and put options that are at least 5% out/in the money for the long strangle, and 6% for the short butterfly spread. This means that the ITM and OTM options were 5%/6% distant from the closing price of the mentioned assets, at the date in which the option strategies were initiated. For the S&P500, one defined a distance of 3% for the long strangle options, and 4% for the short butterfly spreads. The percentage difference is smaller for the S&P 500 since this is a much less volatile index, when comparing to DAX 30 and FTSE 100. When no option was at least 5%/6% or 3%/4% out/in the money, it has been used whichever option was closest to being 5%/6% or 3%/4% out/in the money.

Additionally, when it comes to the price of the options, once the data *a posteriori* is limited, it had to be assumed the price at close as the price paid for the options. This

assumption means that we are considering that the strategy was always built at the last trade of the day. The price of the options is based on bid-ask midpoint, due to limitations of exporting the ask/bid price individually.

All price data used has been exported from the *Bloomberg* platform, at *BiG – Banco de Investimento Global*.

3.4 Results

As mentioned in the introduction, the aim of the thesis is to prove the possibility of obtaining a positive result on certain events, when using high volatility expectation trades with options. The present section focuses on the presentation of the results obtained by the application of the different strategies selected in chapter 3.1. Additionally, for each strategy, it will be analyzed what are the maturities and assets that achieved a better result and for what reason.

The strategies have been applied on both events described in chapter 2.3. Each event comprises different risks and had a differentiated impact on the market, whereby the analysis of the results will be segregated per event.

For each combination of options tested, there are multiple corresponding buy dates. For that reason, our study does not end up with a single result, but with multiple different results, which makes the analysis much more complex. For the United Kingdom referendum event, the three strategies sum the total of 238 trades tested. While for the United States elections 169 trades for all three strategies have been tested which results in a total of 407 trades on both events.

Before going through the results, it is essential to understand what was the measure used to evaluate the outcomes. Here it can be defined two ways to evaluate the results obtained: 1) through the number of positive/negative results obtained on each strategy; and 2) through the aggregate payoff obtained on each strategy. Considering the analysis through the number of positive/negative results obtained, these might be less relevant, once you might obtain many positive/negative results, although with no monetary expression.

Thus, the metric defined to evaluate the performance of the strategies is the **added value** (below referred as Σ). The added value is the sum of all results obtained per

expiration date and per asset. When the added value is positive, it means that the sum of all positive lines for a certain strategy on a certain asset and expiry date is greater than the sum of all negative lines. This means that, for the selected buying dates, if an investor builds the same strategy every day, he would get a positive result.

3.4.1 ‘Brexit’ – Results exposition and analysis

When applying the strategies on the ‘Brexit’ event, one defined two different expiry dates for each strategy and asset tested: one before the occurrence of the event, and one after. Since the strategies are testing on two different indices, it ends up with four groups of results.

The present chapter will describe the results per maturity and asset. The following tables present the results obtained on each strategy.

Long straddle

LONG STRADDLE	Options on 17-06-2016	Options on 15-07-2016
Footsie 100	- 21 tests applied; - 7 positive results: € 448; - 14 negative results: - € 2.108; $\sum - € 1.660$	- 22 tests applied; - 5 positive results: € 683; - 17 negative results: - € 1.702. $\sum - € 1.020$
German DAX 30	- 22 tests applied; - 12 positive results: € 3.265; - 10 negative results: - € 2.109. $\sum € 1.156$	- 22 tests applied; - 8 positive results: € 1.419. - 14 negative results: - € 4.314; $\sum - € 2.895$

Table 5: Long straddle results - ‘Brexit’

While analyzing the results obtained by the application of the long straddle on the event of the United Kingdom Referendum, it can be concluded that it would get a positive result in only one of the four tested options. For Footsie 100, the long straddle did not achieve a positive result, in any of the maturities. On the other hand, for the DAX 30, one would get a positive result on the option maturing before the event occurred, and a negative result on the option maturing after the event.

When looking at the four results on the long straddle, one can see that the German DAX entails the best and the worst performed strategy, where the best performed is that with options expiring before the event, and the worst is the one with options expiring after the event. Contrarily, regarding the FTSE 100 the options expiring after the event performed better when comparing with the options expiring before the event.

Long strangle

LONG STRANGLE	Options on 17-06-2016	Options on 15-07-2016
Footsie 100	- 19 tests applied; - 0 positive results; - 19 negative results; $\sum - \text{€ } 2.062$	- 18 tests applied; - 4 positive results: € 623; - 14 results: - € 788; $\sum - \text{€ } 165$
German DAX 30	- 22 tests applied; - 8 positive results: € 646; - 14 negative results: - € 1.331; $\sum - \text{€ } 685$	- 21 tests applied; - 4 positive results: € 537; - 17 negative results: - € 2.983; $\sum - \text{€ } 2.445$

Table 6: Long strangle results - ‘Brexit’

Concerning the results obtained on the long strangle, it ends up with a negative result for all the added values in every maturity for both indices. Similarly to the long straddle, the strategies with options on the DAX 30 are both, the worst and the best performed, being the strategy with options expiring after the event the worst performed. Again, when looking at the results of the FTSE 100 individually, one can see that the options expiring before the event had a worst performance.

Short butterfly spread with calls

S. BUTTERFLY SPREAD W/ CALLS	Options on 17-06-2016	Options on 15-07-2016
Footsie 100	- 14 tests applied; - 12 positive results: € 1.525; - 2 negative results: - € 189; $\sum \text{€ } 1336$	- 15 tests applied; - 14 positive results: € 1.875; - 1 negative result: - € 1,5; $\sum \text{€ } 1.874$

German DAX 30	- 22 tests applied; - 16 positive results: € 4.539; - 6 negative results: - € 628. ∑ € 3.911	- 21 tests applied; - 15 positive results: €2.136; - 6 negative results: - € 1.743. ∑ € 393
----------------------	--	---

Table 7: Short butterfly spread with calls results - ‘Brexit’

Contrary to the two previous strategies, the short butterfly spread with calls ended up with a positive result for every asset and maturity, with all added values positive. Here, the best performed strategy is the one with options on the DAX 30, expiring before the event occurrence, while the worst performed is that on the DAX 30, whose options expire after the event. Lastly, the Footsie 100 had a better performance on the options expiring after the event.

Looking into the results in more detail, one might identify a pattern when comparing the performance between the different options maturities across the strategies. For all three strategies, the German DAX 30 had a better performance on the pre-event strategies. On the other hand, the Footsie 100 performed a better result on the strategies with options expiring after the event.

On a first analysis one conclude that the DAX 30 must have achieved higher levels of volatility before the event, and for FTSE 100 the volatility must have been higher after the event. Nevertheless, the price movement is not the only variable affecting the payoffs of the strategies. Therefore, in order to better understand what were the reasons for the DAX having a best performance on the pre-event and for the FTSE on the post-event, it will next be analyzed the results per underlying asset.

3.4.1.1 German DAX 30 – Analysis of results

With the purpose of identifying the main reasons why the results on the DAX 30 were more profitable on the pre-event than on the post-event, one should first understand what the price movement on that period was. The figure below might help us understanding the effects of the price of the underlying asset on the payoffs obtained.

Testing high volatility expectation trades – 2016 events



Figure 15: German DAX 30 from January 2016 to August 2016

Source: Saxo Bank

Considering only the payoffs between the two expiration dates on the DAX 30, one could assume that the index was more volatile on the anticipation, rather than after the results of the referendum. However the price chart transmits that there was some volatility both before and after the event. Additionally, after calculating the historical volatilities of DAX 30 for the periods tested, one might even conclude that there was more volatility during the period after the event, than before it. The table below summarizes the historical volatilities for DAX on the periods under study:

Historical volatility DAX 30 (21 days)	
From 20-05-16 to 17-06-16	18,79%
From 17-06-16 to 15-07-16	35,82%

Table 8: Historical volatilities on German DAX 30

For instance, from the three weeks before the first expiration date, the DAX 30 devalued about -6.40%. Additionally, one might also see a considerable move in the price of DAX from the day of the event, 24th June, until the second expiration date. That price move comprises an appreciation in the price of DAX of about 5.30%. Comparing both examples, there is a small difference of 1.10% on the price move; however, there is a considerable difference on the payoff of both maturities across the three strategies.

On that point, one can see that the price of the underlying asset is not the only variable that affects the payoff of the strategy. There are several variables that strongly influence the results such as a) the date on which the strategy is built, referred as the buy date; b) the value of the premium paid/received when building the strategies.

Let us consider the examples mentioned earlier. The table below allows us to compare the impacts of the different variables on the payoffs.

DAX 30	Long straddle		Long strangle		Short butterfly spread with calls	
Buy date	27-05-2016	24-06-2016	27-05-2016	24-06-2016	27-05-2016	24-06-2016
Expiry date	17-06-2016	15-07-2016	17-06-2016	15-07-2016	17-06-2016	15-07-2016
Percentage difference between spot prices	-6,40%	5,30%	-6,40%	5,30%	-6,40%	5,30%
Payoff 1	-159,3	183,6	125,2	-146,5	669,8	-304,8
Payoff 2	478,2	-320,0	-15,3	-73,7	9,1	75,9
Payoff 3	-	-	-	-	-318,5	367,2
Net Premium paid/received	-349,7	-653,3	-58,7	-237,1	360,4	171,39
Total Payoff	318,9	-136,4	109,9	-220,2	360,4	138,3

Table 9: Comparison between payoffs of DAX 30 on both maturities, across the three strategies

On the present example, the variable that most affects the payoffs is the total premium paid/received when building the strategy. The value of the premium is always more favorable in the first expiration date, which means that the options expiring after the event seem to be more expensive than the ones expiring before. This is an effect of the expectations of the investors in the market, who expected more volatility after the event, leading to the rise in the prices of the options, what made the post-event strategies being less favorable for DAX 30.

3.4.1.2 Footsie 100 – Analysis of results

As mentioned earlier, on the Footsie 100 it has been observed exactly the opposite pattern: the strategies post-event revealed to be more profitable than the ones before the event. The following chart will help understanding the effects of the price of the underlying asset on the payoffs obtained.

Testing high volatility expectation trades – 2016 events



Figure 16: Footsie 100 from January 2016 to August 2016

Source: Saxo Bank

In contrast to the analysis on the DAX 30, on the price chart of FTSE 100, one might recognize more volatility after the results of the referendum, than before. The chart allows us identifying a significant positive price movement on the days following the ‘Brexit’ announcement. From the 24th June 2016 to the second expiration date on the 15th July 2016, the price appreciated 8.6%, which might be one of the main reasons for the better results on the second expiration, when comparing to the first one. However, it is necessary to calculate the implied volatilities, in order to take any conclusion.

When comparing the historical volatilities for Footsie 100 on both periods tested, one might confirm that there was effectively higher volatility on the second period tested. The table below evidences the historical volatilities for FTSE on both periods.

Historical volatility FTSE 100 (21 days)	
From 20-05-16 to 17-06-16	14,80%
From 17-06-16 to 15-07-16	26,24%

Table 10: Historical volatilities Footsie 100

After confirming the historical volatilities, one will next consider the same example as for the DAX 30, in order to identify if there are additional variables that clearly affected the results.

Testing high volatility expectation trades – 2016 events

FTSE 100	Long straddle		Long strangle		Short butterfly spread with calls	
Buy date	27-05-2016	24-06-2016	27-05-2016	24-06-2016	27-05-2016	24-06-2016
Expiry date	17-06-2016	15-07-2016	17-06-2016	15-07-2016	17-06-2016	15-07-2016
Difference between spot prices in %	-6,40%	5,30%	-6,40%	5,30%	-6,40%	5,30%
Payoff 1	-97,9	314,2	-17,6	-86,7	426,1	-299,6
Payoff 2	121,31	-192,6	-3,7	188,24	0,7	-149,9
Payoff 3	-	-	-	-	-218,0	628,5
Net Premium paid/received	-205,5	-397,6	-21,3	-117,7	379,9	178,9
Total Payoff	23,41	121,6	-21,3	101,54	208,8	178,9

Table 11: Comparison between payoffs of FTSE 100 on both maturities, across the three strategies

The present examples confirm the pattern on both, the long straddle and long strangle: the Footsie 100 performed a better result on the options expiring after the event. Contrarily, on the short butterfly spread with calls there was a higher result on the expiration date before the event, although for a small difference (around 30 points). Regarding the premiums paid/received, one cannot identify a clear impact on the payoffs, since the higher premiums coincide with the higher results.

Thus, on the present example one might consider the price movement as the principal variable affecting the payoff.

3.4.2 US presidential elections – Results exposition and analysis

Regarding the USA Elections, one tested the strategies on options on the S&P 500, for three different expiry dates, one before the occurrence of the event, and 2 maturities after. Since the Election Day is very close to the second maturity, one considered relevant to test the volatility one month after the occurrence.

The results will be described per maturity and asset. The succeeding tables illustrate the mentioned results per strategy.

LONG STRADDLE	Options on 21-10-2016	Options on 18-11-2016	Options on 16-12-2016
S&P 500	- 20 tests applied; - 0 positive results; - 20 negative results: - €	- 20 tests applied; - 4 positive results: € 96; - 16 negative results: - €	- 20 tests applied; - 12 positive results: € 193;

Testing high volatility expectation trades – 2016 events

465; $\sum - \text{€ } 465$	175. $\sum - \text{€ } 79$	- 8 negative results: - € 97. $\sum \text{€ } 96$
--------------------------------	-------------------------------	--

Table 12: Long straddle results – US presidential elections

Starting by the long straddle, the only strategy at which one would get a positive result is the one with options on the last expiration date, which is about a month after the event occurrence. On the other hand, the strategy at which one would get the worst result is the one with options expiring before the event.

LONG STRANGLE	Options on 21-10-2016	Options on 18-11-2016	Options on 16-12-2016
S&P 500	- 21 tests applied; - 0 positive results; - 21 negative results: - € 168; $\sum - \text{€ } 168$	- 21 tests applied; - 2 positive results: € 7; - 19 negative results: - € 218; 225. $\sum - \text{€ } 218$	- 19 tests applied; - 1 positive results: € 1; - 18 negative results: - € 83; 83. $\sum - \text{€ } 83$

Table 13: Long strangle results – US presidential elections

Concerning the long strangle, all the obtained results are negative, wherein the most negative value resulted of the options expiring right after the event. The less negative value is, once again, the one with options on the last expiration date.

S. BUTTERFLY SPREAD W/ CALLS	Options on 21-10-2016	Options on 18-11-2016	Options on 16-12-2016
S&P 500	- 15 tests applied; - 1 positive results €1; - 14 negative results: - € 266; 267; $\sum - \text{€ } 266$	- 16 tests applied; - 7 positive results: € 141; - 9 negative results: - € 60. $\sum \text{€ } 81$	- 17 tests applied; - 12 positive results: € 256; - 5 negative results: - € 69. $\sum \text{€ } 186$

Table 14: Short butterfly spread with calls results – US presidential elections

Regarding the short butterfly spread with calls, one would get a positive result on both strategies whose options expire after the event. The strategy with options expiring before the event is, similarly to the long straddle, the worst performed.

Looking at the different maturities for each strategy, the options on the last expiration date, are transversely the better performed. Regarding the remaining two maturities, one cannot identify a pattern, however, on two-thirds of the whole results, the options expiring before the event had a weaker performance, when comparing to the other two.

On a first approach based on the results across the three different maturities, one would infer that there was a higher volatility on the period of the last expiration date, than on the first two, since it achieved the best result on all three strategies. Therefore, with the aim of clarifying the main reasons why the results on the S&P 500 were more profitable on both last expiration dates, and especially on the last one, one should first understand what the price movement on that period was. The following price chart will help understanding the price movement of the underlying asset.

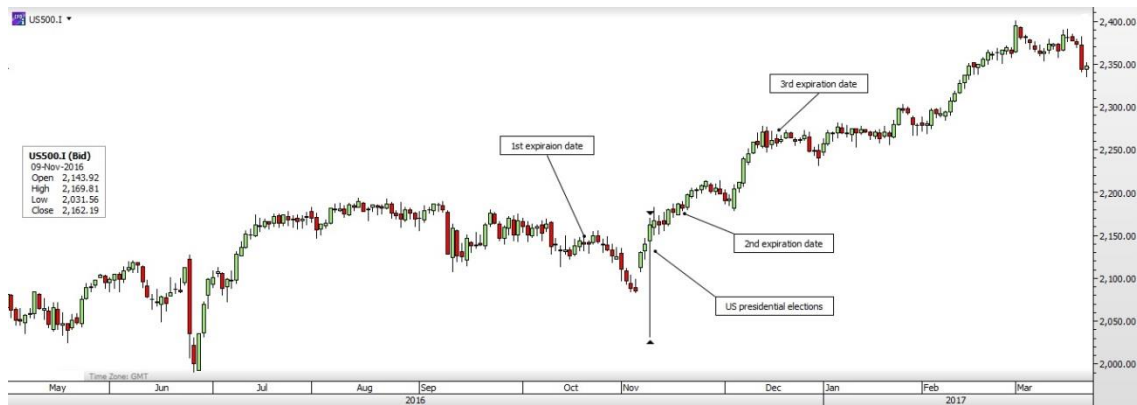

Figure 17: S&P 500 Index from May 2016 to March 2017

Source: Saxo Bank

In the view of the price chart, one would tendentially infer a higher volatility for both last maturities, due to the fact that one identifies a significant rise on the price of the underlying asset following the US presidential elections. Though one cannot take a conclusion about the volatility only based on the price chart. Again, one needs to calculate the historical volatilities on the three different periods.

Historical volatility S&P 500 (21 days)	
From 23-09-16 to 21-10-16	8,66%
From 21-10-16 to 18-11-16	10,43%
From 18-11-16 to 16-12-16	7,73%

Table 15: Historical volatilities on S&P 500

Contrarily, after calculating the historical volatilities, one can conclude that the best performance of the last expiration date is not due to the volatility, since the last period is

the one with the lowest historical volatility. Thereby, there have to be additional variables conducting to the best performance on those maturities.

Additionally, the short butterfly spread with calls proved to be the strategy with the best performance, similarly to 'Brexit', ending up with two positive results. Likewise, the long straddle, compared to the long strangle, had a better result.

3.5 Limitations

While elaborating the present work, some limitations have been found, regarding the application of the tests as well as the conclusions that those tests allowed to take.

Firstly, one identified the limitations regarding the underlying assets available to apply the different tests. On section 2.3 it has been mentioned the assets which were most expected to be affected after the great decisions on the 23rd June and 8th November. The foreign currency market, namely the U.S. Dollar index and the British pound, have been recognized as one of the potentially most affected assets on the financial markets. Despite one identified those affecting factors, these could not have been considered on the present study, due to data exportation restrictions.

This type of limitation may have significantly conditioned the results of the application of the tests, since these assets have been strongly affected by the described events, with special focus on the British Pound currency. If one had tested the application of the strategies on those assets, it might have positively contributed to the results obtained. Therefore, the **available assets** were considered as the first limitation of the present work.

Secondly, when building the strategies, one had to define on which dates to buy the options which automatically reduces the data under study. Thus, the **buying dates** have been considered as the second limitation of the thesis.

Additionally, due to the choice of using index options, one had to work with European options. Since the European options allow the exercise only at maturity, the early exercise had to be ignored. Consequently, the exercise of the options could not be adjusted to match the date of the events. In this case the strategies have been limited to the **expiry dates** of the European index options.

Furthermore, given the fact that the tests have been applied posteriorly to the occurrence of the events, and being the data at that time limited, it had to be assumed the closing price of the options, as the price paid for each call/put option. Accordingly, the assumption of the **closing prices** is considered as a limitation, since one may have been losing more favorable option prices that could have affected the results.

The strategies *long strangle* and *short butterfly spread* are built with ITM and OTM options. However, an ITM/OTM strike price might mean many different distances from the spot price. Therefore, it had to be chosen which strike prices to consider, picking a percentage difference for the spot price. For each strategy that comprised ITM and OTM options, it has been picked a single percentage difference. Once the **strike price** is a variable which has a significant impact on the payoff of each strategy, it has been considered as a limitation to the results of the thesis.

Finally, it should be taken into consideration that this is a back-testing strategy, which does not take into account **complementary analysis**, such as price action analysis and technical analysis, which could support the decision of when to buy a certain strategy. That kind of analysis could help on identifying the best buying moment, which would directly affect the performance of the strategies.

Chapter 4: Conclusion

The present thesis seeks to apply speculation strategies on the political and macroeconomic events which occurred during 2016, through the usage of real options traded on that time. The main goal of the thesis is to prove the possibility of obtaining profit, when using high volatility expectation strategies with option, such as the *long straddle*, *long strangle* and *short butterfly spread with calls*, on the chosen events of 2016. To answer the aforementioned questions, the following possibilities are presented:

Hypotheses I: Achieving a positive result – One could prove the possibility of achieving a positive payoff using high volatility expectation trades.

Hypotheses II: Not achieving a positive result – One could not prove the possibility of achieving a positive payoff using high volatility expectation trades.

Even though the presented results were not globally positive, one has managed to prove that it is possible to achieve a positive payoff when applying high volatility expectation strategies. Each strategy was able to end up with a positive result at some point, although in some cases, only rarely. For that reason one might conclude that the hypotheses that prevails is the hypotheses I.

Nonetheless, the strategies had different results from each other. For instance, when comparing the three strategies with each other, one can perceive that the *short butterfly spread with calls* clearly stands out. It was the only strategy that was able to achieve all added values positive, in the ‘Brexit’ event. It also was the only strategy that ended up with a positive total value for both events. Thus, this strategy revealed to be the most profitable one on the tested events.

For a *short butterfly spread* to be profitable, it is important that the amount of the premium paid for the ATM long calls/puts, be lower than the one received for the ITM and OTM short calls/put. This means that there have to be expectations in the market for the ITM and OTM calls/puts to be successful, which consequently would push the price of the options, up. This kind of expectations work especially well when there are expectations of volatility in the market. This is one of the reasons why the *short butterfly spread with calls* was the most profitable strategy.

On the other hand, the *long strangle* proved to be the less profitable strategy, concluding both events with a negative added value.

The table below summarizes the results per strategy and event.

	Long straddle	Long strangle	Short butterfly spread w/ calls	TOTAL per event
BREXIT	-4.419,00 €	-5.358,00 €	7.513,00 €	-2.264,00 €
US presidential elections	-\$448,00	-\$469,00	\$2,00	-\$915,00

Table 16: Summary of results per strategy and event

Furthermore it could be concluded that the success of the strategies does not only depend on the price action of the underlying asset, namely the price at the maturity of the option. The value of the premium paid/received when building the strategies does also have a great impact on the performance of the strategies. When the expectations of high volatility are highly discounted in the price of the options, it may hamper the profitability of the strategies.

Additionally, it should also be considered the date on which the strategy is initiated. The buying date of the options is extremely important for the performance of the strategies, since this is the starting point for all the remaining variables, such as the strike price and the premium paid/received. The author believes that one could maximize the performance of the strategies tested when complementing with a price action analysis, which would help identifying the best buying moment.

The present thesis is concluded with its goal achieved: it was possible to prove that it would have been possible to achieve profitability applying high volatility expectation strategies during both events.

The preparation of the present thesis, contributed to the understanding of how an investor might apply speculation strategies with options on a real basis.

Bibliography

Hull, J. C. 2008. *Options, Futures, and other derivatives*. Prentice Hall. 8th edition.

Bodie, Z., Kane, A. & Marcus, A., 2003. *Investments*, McGraw Hill, 6th edition

Peixoto, J. P., 2004. *Análise Técnica – Tendências e Formações de Preços*. FUTOP.

Murphy, J. J., 1990. *Technical Analysis of the Financial Markets – A comprehensive guide to trading methods and applications*. New York Institute of Finance

Leland, H. E. and Rubinstein, M., 1976. The Evolution of Portfolio Insurance. *Luskin, D., Dynamic Hedging: A Guide to Portfolio Insurance*.

Bertrand, P. and Prigent, J-L., 2001. Portfolio insurance strategies: OBPI versus CPPI, *University of CERGY Working paper*, 30.

Black, F. and Scholes, M., 1973. The pricing of Options and Corporate Liabilities. *Journal of Political Economy*, 81: 637-659.

Merton, R. C., 1973. Theory of Rational Option Pricing. *Bell Journal of Economics and Management Science*, 4: 141-183.

Perold F. A. and Sharpe W. F., 1988. Dynamic Strategies for Asset Allocation. *Financial Analysts Journal*, 149-160

Appendix 1³

Data collection - United Kingdom Referendum

Long straddle data for calls – DAX index

Buy 1 ATM Call

Buy 1 ATM Put

LONG STRADDLE - Dax index

Buy date	Asset	Maturity date	Call-Put	Strike Price	Spot Price	Option Price	Ticker
17-12-2015	DAX	06-17-16	C	10.750	10.738	741,10	DAX 06/17/16 C10750 Equity
17-03-2016	DAX	06-17-16	C	9.900	9.892	490,97	DAX 06/17/16 C9900 Equity
20-05-2016	DAX	06-17-16	C	9.900	9.916	253,53	DAX 06/17/16 C9900 Equity
23-05-2016	DAX	06-17-16	C	9.850	9.842	240,90	DAX 06/17/16 C9850 Equity
24-05-2016	DAX	06-17-16	C	10.050	10.057	225,43	DAX 06/17/16 C10050 Equity
25-05-2016	DAX	06-17-16	C	10.200	10.205	203,21	DAX 06/17/16 C10200 Equity
26-05-2016	DAX	06-17-16	C	10.250	10.273	207,65	DAX 06/17/16 C10250 Equity
27-05-2016	DAX	06-17-16	C	10.300	10.286	159,26	DAX 06/17/16 C10300 Equity
30-05-2016	DAX	06-17-16	C	10.350	10.333	158,88	DAX 06/17/16 C10350 Equity
31-05-2016	DAX	06-17-16	C	10.250	10.263	176,33	DAX 06/17/16 C10250 Equity
01-06-2016	DAX	06-17-16	C	10.200	10.204	168,62	DAX 06/17/16 C10200 Equity
02-06-2016	DAX	06-17-16	C	10.200	10.208	167,34	DAX 06/17/16 C10200 Equity
03-06-2016	DAX	06-17-16	C	10.100	10.103	145,43	DAX 06/17/16 C10100 Equity
06-06-2016	DAX	06-17-16	C	10.100	10.121	154,97	DAX 06/17/16 C10100 Equity
07-06-2016	DAX	06-17-16	C	10.300	10.288	112,13	DAX 06/17/16 C10300 Equity
08-06-2016	DAX	06-17-16	C	10.200	10.217	114,79	DAX 06/17/16 C10200 Equity
09-06-2016	DAX	06-17-16	C	10.100	10.089	99,72	DAX 06/17/16 C10100 Equity
10-06-2016	DAX	06-17-16	C	9.850	9.835	124,51	DAX 06/17/16 C9850 Equity
13-06-2016	DAX	06-17-16	C	9.650	9.657	150,98	DAX 06/17/16 C9650 Equity
14-06-2016	DAX	06-17-16	C	9.500	9.519	138,14	DAX 06/17/16 C9500 Equity
15-06-2016	DAX	06-17-16	C	9.600	9.607	108,00	DAX 06/17/16 C9600 Equity
16-06-2016	DAX	06-17-16	C	9.550	9.550	62,42	DAX 06/17/16 C9550 Equity
17-06-2016	DAX	06-17-16	C	9.650	9.631	0,01	DAX 06/17/16 C9650 Equity
18-01-2016	DAX	07-15-16	C	9.500	9.522	-	DAX 07/15/16 C9500 Equity
18-04-2016	DAX	07-15-16	C	10.100	10.120	524,91	DAX 07/15/16 C10100 Equity
17-06-2016	DAX	07-15-16	C	9.650	9.631	385,33	DAX 07/15/16 C9650 Equity
20-06-2016	DAX	07-15-16	C	9.950	9.962	368,42	DAX 07/15/16 C9950 Equity
21-06-2016	DAX	07-15-16	C	10.000	10.016	385,40	DAX 07/15/16 C10000 Equity
22-06-2016	DAX	07-15-16	C	10.050	10.071	448,16	DAX 07/15/16 C10050 Equity
23-06-2016	DAX	07-15-16	C	10.250	10.257	330,26	DAX 07/15/16 C10250 Equity
24-06-2016	DAX	07-15-16	C	9.550	9.557	333,31	DAX 07/15/16 C9550 Equity
27-06-2016	DAX	07-15-16	C	9.250	9.269	303,54	DAX 07/15/16 C9250 Equity
28-06-2016	DAX	07-15-16	C	9.450	9.447	241,18	DAX 07/15/16 C9450 Equity
29-06-2016	DAX	07-15-16	C	9.600	9.612	236,05	DAX 07/15/16 C9600 Equity
30-06-2016	DAX	07-15-16	C	9.700	9.680	190,12	DAX 07/15/16 C9700 Equity
01-07-2016	DAX	07-15-16	C	9.800	9.776	163,71	DAX 07/15/16 C9800 Equity
04-07-2016	DAX	07-15-16	C	9.700	9.709	180,04	DAX 07/15/16 C9700 Equity
05-07-2016	DAX	07-15-16	C	9.550	9.533	162,58	DAX 07/15/16 C9550 Equity
06-07-2016	DAX	07-15-16	C	9.350	9.373	189,07	DAX 07/15/16 C9350 Equity
07-07-2016	DAX	07-15-16	C	9.400	9.419	164,85	DAX 07/15/16 C9400 Equity
08-07-2016	DAX	07-15-16	C	9.650	9.630	114,64	DAX 07/15/16 C9650 Equity
11-07-2016	DAX	07-15-16	C	9.850	9.833	92,85	DAX 07/15/16 C9850 Equity
12-07-2016	DAX	07-15-16	C	9.950	9.964	97,39	DAX 07/15/16 C9950 Equity
13-07-2016	DAX	07-15-16	C	9.950	9.931	69,99	DAX 07/15/16 C9950 Equity
14-07-2016	DAX	07-15-16	C	10.050	10.068	54,68	DAX 07/15/16 C10050 Equity
15-07-2016	DAX	07-15-16	C	10.050	10.067	0,01	DAX 07/15/16 C10050 Equity

³ All the data regarding the option prices and index prices, was exported from *Bloomberg*

Testing high volatility expectation trades – 2016 events

Long straddle data for puts – DAX index

LONG STRADDLE - Dax index

Buy date	Asset	Maturity date	Call-Put	Strike Price	Spot Price	Option Price	Ticker
17-12-2015	DAX	06-17-16	P	10.750	10.738	691,23	DAX 06/17/16 P10750 Equity
17-03-2016	DAX	06-17-16	P	9.900	9.892	482,71	DAX 06/17/16 P9900 Equity
20-05-2016	DAX	06-17-16	P	9.900	9.916	242,87	DAX 06/17/16 P9900 Equity
23-05-2016	DAX	06-17-16	P	9.850	9.842	231,93	DAX 06/17/16 P9850 Equity
24-05-2016	DAX	06-17-16	P	10.050	10.057	201,46	DAX 06/17/16 P10050 Equity
25-05-2016	DAX	06-17-16	P	10.200	10.205	195,39	DAX 06/17/16 P10200 Equity
26-05-2016	DAX	06-17-16	P	10.250	10.273	177,47	DAX 06/17/16 P10250 Equity
27-05-2016	DAX	06-17-16	P	10.300	10.286	190,44	DAX 06/17/16 P10300 Equity
30-05-2016	DAX	06-17-16	P	10.350	10.333	173,91	DAX 06/17/16 P10350 Equity
31-05-2016	DAX	06-17-16	P	10.250	10.263	161,29	DAX 06/17/16 P10250 Equity
01-06-2016	DAX	06-17-16	P	10.200	10.204	174,20	DAX 06/17/16 P10200 Equity
02-06-2016	DAX	06-17-16	P	10.200	10.208	145,03	DAX 06/17/16 P10200 Equity
03-06-2016	DAX	06-17-16	P	10.100	10.103	156,19	DAX 06/17/16 P10100 Equity
06-06-2016	DAX	06-17-16	P	10.100	10.121	117,99	DAX 06/17/16 P10100 Equity
07-06-2016	DAX	06-17-16	P	10.300	10.288	125,18	DAX 06/17/16 P10300 Equity
08-06-2016	DAX	06-17-16	P	10.200	10.217	109,09	DAX 06/17/16 P10200 Equity
09-06-2016	DAX	06-17-16	P	10.100	10.089	114,44	DAX 06/17/16 P10100 Equity
10-06-2016	DAX	06-17-16	P	9.850	9.835	140,3	DAX 06/17/16 P9850 Equity
13-06-2016	DAX	06-17-16	P	9.650	9.657	112,61	DAX 06/17/16 P9650 Equity
14-06-2016	DAX	06-17-16	P	9.500	9.519	124,13	DAX 06/17/16 P9500 Equity
15-06-2016	DAX	06-17-16	P	9.600	9.607	79,34	DAX 06/17/16 P9600 Equity
16-06-2016	DAX	06-17-16	P	9.550	9.550	41,13	DAX 06/17/16 P9550 Equity
17-06-2016	DAX	06-17-16	P	9.650	9.631	20,37	DAX 06/17/16 P9650 Equity
18-01-2016	DAX	07-15-16	P	9.500	9.522	-	DAX 07/15/16 P9500 Equity
18-04-2016	DAX	07-15-16	P	10.100	10.120	455,72	DAX 07/15/16 P10100 Equity
17-06-2016	DAX	07-15-16	P	9.650	9.631	430,96	DAX 07/15/16 P9650 Equity
20-06-2016	DAX	07-15-16	P	9.950	9.962	358,46	DAX 07/15/16 P9950 Equity
21-06-2016	DAX	07-15-16	P	10.000	10.016	344,08	DAX 07/15/16 P10000 Equity
22-06-2016	DAX	07-15-16	P	10.050	10.071	351,75	DAX 07/15/16 P10050 Equity
23-06-2016	DAX	07-15-16	P	10.250	10.257	340,48	DAX 07/15/16 P10250 Equity
24-06-2016	DAX	07-15-16	P	9.550	9.557	320,02	DAX 07/15/16 P9550 Equity
27-06-2016	DAX	07-15-16	P	9.250	9.269	288,97	DAX 07/15/16 P9250 Equity
28-06-2016	DAX	07-15-16	P	9.450	9.447	269,14	DAX 07/15/16 P9450 Equity
29-06-2016	DAX	07-15-16	P	9.600	9.612	238,61	DAX 07/15/16 P9600 Equity
30-06-2016	DAX	07-15-16	P	9.700	9.680	213,6	DAX 07/15/16 P9700 Equity
01-07-2016	DAX	07-15-16	P	9.800	9.776	200,69	DAX 07/15/16 P9800 Equity
04-07-2016	DAX	07-15-16	P	9.700	9.709	164,77	DAX 07/15/16 P9700 Equity
05-07-2016	DAX	07-15-16	P	9.550	9.533	187,75	DAX 07/15/16 P9550 Equity
06-07-2016	DAX	07-15-16	P	9.350	9.373	171,1	DAX 07/15/16 P9350 Equity
07-07-2016	DAX	07-15-16	P	9.400	9.419	142,06	DAX 07/15/16 P9400 Equity
08-07-2016	DAX	07-15-16	P	9.650	9.630	129,9	DAX 07/15/16 P9650 Equity
11-07-2016	DAX	07-15-16	P	9.850	9.833	113,4	DAX 07/15/16 P9850 Equity
12-07-2016	DAX	07-15-16	P	9.950	9.964	71,99	DAX 07/15/16 P9950 Equity
13-07-2016	DAX	07-15-16	P	9.950	9.931	69,43	DAX 07/15/16 P9950 Equity
14-07-2016	DAX	07-15-16	P	10.050	10.068	32,67	DAX 07/15/16 P10050 Equity
15-07-2016	DAX	07-15-16	P	10.050	10.067	69,33	DAX 07/15/16 P10050 Equity

Testing high volatility expectation trades – 2016 events

Long straddle data for calls – FTSE index

Buy 1 ATM Call

Buy 1 ATM Put

LONG STRADDLE - FTSE index

Buy date	Asset	Maturity date	Call-Put	Strike Price	Spot Price	Option Price	Ticker
17-12-2015	UKX	06-17-16	C	6.100	6.103	382	UKX 06/17/16 C6100 Equity
17-03-2016	UKX	06-17-16	C	6.200	6.201	230,9	UKX 06/17/16 C6200 Equity
20-05-2016	UKX	06-17-16	C	6.150	6.156	137,9	UKX 06/17/16 C6150 Equity
23-05-2016	UKX	06-17-16	C	6.150	6.136	127,5	UKX 06/17/16 C6150 Equity
24-05-2016	UKX	06-17-16	C	6.200	6.219	144,8	UKX 06/17/16 C6200 Equity
25-05-2016	UKX	06-17-16	C	6.250	6.263	124,1	UKX 06/17/16 C6250 Equity
26-05-2016	UKX	06-17-16	C	6.250	6.266	121,6	UKX 06/17/16 C6250 Equity
27-05-2016	UKX	06-17-16	C	6.250	6.271	97,9	UKX 06/17/16 C6250 Equity
31-05-2016	UKX	06-17-16	C	6.250	6.231	78,2	UKX 06/17/16 C6250 Equity
01-06-2016	UKX	06-17-16	C	6.200	6.192	89,4	UKX 06/17/16 C6200 Equity
02-06-2016	UKX	06-17-16	C	6.200	6.186	90,9	UKX 06/17/16 C6200 Equity
03-06-2016	UKX	06-17-16	C	6.200	6.210	94,4	UKX 06/17/16 C6200 Equity
06-06-2016	UKX	06-17-16	C	6.250	6.273	96,6	UKX 06/17/16 C6250 Equity
07-06-2016	UKX	06-17-16	C	6.300	6.285	57,5	UKX 06/17/16 C6300 Equity
08-06-2016	UKX	06-17-16	C	6.300	6.302	65,4	UKX 06/17/16 C6300 Equity
09-06-2016	UKX	06-17-16	C	6.250	6.232	52,4	UKX 06/17/16 C6250 Equity
10-06-2016	UKX	06-17-16	C	6.100	6.116	114	UKX 06/17/16 C6100 Equity
13-06-2016	UKX	06-17-16	C	6.050	6.045	94,6	UKX 06/17/16 C6050 Equity
14-06-2016	UKX	06-17-16	C	5.900	5.924	104,7	UKX 06/17/16 C5900 Equity
15-06-2016	UKX	06-17-16	C	5.950	5.967	87,8	UKX 06/17/16 C5950 Equity
16-06-2016	UKX	06-17-16	C	5.950	5.950	43,2	UKX 06/17/16 C5950 Equity
17-06-2016	UKX	06-17-16	C	6.000	6.021	63,7	UKX 06/17/16 C6000 Equity
18-01-2016	UKX	07-15-16	C	5.800	5.780	392,2	UKX 07/15/16 C5800 Equity
18-04-2016	UKX	07-15-16	C	6.350	6.354	287	UKX 07/15/16 C6350 Equity
17-06-2016	UKX	07-15-16	C	6.000	6.021	284,1	UKX 07/15/16 C6000 Equity
20-06-2016	UKX	07-15-16	C	6.200	6.204	256,9	UKX 07/15/16 C6200 Equity
21-06-2016	UKX	07-15-16	C	6.250	6.227	251,5	UKX 07/15/16 C6250 Equity
22-06-2016	UKX	07-15-16	C	6.250	6.261	315,4	UKX 07/15/16 C6250 Equity
23-06-2016	UKX	07-15-16	C	6.350	6.338	222,9	UKX 07/15/16 C6350 Equity
24-06-2016	UKX	07-15-16	C	6.150	6.139	205	UKX 07/15/16 C6150 Equity
27-06-2016	UKX	07-15-16	C	6.000	5.982	187,6	UKX 07/15/16 C6000 Equity
28-06-2016	UKX	07-15-16	C	6.150	6.140	150,6	UKX 07/15/16 C6150 Equity
29-06-2016	UKX	07-15-16	C	6.350	6.360	148,9	UKX 07/15/16 C6350 Equity
30-06-2016	UKX	07-15-16	C	6.500	6.504	112,1	UKX 07/15/16 C6500 Equity
01-07-2016	UKX	07-15-16	C	6.600	6.578	99	UKX 07/15/16 C6600 Equity
04-07-2016	UKX	07-15-16	C	6.500	6.522	130,3	UKX 07/15/16 C6500 Equity
05-07-2016	UKX	07-15-16	C	6.550	6.545	107	UKX 07/15/16 C6550 Equity
06-07-2016	UKX	07-15-16	C	6.450	6.464	126,2	UKX 07/15/16 C6450 Equity
07-07-2016	UKX	07-15-16	C	6.550	6.534	89,7	UKX 07/15/16 C6550 Equity
08-07-2016	UKX	07-15-16	C	6.600	6.591	69,4	UKX 07/15/16 C6600 Equity
11-07-2016	UKX	07-15-16	C	6.700	6.683	54,5	UKX 07/15/16 C6700 Equity
12-07-2016	UKX	07-15-16	C	6.700	6.681	49,1	UKX 07/15/16 C6700 Equity
13-07-2016	UKX	07-15-16	C	6.650	6.670	95,6	UKX 07/15/16 C6650 Equity
14-07-2016	UKX	07-15-16	C	6.650	6.654	48	UKX 07/15/16 C6650 Equity
15-07-2016	UKX	07-15-16	C	6.650	6.669	0	UKX 07/15/16 C6650 Equity

Testing high volatility expectation trades – 2016 events

Long straddle data for puts – FTSE index

LONG STRADDLE - FTSE index

Buy date	Asset	Maturity date	Call-Put	Strike Price	Spot Price	Option Price	Ticker
17-12-2015	UKX	06-17-16	P	6.100	6.103	508,6	UKX 06/17/16 P6100 Equity
17-03-2016	UKX	06-17-16	P	6.200	6.201	338	UKX 06/17/16 P6200 Equity
20-05-2016	UKX	06-17-16	P	6.150	6.156	159,7	UKX 06/17/16 P6150 Equity
23-05-2016	UKX	06-17-16	P	6.150	6.136	152,8	UKX 06/17/16 P6150 Equity
24-05-2016	UKX	06-17-16	P	6.200	6.219	120,7	UKX 06/17/16 P6200 Equity
25-05-2016	UKX	06-17-16	P	6.250	6.263	121,9	UKX 06/17/16 P6250 Equity
26-05-2016	UKX	06-17-16	P	6.250	6.266	117,2	UKX 06/17/16 P6250 Equity
27-05-2016	UKX	06-17-16	P	6.250	6.271	107,6	UKX 06/17/16 P6250 Equity
31-05-2016	UKX	06-17-16	P	6.250	6.231	131,4	UKX 06/17/16 P6250 Equity
01-06-2016	UKX	06-17-16	P	6.200	6.192	134,1	UKX 06/17/16 P6200 Equity
02-06-2016	UKX	06-17-16	P	6.200	6.186	112,6	UKX 06/17/16 P6200 Equity
03-06-2016	UKX	06-17-16	P	6.200	6.210	101,6	UKX 06/17/16 P6200 Equity
06-06-2016	UKX	06-17-16	P	6.250	6.273	72,3	UKX 06/17/16 P6250 Equity
07-06-2016	UKX	06-17-16	P	6.300	6.285	104	UKX 06/17/16 P6300 Equity
08-06-2016	UKX	06-17-16	P	6.300	6.302	76,3	UKX 06/17/16 P6300 Equity
09-06-2016	UKX	06-17-16	P	6.250	6.232	89,7	UKX 06/17/16 P6250 Equity
10-06-2016	UKX	06-17-16	P	6.100	6.116	85,3	UKX 06/17/16 P6100 Equity
13-06-2016	UKX	06-17-16	P	6.050	6.045	81,1	UKX 06/17/16 P6050 Equity
14-06-2016	UKX	06-17-16	P	5.900	5.924	73,6	UKX 06/17/16 P5900 Equity
15-06-2016	UKX	06-17-16	P	5.950	5.967	45,3	UKX 06/17/16 P5950 Equity
16-06-2016	UKX	06-17-16	P	5.950	5.950	24,1	UKX 06/17/16 P5950 Equity
17-06-2016	UKX	06-17-16	P	6.000	6.021	0	UKX 06/17/16 P6000 Equity
18-01-2016	UKX	07-15-16	P	5.800	5.780	574,8	UKX 07/15/16 P5800 Equity
18-04-2016	UKX	07-15-16	P	6.350	6.354	349,1	UKX 07/15/16 P6350 Equity
17-06-2016	UKX	07-15-16	P	6.000	6.021	277	UKX 07/15/16 P6000 Equity
20-06-2016	UKX	07-15-16	P	6.200	6.204	242,9	UKX 07/15/16 P6200 Equity
21-06-2016	UKX	07-15-16	P	6.250	6.227	253,7	UKX 07/15/16 P6250 Equity
22-06-2016	UKX	07-15-16	P	6.250	6.261	239,7	UKX 07/15/16 P6250 Equity
23-06-2016	UKX	07-15-16	P	6.350	6.338	261,4	UKX 07/15/16 P6350 Equity
24-06-2016	UKX	07-15-16	P	6.150	6.139	192,6	UKX 07/15/16 P6150 Equity
27-06-2016	UKX	07-15-16	P	6.000	5.982	216,7	UKX 07/15/16 P6000 Equity
28-06-2016	UKX	07-15-16	P	6.150	6.140	185,3	UKX 07/15/16 P6150 Equity
29-06-2016	UKX	07-15-16	P	6.350	6.360	165,7	UKX 07/15/16 P6350 Equity
30-06-2016	UKX	07-15-16	P	6.500	6.504	142	UKX 07/15/16 P6500 Equity
01-07-2016	UKX	07-15-16	P	6.600	6.578	124,9	UKX 07/15/16 P6600 Equity
04-07-2016	UKX	07-15-16	P	6.500	6.522	95,1	UKX 07/15/16 P6500 Equity
05-07-2016	UKX	07-15-16	P	6.550	6.545	95,9	UKX 07/15/16 P6550 Equity
06-07-2016	UKX	07-15-16	P	6.450	6.464	99,7	UKX 07/15/16 P6450 Equity
07-07-2016	UKX	07-15-16	P	6.550	6.534	90,3	UKX 07/15/16 P6550 Equity
08-07-2016	UKX	07-15-16	P	6.600	6.591	66,1	UKX 07/15/16 P6600 Equity
11-07-2016	UKX	07-15-16	P	6.700	6.683	73,9	UKX 07/15/16 P6700 Equity
12-07-2016	UKX	07-15-16	P	6.700	6.681	74,4	UKX 07/15/16 P6700 Equity
13-07-2016	UKX	07-15-16	P	6.650	6.670	31,7	UKX 07/15/16 P6650 Equity
14-07-2016	UKX	07-15-16	P	6.650	6.654	30	UKX 07/15/16 P6650 Equity
15-07-2016	UKX	07-15-16	P	6.650	6.669	19,1	UKX 07/15/16 P6650 Equity

Testing high volatility expectation trades – 2016 events

Long strangle data for calls – DAX index

Buy 1 OTM Call K2

Buy 1 ITM Put K1

LONG STRANGLE - Dax index

5,00%

K2

Buy date	Asset	Maturity date	Call/Put	Strike Price	Spot Price	Option Price	Ticker
17-12-2015	DAX	06-17-16	C	11.300	10.738	453,42	DAX 06/17/16 C11300 Equity
17-03-2016	DAX	06-17-16	C	10.400	9.892	225,12	DAX 06/17/16 C10400 Equity
20-05-2016	DAX	06-17-16	C	10.400	9.916	45,75	DAX 06/17/16 C10400 Equity
23-05-2016	DAX	06-17-16	C	10.350	9.842	39,91	DAX 06/17/16 C10350 Equity
24-05-2016	DAX	06-17-16	C	10.550	10.057	30,99	DAX 06/17/16 C10550 Equity
25-05-2016	DAX	06-17-16	C	10.700	10.205	23,55	DAX 06/17/16 C10700 Equity
26-05-2016	DAX	06-17-16	C	10.750	10.273	25,15	DAX 06/17/16 C10750 Equity
27-05-2016	DAX	06-17-16	C	10.800	10.286	15,26	DAX 06/17/16 C10800 Equity
30-05-2016	DAX	06-17-16	C	10.850	10.333	14,03	DAX 06/17/16 C10850 Equity
31-05-2016	DAX	06-17-16	C	10.750	10.263	15,82	DAX 06/17/16 C10750 Equity
01-06-2016	DAX	06-17-16	C	10.700	10.204	13,07	DAX 06/17/16 C10700 Equity
02-06-2016	DAX	06-17-16	C	10.700	10.208	10,49	DAX 06/17/16 C10700 Equity
03-06-2016	DAX	06-17-16	C	10.600	10.103	7,25	DAX 06/17/16 C10600 Equity
06-06-2016	DAX	06-17-16	C	10.600	10.121	6,03	DAX 06/17/16 C10600 Equity
07-06-2016	DAX	06-17-16	C	10.800	10.288	3,75	DAX 06/17/16 C10800 Equity
08-06-2016	DAX	06-17-16	C	10.700	10.217	3,42	DAX 06/17/16 C10700 Equity
09-06-2016	DAX	06-17-16	C	10.600	10.089	2,83	DAX 06/17/16 C10600 Equity
10-06-2016	DAX	06-17-16	C	10.350	9.835	3,5	DAX 06/17/16 C10350 Equity
13-06-2016	DAX	06-17-16	C	10.150	9.657	4,4	DAX 06/17/16 C10150 Equity
14-06-2016	DAX	06-17-16	C	10.000	9.519	4,82	DAX 06/17/16 C10000 Equity
15-06-2016	DAX	06-17-16	C	10.100	9.607	1,01	DAX 06/17/16 C10100 Equity
16-06-2016	DAX	06-17-16	C	10.050	9.550	0,11	DAX 06/17/16 C10050 Equity
17-06-2016	DAX	06-17-16	C	10.150	9.631	0,01	DAX 06/17/16 C10150 Equity
18-01-2016	DAX	07-15-16	C	10.000	9.522	-	DAX 07/15/16 C10000 Equity
18-04-2016	DAX	07-15-16	C	10.600	10.120	594,68	DAX 07/15/16 C10600 Equity
17-06-2016	DAX	07-15-16	C	10.150	9.631	133,96	DAX 07/15/16 C10150 Equity
20-06-2016	DAX	07-15-16	C	10.450	9.962	104,21	DAX 07/15/16 C10450 Equity
21-06-2016	DAX	07-15-16	C	10.500	10.016	104,15	DAX 07/15/16 C10500 Equity
22-06-2016	DAX	07-15-16	C	10.550	10.071	138,91	DAX 07/15/16 C10550 Equity
23-06-2016	DAX	07-15-16	C	10.750	10.257	66,64	DAX 07/15/16 C10750 Equity
24-06-2016	DAX	07-15-16	C	10.050	9.557	90,56	DAX 07/15/16 C10050 Equity
27-06-2016	DAX	07-15-16	C	9.700	9.269	97,58	DAX 07/15/16 C9700 Equity
28-06-2016	DAX	07-15-16	C	9.900	9.447	55,71	DAX 07/15/16 C9900 Equity
29-06-2016	DAX	07-15-16	C	10.100	9.612	39,4	DAX 07/15/16 C10100 Equity
30-06-2016	DAX	07-15-16	C	10.200	9.680	18,16	DAX 07/15/16 C10200 Equity
01-07-2016	DAX	07-15-16	C	10.300	9.776	12,47	DAX 07-15-16 C10300 Equity
04-07-2016	DAX	07-15-16	C	10.200	9.709	10,26	DAX 07-15-16 C10200 Equity
05-07-2016	DAX	07-15-16	C	10.050	9.533	8,21	DAX 07-15-16 C10050 Equity
06-07-2016	DAX	07-15-16	C	9.800	9.373	19,85	DAX 07-15-16 C9800 Equity
07-07-2016	DAX	07-15-16	C	9.850	9.419	11,95	DAX 07-15-16 C9850 Equity
08-07-2016	DAX	07-15-16	C	10.150	9.630	1,88	DAX 07-15-16 C10150 Equity
11-07-2016	DAX	07-15-16	C	10.350	9.833	1,66	DAX 07-15-16 C10350 Equity
12-07-2016	DAX	07-15-16	C	10.450	9.964	2,33	DAX 07-15-16 C10450 Equity
13-07-2016	DAX	07-15-16	C	10.450	9.931	2,22	DAX 07-15-16 C10450 Equity
14-07-2016	DAX	07-15-16	C	10.550	10.068	0,89	DAX 07-15-16 C10550 Equity
15-07-2016	DAX	07-15-16	C	10.550	10.067	0,01	DAX 07-15-16 C10550 Equity

Testing high volatility expectation trades – 2016 events

Long strangle data for puts – DAX index

LONG STRANGLE - Dax index

-5,00%

K1

Buy date	Asset	Maturity date	Call/Put	Strike Price	Spot Price	Option Price	Ticker
17-12-2015	DAX	06-17-16	P	10.200	10.738	465	DAX 06/17/16 P10200 Equity
17-03-2016	DAX	06-17-16	P	9.400	9.892	288,72	DAX 06/17/16 P9400 Equity
20-05-2016	DAX	06-17-16	P	9.400	9.916	82,86	DAX 06/17/16 P9400 Equity
23-05-2016	DAX	06-17-16	P	9.350	9.842	74,21	DAX 06/17/16 P9350 Equity
24-05-2016	DAX	06-17-16	P	9.550	10.057	57,42	DAX 06/17/16 P9550 Equity
25-05-2016	DAX	06-17-16	P	9.700	10.205	53,56	DAX 06/17/16 P9700 Equity
26-05-2016	DAX	06-17-16	P	9.750	10.273	45,26	DAX 06/17/16 P9750 Equity
27-05-2016	DAX	06-17-16	P	9.800	10.286	43,43	DAX 06-17-16 P9800 Equity
30-05-2016	DAX	06-17-16	P	9.850	10.333	35,52	DAX 06-17-16 P9850 Equity
31-05-2016	DAX	06-17-16	P	9.750	10.263	34,53	DAX 06-17-16 P9750 Equity
01-06-2016	DAX	06-17-16	P	9.700	10.204	40,9	DAX 06-17-16 P9700 Equity
02-06-2016	DAX	06-17-16	P	9.700	10.208	29,9	DAX 06-17-16 P9700 Equity
03-06-2016	DAX	06-17-16	P	9.600	10.103	28,99	DAX 06-17-16 P9600 Equity
06-06-2016	DAX	06-17-16	P	9.600	10.121	16,95	DAX 06-17-16 P9600 Equity
07-06-2016	DAX	06-17-16	P	9.800	10.288	12,82	DAX 06-17-16 P9800 Equity
08-06-2016	DAX	06-17-16	P	9.700	10.217	9,69	DAX 06-17-16 P9700 Equity
09-06-2016	DAX	06-17-16	P	9.600	10.089	9,62	DAX 06-17-16 P9600 Equity
10-06-2016	DAX	06-17-16	P	9.350	9.835	16,92	DAX 06-17-16 P9350 Equity
13-06-2016	DAX	06-17-16	P	9.150	9.657	10,95	DAX 06-17-16 P9150 Equity
14-06-2016	DAX	06-17-16	P	9.000	9.519	11,66	DAX 06-17-16 P9000 Equity
15-06-2016	DAX	06-17-16	P	9.100	9.607	2,81	DAX 06-17-16 P9100 Equity
16-06-2016	DAX	06-17-16	P	9.050	9.550	0,34	DAX 06-17-16 P9050 Equity
17-06-2016	DAX	06-17-16	P	9.150	9.631	0,01	DAX 06-17-16 P9150 Equity
18-01-2016	DAX	07-15-16	P	9.000	9.522	-	DAX 07/15/16 P9000 Equity
18-04-2016	DAX	07-15-16	P	9.600	10.120	272,82	DAX 07/15/16 P9600 Equity
17-06-2016	DAX	07-15-16	P	9.150	9.631	229,96	DAX 07/15/16 P9150 Equity
20-06-2016	DAX	07-15-16	P	9.450	9.962	181,61	DAX 07/15/16 P9450 Equity
21-06-2016	DAX	07-15-16	P	9.500	10.016	184,31	DAX 07/15/16 P9500 Equity
22-06-2016	DAX	07-15-16	P	9.550	10.071	196,22	DAX 07/15/16 P9550 Equity
23-06-2016	DAX	07-15-16	P	9.750	10.257	177,79	DAX 07/15/16 P9750 Equity
24-06-2016	DAX	07-15-16	P	9.050	9.557	146,5	DAX 07/15/16 P9050 Equity
27-06-2016	DAX	07-15-16	P	8.800	9.269	123,29	DAX 07/15/16 P8800 Equity
28-06-2016	DAX	07-15-16	P	9.000	9.447	103,35	DAX 07/15/16 P9000 Equity
29-06-2016	DAX	07-15-16	P	9.100	9.612	75,91	DAX 07/15/16 P9100 Equity
30-06-2016	DAX	07-15-16	P	9.200	9.680	57,25	DAX 07/15/16 P9200 Equity
01-07-2016	DAX	07-15-16	P	9.300	9.776	48,56	DAX 07/15/16 P9300 Equity
04-07-2016	DAX	07-15-16	P	9.200	9.709	36,45	DAX 07/15/16 P9200 Equity
05-07-2016	DAX	07-15-16	P	9.050	9.533	43,92	DAX 07/15/16 P9050 Equity
06-07-2016	DAX	07-15-16	P	8.900	9.373	42,47	DAX 07/15/16 P8900 Equity
07-07-2016	DAX	07-15-16	P	8.950	9.419	26	DAX 07/15/16 P8950 Equity
08-07-2016	DAX	07-15-16	P	9.150	9.630	12,93	DAX 07/15/16 P9150 Equity
11-07-2016	DAX	07-15-16	P	9.350	9.833	10,61	DAX 07/15/16 P9350 Equity
12-07-2016	DAX	07-15-16	P	9.450	9.964	5,99	DAX 07/15/16 P9450 Equity
13-07-2016	DAX	07-15-16	P	9.450	9.931	4,11	DAX 07/15/16 P9450 Equity
14-07-2016	DAX	07-15-16	P	9.550	10.068	0,78	DAX 07/15/16 P9550 Equity
15-07-2016	DAX	07-15-16	P	9.550	10.067	0,01	DAX 07/15/16 P9550 Equity

Testing high volatility expectation trades – 2016 events

Long strangle data for calls – FTSE index

Buy 1 OTM Call K2

Buy 1 ITM Put K1

LONG STRANGLE - FTSE index

5,00%

K2

Buy date	Asset	Maturity date	Call/Put	Strike Price	Spot Price	Option Price	Ticker
17-12-2015	UKX	06-17-16	C	6.400	6.103	563	UKX 06/17/16 C6400 Equity
17-03-2016	UKX	06-17-16	C	6.500	6.201	602,1	UKX 06/17/16 C6500 Equity
20-05-2016	UKX	06-17-16	C	6.450	6.156	8,7	UKX 06/17/16 C6450 Equity
23-05-2016	UKX	06-17-16	C	6.450	6.136	8,7	UKX 06/17/16 C6450 Equity
24-05-2016	UKX	06-17-16	C	6.500	6.219	10,2	UKX 06/17/16 C6500 Equity
25-05-2016	UKX	06-17-16	C	6.550	6.263	7,3	UKX 06/17/16 C6550 Equity
26-05-2016	UKX	06-17-16	C	6.550	6.266	5,1	UKX 06/17/16 C6550 Equity
27-05-2016	UKX	06-17-16	C	6.550	6.271	3,7	UKX 06/17/16 C6550 Equity
31-05-2016	UKX	06-17-16	C	6.550	6.231	2,2	UKX 06/17/16 C6550 Equity
01-06-2016	UKX	06-17-16	C	6.500	6.192	2,2	UKX 06/17/16 C6500 Equity
02-06-2016	UKX	06-17-16	C	6.500	6.186	1,4	UKX 06/17/16 C6500 Equity
03-06-2016	UKX	06-17-16	C	6.500	6.210	1,5	UKX 06/17/16 C6500 Equity
06-06-2016	UKX	06-17-16	C	6.550	6.273	1,4	UKX 06/17/16 C6550 Equity
07-06-2016	UKX	06-17-16	C	6.600	6.285	0,7	UKX 06/17/16 C6600 Equity
08-06-2016	UKX	06-17-16	C	6.600	6.302	0,7	UKX 06/17/16 C6600 Equity
09-06-2016	UKX	06-17-16	C	6.550	6.232	0,7	UKX 06/17/16 C6550 Equity
10-06-2016	UKX	06-17-16	C	6.400	6.116	1,4	UKX 06/17/16 C6400 Equity
13-06-2016	UKX	06-17-16	C	6.350	6.045	0,7	UKX 06/17/16 C6350 Equity
14-06-2016	UKX	06-17-16	C	6.200	5.924	1,4	UKX 06/17/16 C6200 Equity
15-06-2016	UKX	06-17-16	C	6.250	5.967	0	UKX 06/17/16 C6250 Equity
16-06-2016	UKX	06-17-16	C	6.250	5.950	0	UKX 06/17/16 C6250 Equity
17-06-2016	UKX	06-17-16	C	6.300	6.021	0	UKX 06/17/16 C6300 Equity
18-01-2016	UKX	07-15-16	C	6.100	5.780	204,7	UKX 07-15-16 C6100 Equity
18-04-2016	UKX	07-15-16	C	6.650	6.354	92,8	UKX 07-15-16 C6650 Equity
17-06-2016	UKX	07-15-16	C	6.300	6.021	87,3	UKX 07-15-16 C6300 Equity
20-06-2016	UKX	07-15-16	C	6.500	6.204	53,6	UKX 07-15-16 C6500 Equity
21-06-2016	UKX	07-15-16	C	6.550	6.227	47,7	UKX 07-15-16 C6550 Equity
22-06-2016	UKX	07-15-16	C	6.550	6.261	76,5	UKX 07-15-16 C6550 Equity
23-06-2016	UKX	07-15-16	C	6.650	6.338	18,5	UKX 07-15-16 C6650 Equity
24-06-2016	UKX	07-15-16	C	6.450	6.139	31	UKX 07-15-16 C6450 Equity
27-06-2016	UKX	07-15-16	C	6.300	5.982	33,7	UKX 07-15-16 C6300 Equity
28-06-2016	UKX	07-15-16	C	6.450	6.140	16,7	UKX 07-15-16 C6450 Equity
29-06-2016	UKX	07-15-16	C	6.650	6.360	12,8	UKX 07-15-16 C6650 Equity
30-06-2016	UKX	07-15-16	C	6.850	6.504	1,3	UKX 07-15-16 C6850 Equity
01-07-2016	UKX	07-15-16	C	6.950	6.578	1,3	UKX 07-15-16 C6950 Equity
04-07-2016	UKX	07-15-16	C	6.850	6.522	1,3	UKX 07-15-16 C6850 Equity
05-07-2016	UKX	07-15-16	C	6.900	6.545	0,7	UKX 07-15-16 C6900 Equity
06-07-2016	UKX	07-15-16	C	6.750	6.464	4,5	UKX 07-15-16 C6750 Equity
07-07-2016	UKX	07-15-16	C	6.900	6.534	0	UKX 07-15-16 C6900 Equity
08-07-2016	UKX	07-15-16	C	6.950	6.591	0	UKX 07-15-16 C6950 Equity
11-07-2016	UKX	07-15-16	C	7.050	6.683	0	UKX 07-15-16 C7050 Equity
12-07-2016	UKX	07-15-16	C	7.050	6.681	0,7	UKX 07-15-16 C7050 Equity
13-07-2016	UKX	07-15-16	C	7.000	6.670	0,7	UKX 07-15-16 C7000 Equity
14-07-2016	UKX	07-15-16	C	7.000	6.654	0	UKX 07-15-16 C7000 Equity
15-07-2016	UKX	07-15-16	C	7.000	6.669	0	UKX 07-15-16 C7000 Equity

Testing high volatility expectation trades – 2016 events

Long strangle data for puts – FTSE index

LONG STRANGLE - FTSE index

5,00%

K2

Buy date	Asset	Maturity date	Call/Put	Strike Price	Spot Price	Option Price	Ticker
17-12-2015	UKX	06-17-16	P	5.800	6.103	336,6	UKX 06/17/16 P5800 Equity
17-03-2016	UKX	06-17-16	P	5.900	6.201	186,7	UKX 06/17/16 P5900 Equity
20-05-2016	UKX	06-17-16	P	5.850	6.156	45	UKX 06/17/16 P5850 Equity
23-05-2016	UKX	06-17-16	P	5.850	6.136	37,7	UKX 06/17/16 P5850 Equity
24-05-2016	UKX	06-17-16	P	5.900	6.219	27,1	UKX 06/17/16 P5900 Equity
25-05-2016	UKX	06-17-16	P	5.950	6.263	25	UKX 06/17/16 P5950 Equity
26-05-2016	UKX	06-17-16	P	5.950	6.266	22,7	UKX 06/17/16 P5950 Equity
27-05-2016	UKX	06-17-16	P	5.950	6.271	17,6	UKX 06/17/16 P5950 Equity
31-05-2016	UKX	06-17-16	P	5.950	6.231	21,8	UKX 06/17/16 P5950 Equity
01-06-2016	UKX	06-17-16	P	5.900	6.192	22,4	UKX 06/17/16 P5900 Equity
02-06-2016	UKX	06-17-16	P	5.900	6.186	18	UKX 06/17/16 P5900 Equity
03-06-2016	UKX	06-17-16	P	5.900	6.210	16,7	UKX 06/17/16 P5900 Equity
06-06-2016	UKX	06-17-16	P	5.950	6.273	8,7	UKX 06/17/16 P5950 Equity
07-06-2016	UKX	06-17-16	P	6.000	6.285	10,9	UKX 06/17/16 P6000 Equity
08-06-2016	UKX	06-17-16	P	6.000	6.302	6,5	UKX 06/17/16 P6000 Equity
09-06-2016	UKX	06-17-16	P	5.950	6.232	9,4	UKX 06/17/16 P5950 Equity
10-06-2016	UKX	06-17-16	P	5.800	6.116	12,2	UKX 06/17/16 P5800 Equity
13-06-2016	UKX	06-17-16	P	5.750	6.045	8,5	UKX 06/17/16 P5750 Equity
14-06-2016	UKX	06-17-16	P	5.600	5.924	5,7	UKX 06/17/16 P5600 Equity
15-06-2016	UKX	06-17-16	P	5.650	5.967	1,4	UKX 06/17/16 P5650 Equity
16-06-2016	UKX	06-17-16	P	5.650	5.950	0	UKX 06/17/16 P5650 Equity
17-06-2016	UKX	06-17-16	P	5.700	6.021	0	UKX 06/17/16 P5700 Equity
18-01-2016	UKX	07-15-16	P	5.500	5.780	399,3	UKX 07/15/16 P5500 Equity
18-04-2016	UKX	07-15-16	P	6.050	6.354	208,4	UKX 07/15/16 P6050 Equity
17-06-2016	UKX	07-15-16	P	5.700	6.021	143,1	UKX 07/15/16 P5700 Equity
20-06-2016	UKX	07-15-16	P	5.900	6.204	118,2	UKX 07/15/16 P5900 Equity
21-06-2016	UKX	07-15-16	P	5.950	6.227	132	UKX 07/15/16 P5950 Equity
22-06-2016	UKX	07-15-16	P	5.950	6.261	131,6	UKX 07/15/16 P5950 Equity
23-06-2016	UKX	07-15-16	P	6.050	6.338	137	UKX 07/15/16 P6050 Equity
24-06-2016	UKX	07-15-16	P	5.850	6.139	86,7	UKX 07/15/16 P5850 Equity
27-06-2016	UKX	07-15-16	P	5.700	5.982	91,8	UKX 07/15/16 P5700 Equity
28-06-2016	UKX	07-15-16	P	5.850	6.140	64	UKX 07/15/16 P5850 Equity
29-06-2016	UKX	07-15-16	P	6.050	6.360	54,6	UKX 07/15/16 P6050 Equity
30-06-2016	UKX	07-15-16	P	6.150	6.504	34,5	UKX 07/15/16 P6150 Equity
01-07-2016	UKX	07-15-16	P	6.250	6.578	26,6	UKX 07/15/16 P6250 Equity
04-07-2016	UKX	07-15-16	P	6.150	6.522	19,3	UKX 07/15/16 P6150 Equity
05-07-2016	UKX	07-15-16	P	6.200	6.545	17,6	UKX 07/15/16 P6200 Equity
06-07-2016	UKX	07-15-16	P	6.150	6.464	22,7	UKX 07/15/16 P6150 Equity
07-07-2016	UKX	07-15-16	P	6.200	6.534	11	UKX 07/15/16 P6200 Equity
08-07-2016	UKX	07-15-16	P	6.250	6.591	3,9	UKX 07/15/16 P6250 Equity
11-07-2016	UKX	07-15-16	P	6.350	6.683	2,6	UKX 07/15/16 P6350 Equity
12-07-2016	UKX	07-15-16	P	6.350	6.681	2	UKX 07/15/16 P6350 Equity
13-07-2016	UKX	07-15-16	P	6.300	6.670	1,3	UKX 07/15/16 P6300 Equity
14-07-2016	UKX	07-15-16	P	6.300	6.654	0,7	UKX 07/15/16 P6300 Equity
15-07-2016	UKX	07-15-16	P	6.300	6.669	0	UKX 07/15/16 P6300 Equity

Testing high volatility expectation trades – 2016 events

Strike prices for long strangle – FTSE 100

FTSE 100				
	-5%	5%	K1	K2
6100	-310	310	5790	6410
6200	-310	310	5890	6510
6150	-310	310	5840	6460
6150	-310	310	5840	6460
6200	-310	310	5890	6510
6250	-310	310	5940	6560
6250	-310	310	5940	6560
6250	-310	310	5940	6560
6250	-310	310	5940	6560
6200	-310	310	5890	6510
6200	-310	310	5890	6510
6200	-310	310	5890	6510
6250	-310	310	5940	6560
6300	-320	320	5980	6620
6300	-320	320	5980	6620
6250	-310	310	5940	6560
6100	-310	310	5790	6410
6050	-300	300	5750	6350
5900	-300	300	5600	6200
5950	-300	300	5650	6250
5950	-300	300	5650	6250
6000	-300	300	5700	6300
5800	-290	290	5510	6090
6350	-320	320	6030	6670
6000	-300	300	5700	6300
6200	-310	310	5890	6510
6250	-310	310	5940	6560
6250	-310	310	5940	6560
6350	-320	320	6030	6670
6150	-310	310	5840	6460
6000	-300	300	5700	6300
6150	-310	310	5840	6460
6350	-320	320	6030	6670
6500	-330	330	6170	6830
6600	-330	330	6270	6930
6500	-330	330	6170	6830
6550	-330	330	6220	6880

Testing high volatility expectation trades – 2016 events

FTSE 100				
	-5%	5%	K1	K2
6450	-320	320	6130	6770
6550	-330	330	6220	6880
6600	-330	330	6270	6930
6700	-340	340	6360	7040
6700	-340	340	6360	7040
6650	-330	330	6320	6980
6650	-330	330	6320	6980
6650	-330	330	6320	6980

Strike prices for long strangle – DAX 30

DAX				
	-5%	5%	K1	K2
10750	-540	540	10210	11290
9900	-500	500	9400	10400
9900	-500	500	9400	10400
9850	-490	490	9360	10340
10050	-500	500	9550	10550
10200	-510	510	9690	10710
10250	-510	510	9740	10760
10300	-520	520	9780	10820
10350	-520	520	9830	10870
10250	-510	510	9740	10760
10200	-510	510	9690	10710
10200	-510	510	9690	10710
10100	-510	510	9590	10610
10100	-510	510	9590	10610
10300	-520	520	9780	10820
10200	-510	510	9690	10710
10100	-510	510	9590	10610
9850	-490	490	9360	10340
9650	-480	480	9170	10130
9500	-480	480	9020	9980
9600	-480	480	9120	10080
9550	-480	480	9070	10030
9650	-480	480	9170	10130
9500	-480	480	9020	9980
10100	-510	510	9590	10610

Testing high volatility expectation trades – 2016 events

DAX				
	-5%	5%	K1	K2
9650	-480	480	9170	10130
9950	-500	500	9450	10450
10000	-500	500	9500	10500
10050	-500	500	9550	10550
10250	-510	510	9740	10760
9550	-480	480	9070	10030
9250	-460	460	8790	9710
9450	-470	470	8980	9920
9600	-480	480	9120	10080
9700	-490	490	9210	10190
9800	-490	490	9310	10290
9700	-490	490	9210	10190
9550	-480	480	9070	10030
9350	-470	470	8880	9820
9400	-470	470	8930	9870
9650	-480	480	9170	10130
9850	-490	490	9360	10340
9950	-500	500	9450	10450
9950	-500	500	9450	10450
10050	-500	500	9550	10550
10050	-500	500	9550	10550

Testing high volatility expectation trades – 2016 events

Short butterfly spread data for K1 (strike 1) – DAX index

Sell 1 ITM Call K1
 Sell 1 OTM Call K2
 Buy 2 ATM Call K'

SHORT BUTTERFLY SPREAD WITH CALLS - DAX index

-6,00%

K1

Buy date	Asset	Maturity date	Call/Put	Strike	Pric	Spot Price	Option Price	Ticker
17-12-2015	DAX	06-17-16	C	10.100		10.738	1185,44	DAX 06-17-16 C10100 Equity
17-03-2016	DAX	06-17-16	C	9.300		9.892	948	DAX 06-17-16 C9300 Equity
20-05-2016	DAX	06-17-16	C	9.300		9.916	749,7	DAX 06-17-16 C9300 Equity
23-05-2016	DAX	06-17-16	C	9.250		9.842	739,97	DAX 06-17-16 C9250 Equity
24-05-2016	DAX	06-17-16	C	9.450		10.057	737,28	DAX 06-17-16 C9450 Equity
25-05-2016	DAX	06-17-16	C	9.600		10.205	718,75	DAX 06-17-16 C9600 Equity
26-05-2016	DAX	06-17-16	C	9.650		10.273	735,72	DAX 06-17-16 C9650 Equity
27-05-2016	DAX	06-17-16	C	9.700		10.286	669,78	DAX 06-17-16 C9700 Equity
30-05-2016	DAX	06-17-16	C	9.750		10.333	679,17	DAX 06-17-16 C9750 Equity
31-05-2016	DAX	06-17-16	C	9.650		10.263	709,55	DAX 06-17-16 C9650 Equity
01-06-2016	DAX	06-17-16	C	9.600		10.204	696,25	DAX 06-17-16 C9600 Equity
02-06-2016	DAX	06-17-16	C	9.600		10.208	714,43	DAX 06-17-16 C9600 Equity
03-06-2016	DAX	06-17-16	C	9.500		10.103	690,43	DAX 06-17-16 C9500 Equity
06-06-2016	DAX	06-17-16	C	9.500		10.121	731,83	DAX 06-17-16 C9500 Equity
07-06-2016	DAX	06-17-16	C	9.700		10.288	676,63	DAX 06-17-16 C9700 Equity
08-06-2016	DAX	06-17-16	C	9.600		10.217	696,25	DAX 06-17-16 C9600 Equity
09-06-2016	DAX	06-17-16	C	9.500		10.089	670,76	DAX 06-17-16 C9500 Equity
10-06-2016	DAX	06-17-16	C	9.250		9.835	671,83	DAX 06-17-16 C9250 Equity
13-06-2016	DAX	06-17-16	C	9.050		9.657	722,29	DAX 06-17-16 C9050 Equity
14-06-2016	DAX	06-17-16	C	8.950		9.519	639,93	DAX 06-17-16 C8950 Equity
15-06-2016	DAX	06-17-16	C	9.050		9.607	704,62	DAX 06-17-16 C9050 Equity
16-06-2016	DAX	06-17-16	C	9.000		9.550	637,9	DAX 06-17-16 C9000 Equity
17-06-2016	DAX	06-17-16	C	9.050		9.631	655,65	DAX 06-17-16 C9050 Equity
18-01-2016	DAX	07-15-16	C	8.950		9.522	-	DAX 07-15-16 C8950 Equity
18-04-2016	DAX	07-15-16	C	9.500		10.120	995,13	DAX 07-15-16 C9500 Equity
17-06-2016	DAX	07-15-16	C	9.050		9.631	831,73	DAX 07-15-16 C9050 Equity
20-06-2016	DAX	07-15-16	C	9.350		9.962	846,25	DAX 07-15-16 C9350 Equity
21-06-2016	DAX	07-15-16	C	9.400		10.016	878,88	DAX 07-15-16 C9400 Equity
22-06-2016	DAX	07-15-16	C	9.450		10.071	948,77	DAX 07-15-16 C9450 Equity
23-06-2016	DAX	07-15-16	C	9.650		10.257	826,04	DAX 07-15-16 C9650 Equity
24-06-2016	DAX	07-15-16	C	9.000		9.557	762,08	DAX 07-15-16 C9000 Equity
27-06-2016	DAX	07-15-16	C	8.700		9.269	721,11	DAX 07-15-16 C8700 Equity
28-06-2016	DAX	07-15-16	C	8.900		9.447	661,52	DAX 07-15-16 C8900 Equity
29-06-2016	DAX	07-15-16	C	9.050		9.612	628,26	DAX 07-15-16 C9050 Equity
30-06-2016	DAX	07-15-16	C	9.100		9.680	684,2	DAX 07-15-16 C9100 Equity
01-07-2016	DAX	07-15-16	C	9.200		9.776	667,44	DAX 07-15-16 C9200 Equity
04-07-2016	DAX	07-15-16	C	9.100		9.709	711,02	DAX 07-15-16 C9100 Equity
05-07-2016	DAX	07-15-16	C	9.000		9.533	622,15	DAX 07-15-16 C9000 Equity
06-07-2016	DAX	07-15-16	C	8.800		9.373	657,69	DAX 07-15-16 C8800 Equity
07-07-2016	DAX	07-15-16	C	8.850		9.419	648,35	DAX 07-15-16 C8850 Equity
08-07-2016	DAX	07-15-16	C	9.050		9.630	656	DAX 07-15-16 C9050 Equity
11-07-2016	DAX	07-15-16	C	9.250		9.833	649,47	DAX 07-15-16 C9250 Equity
12-07-2016	DAX	07-15-16	C	9.350		9.964	695,02	DAX 07-15-16 C9350 Equity
13-07-2016	DAX	07-15-16	C	9.350		9.931	669,76	DAX 07-15-16 C9350 Equity
14-07-2016	DAX	07-15-16	C	9.450		10.068	689,34	DAX 07-15-16 C9450 Equity
15-07-2016	DAX	07-15-16	C	9.450		10.067	594,39	DAX 07-15-16 C9450 Equity

Testing high volatility expectation trades – 2016 events

Short butterfly spread data for K2 (strike 2) – DAX index

SHORT BUTTERFLY SPREAD WITH CALLS - DAX index

6,00%

K2

Buy date	Asset	Maturity date	Call/Put	Strike Pric	Spot Price	Option Price	Ticker
17-12-2015	DAX	06-17-16	C	11.400	10.738	410,26	DAX 06-17-16 C11400 Equity
17-03-2016	DAX	06-17-16	C	10.500	9.892	186,18	DAX 06-17-16 C10500 Equity
20-05-2016	DAX	06-17-16	C	10.500	9.916	28,37	DAX 06-17-16 C10500 Equity
23-05-2016	DAX	06-17-16	C	10.450	9.842	24,55	DAX 06-17-16 C10450 Equity
24-05-2016	DAX	06-17-16	C	10.650	10.057	18,4	DAX 06-17-16 C10650 Equity
25-05-2016	DAX	06-17-16	C	10.800	10.205	13,84	DAX 06-17-16 C10800 Equity
26-05-2016	DAX	06-17-16	C	10.850	10.273	15,2	DAX 06-17-16 C10850 Equity
27-05-2016	DAX	06-17-16	C	10.900	10.286	9,13	DAX 06-17-16 C10900 Equity
30-05-2016	DAX	06-17-16	C	10.950	10.333	8,35	DAX 06-17-16 C10950 Equity
31-05-2016	DAX	06-17-16	C	10.850	10.263	8,91	DAX 06-17-16 C10850 Equity
01-06-2016	DAX	06-17-16	C	10.800	10.204	7,15	DAX 06-17-16 C10800 Equity
02-06-2016	DAX	06-17-16	C	10.800	10.208	5,47	DAX 06-17-16 C10800 Equity
03-06-2016	DAX	06-17-16	C	10.700	10.103	4,19	DAX 06-17-16 C10700 Equity
06-06-2016	DAX	06-17-16	C	10.700	10.121	3,07	DAX 06-17-16 C10700 Equity
07-06-2016	DAX	06-17-16	C	10.900	10.288	2,04	DAX 06-17-16 C10900 Equity
08-06-2016	DAX	06-17-16	C	10.800	10.217	2,05	DAX 06-17-16 C10800 Equity
09-06-2016	DAX	06-17-16	C	10.700	10.089	1,7	DAX 06-17-16 C10700 Equity
10-06-2016	DAX	06-17-16	C	10.450	9.835	1,69	DAX 06-17-16 C10450 Equity
13-06-2016	DAX	06-17-16	C	10.250	9.657	2,14	DAX 06-17-16 C10250 Equity
14-06-2016	DAX	06-17-16	C	10.050	9.519	3,25	DAX 06-17-16 C10050 Equity
15-06-2016	DAX	06-17-16	C	10.200	9.607	0,45	DAX 06-17-16 C10200 Equity
16-06-2016	DAX	06-17-16	C	10.150	9.550	0,11	DAX 06-17-16 C10150 Equity
17-06-2016	DAX	06-17-16	C	10.250	9.631	0,01	DAX 06-17-16 C10250 Equity
18-01-2016	DAX	07-15-16	C	10.050	9.522	-	DAX 07-15-16 C10050 Equity
18-04-2016	DAX	07-15-16	C	10.700	10.120	200,11	DAX 07-15-16 C10700 Equity
17-06-2016	DAX	07-15-16	C	10.250	9.631	100,84	DAX 07-15-16 C10250 Equity
20-06-2016	DAX	07-15-16	C	10.550	9.962	72,19	DAX 07-15-16 C10550 Equity
21-06-2016	DAX	07-15-16	C	10.600	10.016	70,48	DAX 07-15-16 C10600 Equity
22-06-2016	DAX	07-15-16	C	10.650	10.071	98,45	DAX 07-15-16 C10650 Equity
23-06-2016	DAX	07-15-16	C	10.850	10.257	41,55	DAX 07-15-16 C10850 Equity
24-06-2016	DAX	07-15-16	C	10.150	9.557	75,93	DAX 07-15-16 C10150 Equity
27-06-2016	DAX	07-15-16	C	9.800	9.269	70,64	DAX 07-15-16 C9800 Equity
28-06-2016	DAX	07-15-16	C	10.000	9.447	35,7	DAX 07-15-16 C10000 Equity
29-06-2016	DAX	07-15-16	C	10.200	9.612	24,3	DAX 07-15-16 C10200 Equity
30-06-2016	DAX	07-15-16	C	10.300	9.680	10,08	DAX 07-15-16 C10300 Equity
01-07-2016	DAX	07-15-16	C	10.400	9.776	6,57	DAX 07-15-16 C10400 Equity
04-07-2016	DAX	07-15-16	C	10.300	9.709	5,02	DAX 07-15-16 C10300 Equity
05-07-2016	DAX	07-15-16	C	10.150	9.533	5,43	DAX 07-15-16 C10150 Equity
06-07-2016	DAX	07-15-16	C	9.900	9.373	9,31	DAX 07-15-16 C9900 Equity
07-07-2016	DAX	07-15-16	C	9.950	9.419	5,2	DAX 07-15-16 C9950 Equity
08-07-2016	DAX	07-15-16	C	10.250	9.630	0,55	DAX 07-15-16 C10250 Equity
11-07-2016	DAX	07-15-16	C	10.450	9.833	0,77	DAX 07-15-16 C10450 Equity
12-07-2016	DAX	07-15-16	C	10.550	9.964	1,44	DAX 07-15-16 C10550 Equity
13-07-2016	DAX	07-15-16	C	10.550	9.931	1,56	DAX 07-15-16 C10550 Equity
14-07-2016	DAX	07-15-16	C	10.650	10.068	0,67	DAX 07-15-16 C10650 Equity
15-07-2016	DAX	07-15-16	C	10.650	10.067	0,01	DAX 07-15-16 C10650 Equity

Testing high volatility expectation trades – 2016 events

Short butterfly spread data for K' (middle strike) – DAX index

SHORT BUTTERFLY SPREAD WITH CALLS - DAX index

ATM

K'

Buy date	Asset	Maturity date	Call/Put	Strike	Pric	Spot Price	Option Price	Ticker
17-12-2015	DAX	06-17-16	C	10.750		10.738	741,1	DAX 06-17-16 C10750 Equity
17-03-2016	DAX	06-17-16	C	9.900		9.892	490,97	DAX 06-17-16 C9900 Equity
20-05-2016	DAX	06-17-16	C	9.900		9.916	253,53	DAX 06-17-16 C9900 Equity
23-05-2016	DAX	06-17-16	C	9.850		9.842	240,9	DAX 06-17-16 C9850 Equity
24-05-2016	DAX	06-17-16	C	10.050		10.057	225,43	DAX 06-17-16 C10050 Equity
25-05-2016	DAX	06-17-16	C	10.200		10.205	203,21	DAX 06-17-16 C10200 Equity
26-05-2016	DAX	06-17-16	C	10.250		10.273	207,65	DAX 06-17-16 C10250 Equity
27-05-2016	DAX	06-17-16	C	10.300		10.286	159,26	DAX 06-17-16 C10300 Equity
30-05-2016	DAX	06-17-16	C	10.350		10.333	158,88	DAX 06-17-16 C10350 Equity
31-05-2016	DAX	06-17-16	C	10.250		10.263	176,33	DAX 06-17-16 C10250 Equity
01-06-2016	DAX	06-17-16	C	10.200		10.204	168,62	DAX 06-17-16 C10200 Equity
02-06-2016	DAX	06-17-16	C	10.200		10.208	167,34	DAX 06-17-16 C10200 Equity
03-06-2016	DAX	06-17-16	C	10.100		10.103	145,43	DAX 06-17-16 C10100 Equity
06-06-2016	DAX	06-17-16	C	10.100		10.121	154,97	DAX 06-17-16 C10100 Equity
07-06-2016	DAX	06-17-16	C	10.300		10.288	112,13	DAX 06-17-16 C10300 Equity
08-06-2016	DAX	06-17-16	C	10.200		10.217	114,79	DAX 06-17-16 C10200 Equity
09-06-2016	DAX	06-17-16	C	10.100		10.089	99,72	DAX 06-17-16 C10100 Equity
10-06-2016	DAX	06-17-16	C	9.850		9.835	124,51	DAX 06-17-16 C9850 Equity
13-06-2016	DAX	06-17-16	C	9.650		9.657	150,98	DAX 06-17-16 C9650 Equity
14-06-2016	DAX	06-17-16	C	9.500		9.519	138,14	DAX 06-17-16 C9500 Equity
15-06-2016	DAX	06-17-16	C	9.625		9.607	108	DAX 06-17-16 C9625 Equity
16-06-2016	DAX	06-17-16	C	9.575		9.550	62,42	DAX 06-17-16 C9575 Equity
17-06-2016	DAX	06-17-16	C	9.650		9.631	0,01	DAX 06-17-16 C9650 Equity
18-01-2016	DAX	07-15-16	C	9.500		9.522	-	DAX 07-15-16 C9500 Equity
18-04-2016	DAX	07-15-16	C	10.100		10.120	524,91	DAX 07-15-16 C10100 Equity
17-06-2016	DAX	07-15-16	C	9.650		9.631	385,33	DAX 07-15-16 C9650 Equity
20-06-2016	DAX	07-15-16	C	9.950		9.962	368,42	DAX 07-15-16 C9950 Equity
21-06-2016	DAX	07-15-16	C	10.000		10.016	385,4	DAX 07-15-16 C10000 Equity
22-06-2016	DAX	07-15-16	C	10.050		10.071	448,16	DAX 07-15-16 C10050 Equity
23-06-2016	DAX	07-15-16	C	10.250		10.257	330,26	DAX 07-15-16 C10250 Equity
24-06-2016	DAX	07-15-16	C	9.575		9.557	333,31	DAX 07-15-16 C9575 Equity
27-06-2016	DAX	07-15-16	C	9.250		9.269	303,54	DAX 07-15-16 C9250 Equity
28-06-2016	DAX	07-15-16	C	9.450		9.447	241,18	DAX 07-15-16 C9450 Equity
29-06-2016	DAX	07-15-16	C	9.625		9.612	206,53	DAX 07-15-16 C9625 Equity
30-06-2016	DAX	07-15-16	C	9.700		9.680	190,12	DAX 07-15-16 C9700 Equity
01-07-2016	DAX	07-15-16	C	9.800		9.776	163,71	DAX 07-15-16 C9800 Equity
04-07-2016	DAX	07-15-16	C	9.700		9.709	180,04	DAX 07-15-16 C9700 Equity
05-07-2016	DAX	07-15-16	C	9.575		9.533	162,58	DAX 07-15-16 C9575 Equity
06-07-2016	DAX	07-15-16	C	9.350		9.373	189,07	DAX 07-15-16 C9350 Equity
07-07-2016	DAX	07-15-16	C	9.400		9.419	164,85	DAX 07-15-16 C9400 Equity
08-07-2016	DAX	07-15-16	C	9.650		9.630	114,64	DAX 07-15-16 C9650 Equity
11-07-2016	DAX	07-15-16	C	9.850		9.833	92,85	DAX 07-15-16 C9850 Equity
12-07-2016	DAX	07-15-16	C	9.950		9.964	97,39	DAX 07-15-16 C9950 Equity
13-07-2016	DAX	07-15-16	C	9.950		9.931	69,99	DAX 07-15-16 C9950 Equity
14-07-2016	DAX	07-15-16	C	10.050		10.068	54,68	DAX 07-15-16 C10050 Equity
15-07-2016	DAX	07-15-16	C	10.050		10.067	0,01	DAX 07-15-16 C10050 Equity

Testing high volatility expectation trades – 2016 events

Short butterfly spread data for K1 (strike 1) – FTSE index

Sell 1 ITM Call K1

Sell 1 OTM Call K2

Buy 2 ATM Call K'

SHORT BUTTERFLY SPREAD WITH CALLS - FTSE index

-6,00%

K1

Buy date	Asset	Maturity date	Call/Put	Strike Pric	Spot Price	Option Price	Ticker
17-12-2015	UKX	06-17-16	C	5.750	6.103	707,4	UKX 06/17/16 C5750 Equity
17-03-2016	UKX	06-17-16	C	5.850	6.201	567,4	UKX 06/17/16 C5850 Equity
20-05-2016	UKX	06-17-16	C	5.800	6.156	522,5	UKX 06/17/16 C5800 Equity
23-05-2016	UKX	06-17-16	C	5.800	6.136	511,3	UKX 06/17/16 C5800 Equity
24-05-2016	UKX	06-17-16	C	5.850	6.219	556,5	UKX 06/17/16 C5850 Equity
25-05-2016	UKX	06-17-16	C	5.850	6.263	605,1	UKX 06/17/16 C5850 Equity
26-05-2016	UKX	06-17-16	C	5.850	6.266	604,5	UKX 06/17/16 C5850 Equity
27-05-2016	UKX	06-17-16	C	5.850	6.271	597,2	UKX 06/17/16 C5850 Equity
31-05-2016	UKX	06-17-16	C	5.850	6.231	547,9	UKX 06/17/16 C5850 Equity
01-06-2016	UKX	06-17-16	C	5.850	6.192	476,6	UKX 06/17/16 C5850 Equity
02-06-2016	UKX	06-17-16	C	5.850	6.186	496,6	UKX 06/17/16 C5850 Equity
03-06-2016	UKX	06-17-16	C	5.850	6.210	513,2	UKX 06/17/16 C5850 Equity
06-06-2016	UKX	06-17-16	C	5.850	6.273	620,4	UKX 06/17/16 C5850 Equity
07-06-2016	UKX	06-17-16	C	5.900	6.285	541,2	UKX 06/17/16 C5900 Equity
08-06-2016	UKX	06-17-16	C	5.900	6.302	574,1	UKX 06/17/16 C5900 Equity
09-06-2016	UKX	06-17-16	C	5.850	6.232	552,5	UKX 06/17/16 C5850 Equity
10-06-2016	UKX	06-17-16	C	5.750	6.116	539,1	UKX 06/17/16 C5750 Equity
13-06-2016	UKX	06-17-16	C	5.700	6.045	517,3	UKX 06/17/16 C5700 Equity
14-06-2016	UKX	06-17-16	C	5.550	5.924	529,8	UKX 06/17/16 C5550 Equity
15-06-2016	UKX	06-17-16	C	5.600	5.967	539,1	UKX 06/17/16 C5600 Equity
16-06-2016	UKX	06-17-16	C	5.600	5.950	515,3	UKX 06/17/16 C5600 Equity
17-06-2016	UKX	06-17-16	C	5.650	6.021	564,7	UKX 06/17/16 C5650 Equity
18-01-2016	UKX	07-15-16	C	5.450	5.780	-	UKX 07/15/16 C5450 Equity
18-04-2016	UKX	07-15-16	C	5.950	6.354	683,9	UKX 07/15/16 C5950 Equity
17-06-2016	UKX	07-15-16	C	5.650	6.021	636,3	UKX 07/15/16 C5650 Equity
20-06-2016	UKX	07-15-16	C	5.850	6.204	631,2	UKX 07/15/16 C5850 Equity
21-06-2016	UKX	07-15-16	C	5.850	6.227	690,6	UKX 07/15/16 C5850 Equity
22-06-2016	UKX	07-15-16	C	5.850	6.261	770,5	UKX 07/15/16 C5850 Equity
23-06-2016	UKX	07-15-16	C	5.950	6.338	662,7	UKX 07/15/16 C5950 Equity
24-06-2016	UKX	07-15-16	C	5.800	6.139	569,6	UKX 07/15/16 C5800 Equity
27-06-2016	UKX	07-15-16	C	5.650	5.982	511,4	UKX 07/15/16 C5650 Equity
28-06-2016	UKX	07-15-16	C	5.800	6.140	484,5	UKX 07/15/16 C5800 Equity
29-06-2016	UKX	07-15-16	C	5.950	6.360	559,1	UKX 07/15/16 C5950 Equity
30-06-2016	UKX	07-15-16	C	6.100	6.504	529,4	UKX 07/15/16 C6100 Equity
01-07-2016	UKX	07-15-16	C	6.200	6.578	526,6	UKX 07/15/16 C6200 Equity
04-07-2016	UKX	07-15-16	C	6.100	6.522	582,3	UKX 07/15/16 C6100 Equity
05-07-2016	UKX	07-15-16	C	6.150	6.545	546,9	UKX 07/15/16 C6150 Equity
06-07-2016	UKX	07-15-16	C	6.050	6.464	557,9	UKX 07/15/16 C6050 Equity
07-07-2016	UKX	07-15-16	C	6.150	6.534	523,9	UKX 07/15/16 C6150 Equity
08-07-2016	UKX	07-15-16	C	6.200	6.591	524,4	UKX 07/15/16 C6200 Equity
11-07-2016	UKX	07-15-16	C	6.300	6.683	501,2	UKX 07/15/16 C6300 Equity
12-07-2016	UKX	07-15-16	C	6.300	6.681	507,3	UKX 07/15/16 C6300 Equity
13-07-2016	UKX	07-15-16	C	6.250	6.670	592,3	UKX 07/15/16 C6250 Equity
14-07-2016	UKX	07-15-16	C	6.250	6.654	550,8	UKX 07/15/16 C6250 Equity
15-07-2016	UKX	07-15-16	C	6.250	6.669	508,1	UKX 07/15/16 C6250 Equity

Testing high volatility expectation trades – 2016 events

Short butterfly spread data for K2 (strike 2) – FTSE index

SHORT BUTTERFLY SPREAD WITH CALLS - FTSE index

6,00%

K2

Buy date	Asset	Maturity date	Call/Put	Strike	Pric	Spot Price	Option Price	Ticker
17-12-2015	UKX	06-17-16	C	6.450	6.103	6.103	159,4	UKX 06/17/16 C6450 Equity
17-03-2016	UKX	06-17-16	C	6.550	6.201	6.201	44,9	UKX 06/17/16 C6550 Equity
20-05-2016	UKX	06-17-16	C	6.500	6.156	6.156	4,4	UKX 06/17/16 C6500 Equity
23-05-2016	UKX	06-17-16	C	6.500	6.136	6.136	5,1	UKX 06/17/16 C6500 Equity
24-05-2016	UKX	06-17-16	C	6.550	6.219	6.219	6,6	UKX 06/17/16 C6550 Equity
25-05-2016	UKX	06-17-16	C	6.650	6.263	6.263	2,9	UKX 06/17/16 C6650 Equity
26-05-2016	UKX	06-17-16	C	6.650	6.266	6.266	1,5	UKX 06/17/16 C6650 Equity
27-05-2016	UKX	06-17-16	C	6.650	6.271	6.271	0,7	UKX 06/17/16 C6650 Equity
31-05-2016	UKX	06-17-16	C	6.650	6.231	6.231	0,7	UKX 06/17/16 C6650 Equity
01-06-2016	UKX	06-17-16	C	6.550	6.192	6.192	1,4	UKX 06/17/16 C6550 Equity
02-06-2016	UKX	06-17-16	C	6.550	6.186	6.186	0,7	UKX 06/17/16 C6550 Equity
03-06-2016	UKX	06-17-16	C	6.550	6.210	6.210	0,7	UKX 06/17/16 C6550 Equity
06-06-2016	UKX	06-17-16	C	6.650	6.273	6.273	0	UKX 06/17/16 C6650 Equity
07-06-2016	UKX	06-17-16	C	6.700	6.285	6.285	0	UKX 06/17/16 C6700 Equity
08-06-2016	UKX	06-17-16	C	6.700	6.302	6.302	0	UKX 06/17/16 C6700 Equity
09-06-2016	UKX	06-17-16	C	6.650	6.232	6.232	0	UKX 06/17/16 C6650 Equity
10-06-2016	UKX	06-17-16	C	6.450	6.116	6.116	0,7	UKX 06/17/16 C6450 Equity
13-06-2016	UKX	06-17-16	C	6.400	6.045	6.045	0	UKX 06/17/16 C6400 Equity
14-06-2016	UKX	06-17-16	C	6.250	5.924	5.924	0,7	UKX 06/17/16 C6250 Equity
15-06-2016	UKX	06-17-16	C	6.300	5.967	5.967	0	UKX 06/17/16 C6300 Equity
16-06-2016	UKX	06-17-16	C	6.300	5.950	5.950	0	UKX 06/17/16 C6300 Equity
17-06-2016	UKX	06-17-16	C	6.350	6.021	6.021	0	UKX 06/17/16 C6350 Equity
18-01-2016	UKX	07-15-16	C	6.150	5.780	5.780	180,4	UKX 07/15/16 C6150 Equity
18-04-2016	UKX	07-15-16	C	6.750	6.354	6.354	-	UKX 07/15/16 C6750 Equity
17-06-2016	UKX	07-15-16	C	6.350	6.021	6.021	67,3	UKX 07/15/16 C6350 Equity
20-06-2016	UKX	07-15-16	C	6.550	6.204	6.204	35,2	UKX 07/15/16 C6550 Equity
21-06-2016	UKX	07-15-16	C	6.650	6.227	6.227	19,1	UKX 07/15/16 C6650 Equity
22-06-2016	UKX	07-15-16	C	6.650	6.261	6.261	33,1	UKX 07/15/16 C6650 Equity
23-06-2016	UKX	07-15-16	C	6.750	6.338	6.338	4,4	UKX 07/15/16 C6750 Equity
24-06-2016	UKX	07-15-16	C	6.500	6.139	6.139	19,3	UKX 07/15/16 C6500 Equity
27-06-2016	UKX	07-15-16	C	6.350	5.982	5.982	21,8	UKX 07/15/16 C6350 Equity
28-06-2016	UKX	07-15-16	C	6.500	6.140	6.140	9,3	UKX 07/15/16 C6500 Equity
29-06-2016	UKX	07-15-16	C	6.750	6.360	6.360	3,4	UKX 07/15/16 C6750 Equity
30-06-2016	UKX	07-15-16	C	6.900	6.504	6.504	0,7	UKX 07/15/16 C6900 Equity
01-07-2016	UKX	07-15-16	C	7.000	6.578	6.578	0,7	UKX 07/15/16 C7000 Equity
04-07-2016	UKX	07-15-16	C	6.900	6.522	6.522	0,7	UKX 07/15/16 C6900 Equity
05-07-2016	UKX	07-15-16	C	6.950	6.545	6.545	0	UKX 07/15/16 C6950 Equity
06-07-2016	UKX	07-15-16	C	6.850	6.464	6.464	0,6	UKX 07/15/16 C6850 Equity
07-07-2016	UKX	07-15-16	C	6.950	6.534	6.534	0	UKX 07/15/16 C6950 Equity
08-07-2016	UKX	07-15-16	C	7.000	6.591	6.591	0	UKX 07/15/16 C7000 Equity
11-07-2016	UKX	07-15-16	C	7.100	6.683	6.683	0	UKX 07/15/16 C7100 Equity
12-07-2016	UKX	07-15-16	C	7.100	6.681	6.681	0,7	UKX 07/15/16 C7100 Equity
13-07-2016	UKX	07-15-16	C	7.050	6.670	6.670	0,7	UKX 07/15/16 C7050 Equity
14-07-2016	UKX	07-15-16	C	7.050	6.654	6.654	0	UKX 07/15/16 C7050 Equity
15-07-2016	UKX	07-15-16	C	7.050	6.669	6.669	0	UKX 07/15/16 C7050 Equity

Testing high volatility expectation trades – 2016 events

Short butterfly spread data for K' (middle strike) – FTSE index

SHORT BUTTERFLY SPREAD WITH CALLS - FTSE index

ATM

K'

Buy date	Asset	Maturity date	Call/Put	Strike	Pric	Spot Price	Option Price	Ticker
17-12-2015	UKX	06-17-16	C	6.100		6.103	382	UKX 06/17/16 C6100 Equity
17-03-2016	UKX	06-17-16	C	6.200		6.201	230,9	UKX 06/17/16 C6200 Equity
20-05-2016	UKX	06-17-16	C	6.150		6.156	137,9	UKX 06/17/16 C6150 Equity
23-05-2016	UKX	06-17-16	C	6.150		6.136	127,5	UKX 06/17/16 C6150 Equity
24-05-2016	UKX	06-17-16	C	6.200		6.219	144,8	UKX 06/17/16 C6200 Equity
25-05-2016	UKX	06-17-16	C	6.250		6.263	124,1	UKX 06/17/16 C6250 Equity
26-05-2016	UKX	06-17-16	C	6.250		6.266	121,6	UKX 06/17/16 C6250 Equity
27-05-2016	UKX	06-17-16	C	6.250		6.271	109	UKX 06/17/16 C6250 Equity
31-05-2016	UKX	06-17-16	C	6.250		6.231	87,1	UKX 06/17/16 C6250 Equity
01-06-2016	UKX	06-17-16	C	6.200		6.192	89,4	UKX 06/17/16 C6200 Equity
02-06-2016	UKX	06-17-16	C	6.200		6.186	90,9	UKX 06/17/16 C6200 Equity
03-06-2016	UKX	06-17-16	C	6.200		6.210	94,4	UKX 06/17/16 C6200 Equity
06-06-2016	UKX	06-17-16	C	6.250		6.273	109,9	UKX 06/17/16 C6250 Equity
07-06-2016	UKX	06-17-16	C	6.300		6.285	57,5	UKX 06/17/16 C6300 Equity
08-06-2016	UKX	06-17-16	C	6.300		6.302	65,4	UKX 06/17/16 C6300 Equity
09-06-2016	UKX	06-17-16	C	6.250		6.232	59,3	UKX 06/17/16 C6250 Equity
10-06-2016	UKX	06-17-16	C	6.100		6.116	114	UKX 06/17/16 C6100 Equity
13-06-2016	UKX	06-17-16	C	6.050		6.045	94,6	UKX 06/17/16 C6050 Equity
14-06-2016	UKX	06-17-16	C	5.900		5.924	104,7	UKX 06/17/16 C5900 Equity
15-06-2016	UKX	06-17-16	C	5.950		5.967	87,8	UKX 06/17/16 C5950 Equity
16-06-2016	UKX	06-17-16	C	5.950		5.950	43,2	UKX 06/17/16 C5950 Equity
17-06-2016	UKX	06-17-16	C	6.000		6.021	63,7	UKX 06/17/16 C6000 Equity
18-01-2016	UKX	07-15-16	C	5.800		5.780	392,2	UKX 07/15/16 C5800 Equity
18-04-2016	UKX	07-15-16	C	6.350		6.354	287	UKX 07/15/16 C6350 Equity
17-06-2016	UKX	07-15-16	C	6.000		6.021	284,1	UKX 07/15/16 C6000 Equity
20-06-2016	UKX	07-15-16	C	6.200		6.204	256,9	UKX 07/15/16 C6200 Equity
21-06-2016	UKX	07-15-16	C	6.250		6.227	251,5	UKX 07/15/16 C6250 Equity
22-06-2016	UKX	07-15-16	C	6.250		6.261	315,4	UKX 07/15/16 C6250 Equity
23-06-2016	UKX	07-15-16	C	6.350		6.338	222,9	UKX 07/15/16 C6350 Equity
24-06-2016	UKX	07-15-16	C	6.150		6.139	205	UKX 07/15/16 C6150 Equity
27-06-2016	UKX	07-15-16	C	6.000		5.982	187,6	UKX 07/15/16 C6000 Equity
28-06-2016	UKX	07-15-16	C	6.150		6.140	150,6	UKX 07/15/16 C6150 Equity
29-06-2016	UKX	07-15-16	C	6.350		6.360	148,9	UKX 07/15/16 C6350 Equity
30-06-2016	UKX	07-15-16	C	6.500		6.504	112,1	UKX 07/15/16 C6500 Equity
01-07-2016	UKX	07-15-16	C	6.600		6.578	99	UKX 07/15/16 C6600 Equity
04-07-2016	UKX	07-15-16	C	6.500		6.522	130,3	UKX 07/15/16 C6500 Equity
05-07-2016	UKX	07-15-16	C	6.550		6.545	107	UKX 07/15/16 C6550 Equity
06-07-2016	UKX	07-15-16	C	6.450		6.464	126,2	UKX 07/15/16 C6450 Equity
07-07-2016	UKX	07-15-16	C	6.550		6.534	89,7	UKX 07/15/16 C6550 Equity
08-07-2016	UKX	07-15-16	C	6.600		6.591	69,4	UKX 07/15/16 C6600 Equity
11-07-2016	UKX	07-15-16	C	6.700		6.683	54,5	UKX 07/15/16 C6700 Equity
12-07-2016	UKX	07-15-16	C	6.700		6.681	49,1	UKX 07/15/16 C6700 Equity
13-07-2016	UKX	07-15-16	C	6.650		6.670	95,6	UKX 07/15/16 C6650 Equity
14-07-2016	UKX	07-15-16	C	6.650		6.654	48	UKX 07/15/16 C6650 Equity
15-07-2016	UKX	07-15-16	C	6.650		6.669	0	UKX 07/15/16 C6650 Equity

Testing high volatility expectation trades – 2016 events

Strike prices for short butterfly spread – DAX index

DAX				
	-6%	6%	K1	K2
10750	-645	645	10105	11395
9900	-595	595	9305	10495
9900	-595	595	9305	10495
9850	-590	590	9260	10440
10050	-605	605	9445	10655
10200	-610	610	9590	10810
10250	-615	615	9635	10865
10300	-620	620	9680	10920
10350	-620	620	9730	10970
10250	-615	615	9635	10865
10200	-610	610	9590	10810
10200	-610	610	9590	10810
10100	-605	605	9495	10705
10100	-605	605	9495	10705
10300	-620	620	9680	10920
10200	-610	610	9590	10810
10100	-605	605	9495	10705
9850	-590	590	9260	10440
9650	-580	580	9070	10230
9500	-570	570	8930	10070
9600	-575	575	9025	10175
9550	-575	575	8975	10125
9650	-580	580	9070	10230
9500	-570	570	8930	10070
10100	-605	605	9495	10705
9650	-580	580	9070	10230
9950	-595	595	9355	10545
10000	-600	600	9400	10600
10050	-605	605	9445	10655
10250	-615	615	9635	10865
9550	-575	575	8975	10125
9250	-555	555	8695	9805
9450	-565	565	8885	10015
9600	-575	575	9025	10175
9700	-580	580	9120	10280
9800	-590	590	9210	10390
9700	-580	580	9120	10280
9550	-575	575	8975	10125
9350	-560	560	8790	9910
9400	-565	565	8835	9965

Testing high volatility expectation trades – 2016 events

DAX				
	-6%	6%	K1	K2
9650	-580	580	9070	10230
9850	-590	590	9260	10440
9950	-595	595	9355	10545
9950	-595	595	9355	10545
10050	-605	605	9445	10655
10050	-605	605	9445	10655

Strike prices for short butterfly spread – FTSE index

FTSE 100				
	-6%	6%	K1	K2
6100	-370	370	5730	6470
6200	-370	370	5830	6570
6150	-370	370	5780	6520
6150	-370	370	5780	6520
6200	-370	370	5830	6570
6250	-380	380	5870	6630
6250	-380	380	5870	6630
6250	-380	380	5870	6630
6250	-380	380	5870	6630
6200	-370	370	5830	6570
6200	-370	370	5830	6570
6200	-370	370	5830	6570
6250	-380	380	5870	6630
6300	-380	380	5920	6680
6300	-380	380	5920	6680
6250	-380	380	5870	6630
6100	-370	370	5730	6470
6050	-360	360	5690	6410
5900	-350	350	5550	6250
5950	-360	360	5590	6310
5950	-360	360	5590	6310
6000	-360	360	5640	6360
5800	-350	350	5450	6150
6350	-380	380	5970	6730
6000	-360	360	5640	6360
6200	-370	370	5830	6570
6250	-380	380	5870	6630

Testing high volatility expectation trades – 2016 events

FTSE 100				
	-6%	6%	K1	K2
6250	-380	380	5870	6630
6350	-380	380	5970	6730
6150	-370	370	5780	6520
6000	-360	360	5640	6360
6150	-370	370	5780	6520
6350	-380	380	5970	6730
6500	-390	390	6110	6890
6600	-400	400	6200	7000
6500	-390	390	6110	6890
6550	-390	390	6160	6940
6450	-390	390	6060	6840
6550	-390	390	6160	6940
6600	-400	400	6200	7000
6700	-400	400	6300	7100
6700	-400	400	6300	7100
6650	-400	400	6250	7050
6650	-400	400	6250	7050
6650	-400	400	6250	7050

Testing high volatility expectation trades – 2016 events

Closing prices for DAX 30 and Footsie 100 Indices

DAX		DAX		FTSE 100	
Date	Close	Date	Close	Date	Close
12-17-15	10.738,1	06-22-16	10.071,1	12-17-15	6.102,5
01-18-16	9.521,9	06-23-16	10.257,0	01-18-16	5.779,9
03-17-16	9.892,2	06-24-16	9.557,2	03-17-16	6.201,1
04-18-16	10.120,3	06-27-16	9.268,7	04-18-16	6.353,5
05-02-16	10.123,3	06-28-16	9.447,3	05-20-16	6.156,3
05-03-16	9.926,8	06-29-16	9.612,3	05-23-16	6.136,4
05-04-16	9.828,3	06-30-16	9.680,1	05-24-16	6.219,3
05-05-16	9.851,9	07-01-16	9.776,1	05-25-16	6.262,9
05-06-16	9.870,0	07-01-16	9.776,1	05-26-16	6.265,7
05-09-16	9.980,5	07-04-16	9.709,1	05-27-16	6.270,8
05-10-16	10.045,4	07-05-16	9.532,6	05-31-16	6.230,8
05-11-16	9.975,3	07-06-16	9.373,3	06-01-16	6.191,9
05-12-16	9.862,1	07-07-16	9.418,8	06-02-16	6.185,6
05-13-16	9.952,9	07-08-16	9.629,7	06-03-16	6.209,6
05-17-16	9.890,2	07-11-16	9.833,4	06-06-16	6.273,4
05-18-16	9.943,2	07-12-16	9.964,1	06-07-16	6.284,5
05-19-16	9.795,9	07-13-16	9.930,7	06-08-16	6.301,5
05-20-16	9.916,0	07-14-16	10.068,3	06-09-16	6.231,9
05-23-16	9.842,3	07-15-16	10.066,9	06-10-16	6.115,8
05-24-16	10.057,3			06-13-16	6.045,0
05-25-16	10.205,2			06-14-16	5.923,5
05-26-16	10.272,7			06-15-16	5.966,8
05-27-16	10.286,3			06-16-16	5.950,5
05-30-16	10.333,2			06-17-16	6.021,1
05-31-16	10.262,7			06-20-16	6.204,0
06-01-16	10.204,4			06-21-16	6.226,6
06-02-16	10.208,0			06-22-16	6.261,2
06-03-16	10.103,3			06-23-16	6.338,1
06-06-16	10.121,1			06-24-16	6.138,7
06-07-16	10.287,7			06-27-16	5.982,2
06-08-16	10.217,0			06-28-16	6.140,4
06-09-16	10.088,9			06-29-16	6.360,1
06-10-16	9.834,6			06-30-16	6.504,3
06-13-16	9.657,4			07-01-16	6.577,8
06-14-16	9.519,2			07-04-16	6.522,3
06-15-16	9.606,7			07-05-16	6.545,4
06-16-16	9.550,5			07-06-16	6.463,6
06-17-16	9.631,4			07-07-16	6.533,8
06-20-16	9.962,0			07-08-16	6.590,6
06-21-16	10.015,5			07-11-16	6.682,9
				07-12-16	6.680,7
				07-13-16	6.670,4
				07-14-16	6.654,5
				07-15-16	6.669,2

Testing high volatility expectation trades – 2016 events

Data collection – United States presidential Elections

Long straddle data for calls – S&P 500 index

Buy 1 ATM Call K

Buy 1 ATM Put K

LONG STRADDLE - S&P 500

Buy date	Asset	Maturity date	Call/Put	Strike Price	Spot Price	Option Price	Ticker
21-04-2016	SPX US	10-21-16	C	2090	2.091,0	-	SPX US 10/21/16 C2090 Equity
21-07-2016	SPX US	10-21-16	C	2165	2.165,0	-	SPX US 10/21/16 C2165 Equity
23-09-2016	SPX US	10-21-16	C	2165	2.164,7	24,32	SPX US 10/21/16 C2165 Equity
26-09-2016	SPX US	10-21-16	C	2145	2.146,1	29,1	SPX US 10/21/16 C2145 Equity
27-09-2016	SPX US	10-21-16	C	2160	2.159,9	23,06	SPX US 10/21/16 C2160 Equity
28-09-2016	SPX US	10-21-16	C	2170	2.171,4	22,5	SPX US 10/21/16 C2170 Equity
29-09-2016	SPX US	10-21-16	C	2150	2.151,1	29,08	SPX US 10/21/16 C2150 Equity
30-09-2016	SPX US	10-21-16	C	2170	2.168,3	21,4	SPX US 10/21/16 C2170 Equity
03-10-2016	SPX US	10-21-16	C	2160	2.161,2	21,8	SPX US 10/21/16 C2160 Equity
04-10-2016	SPX US	10-21-16	C	2150	2.150,5	22,2	SPX US 10/21/16 C2150 Equity
05-10-2016	SPX US	10-21-16	C	2160	2.159,7	19,35	SPX US 10/21/16 C2160 Equity
06-10-2016	SPX US	10-21-16	C	2160	2.160,8	20	SPX US 10/21/16 C2160 Equity
07-10-2016	SPX US	10-21-16	C	2155	2.153,7	17	SPX US 10/21/16 C2155 Equity
10-10-2016	SPX US	10-21-16	C	2165	2.163,7	13,4	SPX US 10/21/16 C2165 Equity
11-10-2016	SPX US	10-21-16	C	2135	2.136,7	20,2	SPX US 10/21/16 C2135 Equity
12-10-2016	SPX US	10-21-16	C	2140	2.139,2	16,21	SPX US 10/21/16 C2140 Equity
13-10-2016	SPX US	10-21-16	C	2135	2.132,6	15	SPX US 10/21/16 C2135 Equity
14-10-2016	SPX US	10-21-16	C	2135	2.133,0	12,9	SPX US 10/21/16 C2135 Equity
17-10-2016	SPX US	10-21-16	C	2125	2.126,5	14,5	SPX US 10/21/16 C2125 Equity
18-10-2016	SPX US	10-21-16	C	2140	2.139,6	8	SPX US 10/21/16 C2140 Equity
19-10-2016	SPX US	10-21-16	C	2145	2.144,3	5,84	SPX US 10/21/16 C2145 Equity
20-10-2016	SPX US	10-21-16	C	2140	2.141,3	5,6	SPX US 10/21/16 C2140 Equity
21-10-2016	SPX US	10-21-16	C	2140	2.141,2	-	SPX US 10/21/16 C2140 Equity
18-05-2016	SPX US	11-18-16	C	2050	2.048,0	-	SPX US 11/18/16 C2050 Equity
18-08-2016	SPX US	11-18-16	C	2185	2.187,0	-	SPX US 11/18/16 C2185 Equity
21-10-2016	SPX US	11-18-16	C	2140	2.141,2	26,6	SPX US 11/18/16 C2140 Equity
24-10-2016	SPX US	11-18-16	C	2150	2.151,3	23,52	SPX US 11/18/16 C2150 Equity
25-10-2016	SPX US	11-18-16	C	2145	2.143,2	24	SPX US 11/18/16 C2145 Equity
26-10-2016	SPX US	11-18-16	C	2140	2.139,4	26,7	SPX US 11/18/16 C2140 Equity
27-10-2016	SPX US	11-18-16	C	2135	2.133,0	26	SPX US 11/18/16 C2135 Equity
28-10-2016	SPX US	11-18-16	C	2125	2.126,4	32,4	SPX US 11/18/16 C2125 Equity
31-10-2016	SPX US	11-18-16	C	2125	2.126,1	30,77	SPX US 11/18/16 C2125 Equity
01-11-2016	SPX US	11-18-16	C	2110	2.111,7	32,5	SPX US 11/18/16 C2110 Equity
02-11-2016	SPX US	11-18-16	C	2100	2.097,9	31,1	SPX US 11/18/16 C2100 Equity
03-11-2016	SPX US	11-18-16	C	2090	2.088,7	34,4	SPX US 11/18/16 C2090 Equity
04-11-2016	SPX US	11-18-16	C	2085	2.085,2	37	SPX US 11/18/16 C2085 Equity
07-11-2016	SPX US	11-18-16	C	2130	2.131,5	30,8	SPX US 11/18/16 C2130 Equity
08-11-2016	SPX US	11-18-16	C	2140	2.139,6	25,5	SPX US 11/18/16 C2140 Equity
09-11-2016	SPX US	11-18-16	C	2165	2.163,3	15,94	SPX US 11/18/16 C2165 Equity
10-11-2016	SPX US	11-18-16	C	2165	2.167,5	16,5	SPX US 11/18/16 C2165 Equity
11-11-2016	SPX US	11-18-16	C	2165	2.164,4	12,49	SPX US 11/18/16 C2165 Equity
14-11-2016	SPX US	11-18-16	C	2165	2.164,2	9	SPX US 11/18/16 C2165 Equity
15-11-2016	SPX US	11-18-16	C	2180	2.180,4	8,6	SPX US 11/18/16 C2180 Equity
16-11-2016	SPX US	11-18-16	C	2175	2.176,9	5,7	SPX US 11/18/16 C2175 Equity
17-11-2016	SPX US	11-18-16	C	2185	2.187,1	4,5	SPX US 11/18/16 C2185 Equity
18-11-2016	SPX US	11-18-16	C	2180	2.181,9	-	SPX US 11/18/16 C2180 Equity

Testing high volatility expectation trades – 2016 events

LONG STRADDLE - S&P 500

Buy date	Asset	Maturity date	Call/Put	Strike Price	Spot Price	Option Price	Ticker
16-06-2016	SPX US	12-16-16	C	2080	2.078,0	-	SPX US 12/16/16 C2080 Equity
16-09-2016	SPX US	12-16-16	C	2140	2.139,0	-	58 SPX US 12/16/16 C2140 Equity
18-11-2016	SPX US	12-16-16	C	2180	2.181,9	26,1	SPX US 12/16/16 C2180 Equity
21-11-2016	SPX US	12-16-16	C	2200	2.198,2	19,7	SPX US 12/16/16 C2200 Equity
22-11-2016	SPX US	12-16-16	C	2205	2.202,9	20,8	SPX US 12/16/16 C2205 Equity
23-11-2016	SPX US	12-16-16	C	2205	2.204,7	20,1	SPX US 12/16/16 C2205 Equity
25-11-2016	SPX US	12-16-16	C	2215	2.213,4	19,16	SPX US 12/16/16 C2215 Equity
28-11-2016	SPX US	12-16-16	C	2200	2.201,7	21,5	SPX US 12/16/16 C2200 Equity
29-11-2016	SPX US	12-16-16	C	2205	2.204,7	20	SPX US 12/16/16 C2205 Equity
30-11-2016	SPX US	12-16-16	C	2200	2.198,8	21	SPX US 12/16/16 C2200 Equity
01-12-2016	SPX US	12-16-16	C	2190	2.191,1	23	SPX US 12/16/16 C2190 Equity
02-12-2016	SPX US	12-16-16	C	2190	2.191,9	21	SPX US 12/16/16 C2190 Equity
05-12-2016	SPX US	12-16-16	C	2205	2.204,7	14	SPX US 12/16/16 C2205 Equity
06-12-2016	SPX US	12-16-16	C	2210	2.212,2	14	SPX US 12/16/16 C2210 Equity
07-12-2016	SPX US	12-16-16	C	2240	2.241,4	13	SPX US 12/16/16 C2240 Equity
08-12-2016	SPX US	12-16-16	C	2245	2.246,2	15,57	SPX US 12/16/16 C2245 Equity
09-12-2016	SPX US	12-16-16	C	2260	2.259,5	11,53	SPX US 12/16/16 C2260 Equity
12-12-2016	SPX US	12-16-16	C	2255	2.257,0	11,5	SPX US 12/16/16 C2255 Equity
13-12-2016	SPX US	12-16-16	C	2270	2.271,7	11,6	SPX US 12/16/16 C2270 Equity
14-12-2016	SPX US	12-16-16	C	2255	2.253,3	8,33	SPX US 12/16/16 C2255 Equity
15-12-2016	SPX US	12-16-16	C	2260	2.262,0	6,5	SPX US 12/16/16 C2260 Equity
16-12-2016	SPX US	12-16-16	C	2260	2.258,1	-	SPX US 12/16/16 C2260 Equity

Long straddle data for puts – S&P 500 index

LONG STRADDLE - S&P 500

Buy date	Asset	Maturity date	Call/Put	Strike Price	Spot Price	Option Price	Ticker
21-04-2016	SPX US	10-21-16	P	2090	2.091,0	-	SPX US 10/21/16 P2090 Equity
21-07-2016	SPX US	10-21-16	P	2165	2.165,0	-	SPX US 10/21/16 P2165 Equity
23-09-2016	SPX US	10-21-16	P	2165	2.164,7	25	SPX US 10/21/16 P2165 Equity
26-09-2016	SPX US	10-21-16	P	2145	2.146,1	27,75	SPX US 10/21/16 P2145 Equity
27-09-2016	SPX US	10-21-16	P	2160	2.159,9	24,85	SPX US 10/21/16 P2160 Equity
28-09-2016	SPX US	10-21-16	P	2170	2.171,4	23	SPX US 10/21/16 P2170 Equity
29-09-2016	SPX US	10-21-16	P	2150	2.151,1	23,32	SPX US 10/21/16 P2150 Equity
30-09-2016	SPX US	10-21-16	P	2170	2.168,3	24	SPX US 10/21/16 P2170 Equity
03-10-2016	SPX US	10-21-16	P	2160	2.161,2	22,8	SPX US 10/21/16 P2160 Equity
04-10-2016	SPX US	10-21-16	P	2150	2.150,5	23	SPX US 10/21/16 P2150 Equity
05-10-2016	SPX US	10-21-16	P	2160	2.159,7	20,6	SPX US 10/21/16 P2160 Equity
06-10-2016	SPX US	10-21-16	P	2160	2.160,8	17,4	SPX US 10/21/16 P2160 Equity
07-10-2016	SPX US	10-21-16	P	2155	2.153,7	19,37	SPX US 10/21/16 P2155 Equity
10-10-2016	SPX US	10-21-16	P	2165	2.163,7	15,35	SPX US 10/21/16 P2165 Equity
11-10-2016	SPX US	10-21-16	P	2135	2.136,7	16	SPX US 10/21/16 P2135 Equity
12-10-2016	SPX US	10-21-16	P	2140	2.139,2	17,25	SPX US 10/21/16 P2140 Equity
13-10-2016	SPX US	10-21-16	P	2135	2.132,6	18,35	SPX US 10/21/16 P2135 Equity
14-10-2016	SPX US	10-21-16	P	2135	2.133,0	15	SPX US 10/21/16 P2135 Equity
17-10-2016	SPX US	10-21-16	P	2125	2.126,5	9,63	SPX US 10/21/16 P2125 Equity
18-10-2016	SPX US	10-21-16	P	2140	2.139,6	9,5	SPX US 10/21/16 P2140 Equity
19-10-2016	SPX US	10-21-16	P	2145	2.144,3	6,75	SPX US 10/21/16 P2145 Equity
20-10-2016	SPX US	10-21-16	P	2140	2.141,3	2,48	SPX US 10/21/16 P2140 Equity
21-10-2016	SPX US	10-21-16	P	2140	2.141,2	-	SPX US 10/21/16 P2140 Equity

Testing high volatility expectation trades – 2016 events

LONG STRADDLE - S&P 500							
Buy date	Asset	Maturity date	Call/Put	Strike Price	Spot Price	Option Price	Ticker
18-05-2016	SPX US	11-18-16	P	2050	2.048,0	-	SPX US 11/18/16 P2050 Equity
18-08-2016	SPX US	11-18-16	P	2185	2.187,0	-	SPX US 11/18/16 P2185 Equity
21-10-2016	SPX US	11-18-16	P	2140	2.141,2	29,1	SPX US 11/18/16 P2140 Equity
24-10-2016	SPX US	11-18-16	P	2150	2.151,3	26,9	SPX US 11/18/16 P2150 Equity
25-10-2016	SPX US	11-18-16	P	2145	2.143,2	28,5	SPX US 11/18/16 P2145 Equity
26-10-2016	SPX US	11-18-16	P	2140	2.139,4	29	SPX US 11/18/16 P2140 Equity
27-10-2016	SPX US	11-18-16	P	2135	2.133,0	33,2	SPX US 11/18/16 P2135 Equity
28-10-2016	SPX US	11-18-16	P	2125	2.126,4	31	SPX US 11/18/16 P2125 Equity
31-10-2016	SPX US	11-18-16	P	2125	2.126,1	31	SPX US 11/18/16 P2125 Equity
01-11-2016	SPX US	11-18-16	P	2110	2.111,7	33,23	SPX US 11/18/16 P2110 Equity
02-11-2016	SPX US	11-18-16	P	2100	2.097,9	36,75	SPX US 11/18/16 P2100 Equity
03-11-2016	SPX US	11-18-16	P	2090	2.088,7	38	SPX US 11/18/16 P2090 Equity
04-11-2016	SPX US	11-18-16	P	2085	2.085,2	3,65	SPX US 11/18/16 P2085 Equity
07-11-2016	SPX US	11-18-16	P	2130	2.131,5	29,22	SPX US 11/18/16 P2130 Equity
08-11-2016	SPX US	11-18-16	P	2140	2.139,6	29,5	SPX US 11/18/16 P2140 Equity
09-11-2016	SPX US	11-18-16	P	2165	2.163,3	17,73	SPX US 11/18/16 P2165 Equity
10-11-2016	SPX US	11-18-16	P	2165	2.167,5	15	SPX US 11/18/16 P2165 Equity
11-11-2016	SPX US	11-18-16	P	2165	2.164,4	13,98	SPX US 11/18/16 P2165 Equity
14-11-2016	SPX US	11-18-16	P	2165	2.164,2	12,3	SPX US 11/18/16 P2165 Equity
15-11-2016	SPX US	11-18-16	P	2180	2.180,4	7,5	SPX US 11/18/16 P2180 Equity
16-11-2016	SPX US	11-18-16	P	2175	2.176,9	5,36	SPX US 11/18/16 P2175 Equity
17-11-2016	SPX US	11-18-16	P	2185	2.187,1	3,42	SPX US 11/18/16 P2185 Equity
18-11-2016	SPX US	11-18-16	P	2180	2.181,9	-	SPX US 11/18/16 P2180 Equity
16-06-2016	SPX US	12-16-16	P	2080	2.078,0	-	SPX US 12/16/16 P2080 Equity
16-09-2016	SPX US	12-16-16	P	2140	2.139,0	66,5	SPX US 12/16/16 P2140 Equity
18-11-2016	SPX US	12-16-16	P	2180	2.181,9	26	SPX US 12/16/16 P2180 Equity
21-11-2016	SPX US	12-16-16	P	2200	2.198,2	26	SPX US 12/16/16 P2200 Equity
22-11-2016	SPX US	12-16-16	P	2205	2.202,9	24,5	SPX US 12/16/16 P2205 Equity
23-11-2016	SPX US	12-16-16	P	2205	2.204,7	24	SPX US 12/16/16 P2205 Equity
25-11-2016	SPX US	12-16-16	P	2215	2.213,4	23,1	SPX US 12/16/16 P2215 Equity
28-11-2016	SPX US	12-16-16	P	2200	2.201,7	21	SPX US 12/16/16 P2200 Equity
29-11-2016	SPX US	12-16-16	P	2205	2.204,7	22	SPX US 12/16/16 P2205 Equity
30-11-2016	SPX US	12-16-16	P	2200	2.198,8	21	SPX US 12/16/16 P2200 Equity
01-12-2016	SPX US	12-16-16	P	2190	2.191,1	21	SPX US 12/16/16 P2190 Equity
02-12-2016	SPX US	12-16-16	P	2190	2.191,9	21	SPX US 12/16/16 P2190 Equity
05-12-2016	SPX US	12-16-16	P	2205	2.204,7	16	SPX US 12/16/16 P2205 Equity
06-12-2016	SPX US	12-16-16	P	2210	2.212,2	13	SPX US 12/16/16 P2210 Equity
07-12-2016	SPX US	12-16-16	P	2240	2.241,4	14	SPX US 12/16/16 P2240 Equity
08-12-2016	SPX US	12-16-16	P	2245	2.246,2	12,85	SPX US 12/16/16 P2245 Equity
09-12-2016	SPX US	12-16-16	P	2260	2.259,5	11,3	SPX US 12/16/16 P2260 Equity
12-12-2016	SPX US	12-16-16	P	2255	2.257,0	9,3	SPX US 12/16/16 P2255 Equity
13-12-2016	SPX US	12-16-16	P	2270	2.271,7	8	SPX US 12/16/16 P2270 Equity
14-12-2016	SPX US	12-16-16	P	2255	2.253,3	6,7	SPX US 12/16/16 P2255 Equity
15-12-2016	SPX US	12-16-16	P	2260	2.262,0	3	SPX US 12/16/16 P2260 Equity
16-12-2016	SPX US	12-16-16	P	2260	2.258,1	-	SPX US 12/16/16 P2260 Equity

Testing high volatility expectation trades – 2016 events

Long strangle data for calls – S&P 500 index

Buy 1 OTM Call K2

Buy 1 ITM Put K1

LONG STRANGLE - S&P 500

3%

K2

Buy date	Asset	Maturity date	Call/Put	Strike Price	Spot Price	Option Price	Ticker
21-04-2016	SPX US	10-21-16	C	2155	2.091,0	-	SPX US 10/21/16 C2155 Equity
21-07-2016	SPX US	10-21-16	C	2230	2.165,0	18,1	SPX US 10/21/16 C2230 Equity
23-09-2016	SPX US	10-21-16	C	2230	2.164,7	1,35	SPX US 10/21/16 C2230 Equity
26-09-2016	SPX US	10-21-16	C	2210	2.146,1	2,7	SPX US 10/21/16 C2210 Equity
27-09-2016	SPX US	10-21-16	C	2225	2.159,9	1,2	SPX US 10/21/16 C2225 Equity
28-09-2016	SPX US	10-21-16	C	2235	2.171,4	0,81	SPX US 10/21/16 C2235 Equity
29-09-2016	SPX US	10-21-16	C	2215	2.151,1	2,1	SPX US 10/21/16 C2215 Equity
30-09-2016	SPX US	10-21-16	C	2235	2.168,3	0,7	SPX US 10/21/16 C2235 Equity
03-10-2016	SPX US	10-21-16	C	2225	2.161,2	0,7	SPX US 10/21/16 C2225 Equity
04-10-2016	SPX US	10-21-16	C	2215	2.150,5	0,79	SPX US 10/21/16 C2215 Equity
05-10-2016	SPX US	10-21-16	C	2225	2.159,7	0,52	SPX US 10/21/16 C2225 Equity
06-10-2016	SPX US	10-21-16	C	2225	2.160,8	0,3	SPX US 10/21/16 C2225 Equity
07-10-2016	SPX US	10-21-16	C	2220	2.153,7	0,25	SPX US 10/21/16 C2220 Equity
10-10-2016	SPX US	10-21-16	C	2230	2.163,7	0,13	SPX US 10/21/16 C2230 Equity
11-10-2016	SPX US	10-21-16	C	2200	2.136,7	0,4	SPX US 10/21/16 C2200 Equity
12-10-2016	SPX US	10-21-16	C	2205	2.139,2	0,28	SPX US 10/21/16 C2205 Equity
13-10-2016	SPX US	10-21-16	C	2200	2.132,6	0,16	SPX US 10/21/16 C2200 Equity
14-10-2016	SPX US	10-21-16	C	2200	2.133,0	0,1	SPX US 10/21/16 C2200 Equity
17-10-2016	SPX US	10-21-16	C	2190	2.126,5	0,05	SPX US 10/21/16 C2190 Equity
18-10-2016	SPX US	10-21-16	C	2205	2.139,6	0,1	SPX US 10/21/16 C2205 Equity
19-10-2016	SPX US	10-21-16	C	2210	2.144,3	0,05	SPX US 10/21/16 C2210 Equity
20-10-2016	SPX US	10-21-16	C	2205	2.141,3	0,05	SPX US 10/21/16 C2205 Equity
21-10-2016	SPX US	10-21-16	C	2205	2.141,2	-	SPX US 10/21/16 C2205 Equity
18-05-2016	SPX US	11-18-16	C	2110	2.048,0	-	SPX US 11/18/16 C2110 Equity
18-08-2016	SPX US	11-18-16	C	2250	2.187,0	17,35	SPX US 11/18/16 C2250 Equity
21-10-2016	SPX US	11-18-16	C	2205	2.141,2	2,34	SPX US 11/18/16 C2205 Equity
24-10-2016	SPX US	11-18-16	C	2215	2.151,3	1,48	SPX US 11/18/16 C2215 Equity
25-10-2016	SPX US	11-18-16	C	2210	2.143,2	1,85	SPX US 11/18/16 C2210 Equity
26-10-2016	SPX US	11-18-16	C	2205	2.139,4	2,35	SPX US 11/18/16 C2205 Equity
27-10-2016	SPX US	11-18-16	C	2200	2.133,0	2,55	SPX US 11/18/16 C2200 Equity
28-10-2016	SPX US	11-18-16	C	2190	2.126,4	3,85	SPX US 11/18/16 C2190 Equity
31-10-2016	SPX US	11-18-16	C	2190	2.126,1	3,75	SPX US 11/18/16 C2190 Equity
01-11-2016	SPX US	11-18-16	C	2175	2.111,7	5	SPX US 11/18/16 C2175 Equity
02-11-2016	SPX US	11-18-16	C	2165	2.097,9	5,5	SPX US 11/18/16 C2165 Equity
03-11-2016	SPX US	11-18-16	C	2155	2.088,7	6,55	SPX US 11/18/16 C2155 Equity
04-11-2016	SPX US	11-18-16	C	2150	2.085,2	7,41	SPX US 11/18/16 C2150 Equity
07-11-2016	SPX US	11-18-16	C	2195	2.131,5	2,4	SPX US 11/18/16 C2195 Equity
08-11-2016	SPX US	11-18-16	C	2205	2.139,6	1,99	SPX US 11/18/16 C2205 Equity
09-11-2016	SPX US	11-18-16	C	2230	2.163,3	0,4	SPX US 11/18/16 C2230 Equity
10-11-2016	SPX US	11-18-16	C	2230	2.167,5	0,39	SPX US 11/18/16 C2230 Equity
11-11-2016	SPX US	11-18-16	C	2230	2.164,4	0,3	SPX US 11/18/16 C2230 Equity
14-11-2016	SPX US	11-18-16	C	2190	2.164,2	1,15	SPX US 11/18/16 C2190 Equity
15-11-2016	SPX US	11-18-16	C	2205	2.180,4	1,1	SPX US 11/18/16 C2205 Equity
16-11-2016	SPX US	11-18-16	C	2210	2.176,9	0,25	SPX US 11/18/16 C2210 Equity
17-11-2016	SPX US	11-18-16	C	2205	2.187,1	0,35	SPX US 11/18/16 C2205 Equity
18-11-2016	SPX US	11-18-16	C	2205	2.181,9	-	SPX US 11/18/16 C2205 Equity

Testing high volatility expectation trades – 2016 events

LONG STRANGLE - S&P 500

3%

K2

Buy date	Asset	Maturity date	Call/Put	Strike Price	Spot Price	Option Price	Ticker
16-06-2016	SPX US	12-16-16	C	2140	2.078,0	-	SPX US 12/16/16 C2140 Equity
16-09-2016	SPX US	12-16-16	C	2205	2.139,0	-	SPX US 12/16/16 C2205 Equity
18-11-2016	SPX US	12-16-16	C	2245	2.181,9	2,85	SPX US 12/16/16 C2245 Equity
21-11-2016	SPX US	12-16-16	C	2265	2.198,2	1,5	SPX US 12/16/16 C2265 Equity
22-11-2016	SPX US	12-16-16	C	2270	2.202,9	1,55	SPX US 12/16/16 C2270 Equity
23-11-2016	SPX US	12-16-16	C	2270	2.204,7	1,63	SPX US 12/16/16 C2270 Equity
25-11-2016	SPX US	12-16-16	C	2280	2.213,4	1,33	SPX US 12/16/16 C2280 Equity
28-11-2016	SPX US	12-16-16	C	2265	2.201,7	1,55	SPX US 12/16/16 C2265 Equity
29-11-2016	SPX US	12-16-16	C	2270	2.204,7	1,11	SPX US 12/16/16 C2270 Equity
30-11-2016	SPX US	12-16-16	C	2265	2.198,8	1,3	SPX US 12/16/16 C2265 Equity
01-12-2016	SPX US	12-16-16	C	2255	2.191,1	1,55	SPX US 12/16/16 C2255 Equity
02-12-2016	SPX US	12-16-16	C	2255	2.191,9	1,24	SPX US 12/16/16 C2255 Equity
05-12-2016	SPX US	12-16-16	C	2270	2.204,7	0,4	SPX US 12/16/16 C2270 Equity
06-12-2016	SPX US	12-16-16	C	2275	2.212,2	0,3	SPX US 12/16/16 C2275 Equity
07-12-2016	SPX US	12-16-16	C	2305	2.241,4	0,7	SPX US 12/16/16 C2305 Equity
08-12-2016	SPX US	12-16-16	C	2310	2.246,2	0,63	SPX US 12/16/16 C2310 Equity
09-12-2016	SPX US	12-16-16	C	2330	2.259,5	0,55	SPX US 12/16/16 C2330 Equity
12-12-2016	SPX US	12-16-16	C	2325	2.257,0	0,2	SPX US 12/16/16 C2325 Equity
13-12-2016	SPX US	12-16-16	C	2340	2.271,7	0,33	SPX US 12/16/16 C2340 Equity
14-12-2016	SPX US	12-16-16	C	2325	2.253,3	0,15	SPX US 12/16/16 C2325 Equity
15-12-2016	SPX US	12-16-16	C	2330	2.262,0	0,05	SPX US 12/16/16 C2330 Equity
16-12-2016	SPX US	12-16-16	C	2330	2.258,1	-	SPX US 12/16/16 C2330 Equity

Long strangle data for puts – S&P 500 index

LONG STRANGLE - S&P 500

-3%

K1

Buy date	Asset	Maturity date	Call/Put	Strike Price	Spot Price	Option Price	Ticker
21-04-2016	SPX US	10-21-16	P	2025	2.091,0	-	SPX US 10/21/16 P2025 Equity
21-07-2016	SPX US	10-21-16	P	2100	2.165,0	38,1	SPX US 10/21/16 P2100 Equity
23-09-2016	SPX US	10-21-16	P	2100	2.164,7	9,5	SPX US 10/21/16 P2100 Equity
26-09-2016	SPX US	10-21-16	P	2080	2.146,1	12	SPX US 10/21/16 P2080 Equity
27-09-2016	SPX US	10-21-16	P	2095	2.159,9	8,98	SPX US 10/21/16 P2095 Equity
28-09-2016	SPX US	10-21-16	P	2105	2.171,4	7,65	SPX US 10/21/16 P2105 Equity
29-09-2016	SPX US	10-21-16	P	2085	2.151,1	10,3	SPX US 10/21/16 P2085 Equity
30-09-2016	SPX US	10-21-16	P	2105	2.168,3	8,75	SPX US 10/21/16 P2105 Equity
03-10-2016	SPX US	10-21-16	P	2095	2.161,2	7,84	SPX US 10/21/16 P2095 Equity
04-10-2016	SPX US	10-21-16	P	2085	2.150,5	6,95	SPX US 10/21/16 P2085 Equity
05-10-2016	SPX US	10-21-16	P	2095	2.159,7	5,37	SPX US 10/21/16 P2095 Equity
06-10-2016	SPX US	10-21-16	P	2095	2.160,8	4,03	SPX US 10/21/16 P2095 Equity
07-10-2016	SPX US	10-21-16	P	2090	2.153,7	4,21	SPX US 10/21/16 P2090 Equity
10-10-2016	SPX US	10-21-16	P	2100	2.163,7	2,49	SPX US 10/21/16 P2100 Equity
11-10-2016	SPX US	10-21-16	P	2070	2.136,7	3,06	SPX US 10/21/16 P2070 Equity
12-10-2016	SPX US	10-21-16	P	2075	2.139,2	2,7	SPX US 10/21/16 P2075 Equity
13-10-2016	SPX US	10-21-16	P	2070	2.132,6	2,49	SPX US 10/21/16 P2070 Equity
14-10-2016	SPX US	10-21-16	P	2070	2.133,0	1,5	SPX US 10/21/16 P2070 Equity
17-10-2016	SPX US	10-21-16	P	2060	2.126,5	0,6	SPX US 10/21/16 P2060 Equity
18-10-2016	SPX US	10-21-16	P	2075	2.139,6	0,25	SPX US 10/21/16 P2075 Equity
19-10-2016	SPX US	10-21-16	P	2080	2.144,3	0,2	SPX US 10/21/16 P2080 Equity
20-10-2016	SPX US	10-21-16	P	2075	2.141,3	0,1	SPX US 10/21/16 P2075 Equity
21-10-2016	SPX US	10-21-16	P	2075	2.141,2	-	SPX US 10/21/16 P2075 Equity

Testing high volatility expectation trades – 2016 events

LONG STRANGLE - S&P 500

-3%

K1

Buy date	Asset	Maturity date	Call/Put	Strike Price	Spot Price	Option Price	Ticker
18-05-2016	SPX US	11-18-16	P	1990	2.048,0	-	SPX US 11/18/16 P1990 Equity
18-08-2016	SPX US	11-18-16	P	2120	2.187,0	37,8	SPX US 11/18/16 P2120 Equity
21-10-2016	SPX US	11-18-16	P	2075	2.141,2	11,7	SPX US 11/18/16 P2075 Equity
24-10-2016	SPX US	11-18-16	P	2085	2.151,3	10,3	SPX US 11/18/16 P2085 Equity
25-10-2016	SPX US	11-18-16	P	2080	2.143,2	11,35	SPX US 11/18/16 P2080 Equity
26-10-2016	SPX US	11-18-16	P	2075	2.139,4	12,5	SPX US 11/18/16 P2075 Equity
27-10-2016	SPX US	11-18-16	P	2070	2.133,0	13,7	SPX US 11/18/16 P2070 Equity
28-10-2016	SPX US	11-18-16	P	2060	2.126,4	13,15	SPX US 11/18/16 P2060 Equity
31-10-2016	SPX US	11-18-16	P	2060	2.126,1	14	SPX US 11/18/16 P2060 Equity
01-11-2016	SPX US	11-18-16	P	2045	2.111,7	15,35	SPX US 11/18/16 P2045 Equity
02-11-2016	SPX US	11-18-16	P	2035	2.097,9	15,31	SPX US 11/18/16 P2035 Equity
03-11-2016	SPX US	11-18-16	P	2025	2.088,7	18,76	SPX US 11/18/16 P2025 Equity
04-11-2016	SPX US	11-18-16	P	2020	2.085,2	19,3	SPX US 11/18/16 P2020 Equity
07-11-2016	SPX US	11-18-16	P	2065	2.131,5	14,4	SPX US 11/18/16 P2065 Equity
08-11-2016	SPX US	11-18-16	P	2075	2.139,6	13,97	SPX US 11/18/16 P2075 Equity
09-11-2016	SPX US	11-18-16	P	2100	2.163,3	4,4	SPX US 11/18/16 P2100 Equity
10-11-2016	SPX US	11-18-16	P	2100	2.167,5	3,29	SPX US 11/18/16 P2100 Equity
11-11-2016	SPX US	11-18-16	P	2100	2.164,4	2,25	SPX US 11/18/16 P2100 Equity
14-11-2016	SPX US	11-18-16	P	2060	2.126,5	0,55	SPX US 11/18/16 P2060 Equity
15-11-2016	SPX US	11-18-16	P	2075	2.139,6	0,25	SPX US 11/18/16 P2075 Equity
16-11-2016	SPX US	11-18-16	P	2080	2.144,3	0,25	SPX US 11/18/16 P2080 Equity
17-11-2016	SPX US	11-18-16	P	2075	2.141,3	0,1	SPX US 11/18/16 P2075 Equity
18-11-2016	SPX US	11-18-16	P	2075	2.141,2	-	SPX US 11/18/16 P2075 Equity
16-06-2016	SPX US	12-16-16	P	2020	2.078,0	-	SPX US 12/16/16 P2020 Equity
16-09-2016	SPX US	12-16-16	P	2075	2.139,0	45,4	SPX US 12/16/16 P2075 Equity
18-11-2016	SPX US	12-16-16	P	2115	2.181,9	9,52	SPX US 12/16/16 P2115 Equity
21-11-2016	SPX US	12-16-16	P	2135	2.198,2	8,37	SPX US 12/16/16 P2135 Equity
22-11-2016	SPX US	12-16-16	P	2140	2.202,9	7,95	SPX US 12/16/16 P2140 Equity
23-11-2016	SPX US	12-16-16	P	2140	2.204,7	7,7	SPX US 12/16/16 P2140 Equity
25-11-2016	SPX US	12-16-16	P	2150	2.213,4	7,05	SPX US 12/16/16 P2150 Equity
28-11-2016	SPX US	12-16-16	P	2135	2.201,7	6,45	SPX US 12/16/16 P2135 Equity
29-11-2016	SPX US	12-16-16	P	2140	2.204,7	6,4	SPX US 12/16/16 P2140 Equity
30-11-2016	SPX US	12-16-16	P	2135	2.198,8	6,3	SPX US 12/16/16 P2135 Equity
01-12-2016	SPX US	12-16-16	P	2125	2.191,1	6,2	SPX US 12/16/16 P2125 Equity
02-12-2016	SPX US	12-16-16	P	2125	2.191,9	6	SPX US 12/16/16 P2125 Equity
05-12-2016	SPX US	12-16-16	P	2140	2.204,7	2,73	SPX US 12/16/16 P2140 Equity
06-12-2016	SPX US	12-16-16	P	2145	2.212,2	1,8	SPX US 12/16/16 P2145 Equity
07-12-2016	SPX US	12-16-16	P	2175	2.241,4	1,85	SPX US 12/16/16 P2175 Equity
08-12-2016	SPX US	12-16-16	P	2180	2.246,2	1,72	SPX US 12/16/16 P2180 Equity
09-12-2016	SPX US	12-16-16	P	2190	2.259,5	0,91	SPX US 12/16/16 P2190 Equity
12-12-2016	SPX US	12-16-16	P	2185	2.257,0	0,75	SPX US 12/16/16 P2185 Equity
13-12-2016	SPX US	12-16-16	P	2200	2.271,7	0,5	SPX US 12/16/16 P2200 Equity
14-12-2016	SPX US	12-16-16	P	2185	2.253,3	0,6	SPX US 12/16/16 P2185 Equity
15-12-2016	SPX US	12-16-16	P	2190	2.262,0	0,25	SPX US 12/16/16 P2190 Equity
16-12-2016	SPX US	12-16-16	P	2190	2.258,1	-	SPX US 12/16/16 P2190 Equity

Testing high volatility expectation trades – 2016 events

Strike prices for long strangle – S&P 500

SPX US				
	-3%	3%	K1	K2
2090	-65	65	2025	2155
2165	-65	65	2100	2230
2165	-65	65	2100	2230
2145	-65	65	2080	2210
2160	-65	65	2095	2225
2170	-65	65	2105	2235
2150	-65	65	2085	2215
2170	-65	65	2105	2235
2160	-65	65	2095	2225
2150	-65	65	2085	2215
2160	-65	65	2095	2225
2160	-65	65	2095	2225
2155	-65	65	2090	2220
2165	-65	65	2100	2230
2135	-65	65	2070	2200
2140	-65	65	2075	2205
2135	-65	65	2070	2200
2135	-65	65	2070	2200
2125	-65	65	2060	2190
2140	-65	65	2075	2205
2145	-65	65	2080	2210
2140	-65	65	2075	2205
2140	-65	65	2075	2205
2050	-60	60	1990	2110
2185	-65	65	2120	2250
2140	-65	65	2075	2205
2150	-65	65	2085	2215
2145	-65	65	2080	2210
2140	-65	65	2075	2205
2135	-65	65	2070	2200
2125	-65	65	2060	2190
2125	-65	65	2060	2190
2110	-65	65	2045	2175
2100	-65	65	2035	2165
2090	-65	65	2025	2155
2085	-65	65	2020	2150
2130	-65	65	2065	2195
2140	-65	65	2075	2205
2165	-65	65	2100	2230
2165	-65	65	2100	2230
2165	-65	65	2100	2230

Testing high volatility expectation trades – 2016 events

SPX US				
	-3%	3%	K1	K2
2125	-65	65	2060	2190
2140	-65	65	2075	2205
2145	-65	65	2080	2210
2140	-65	65	2075	2205
2140	-65	65	2075	2205
2080	-60	60	2020	2140
2140	-65	65	2075	2205
2180	-65	65	2115	2245
2200	-65	65	2135	2265
2205	-65	65	2140	2270
2205	-65	65	2140	2270
2215	-65	65	2150	2280
2200	-65	65	2135	2265
2205	-65	65	2140	2270
2200	-65	65	2135	2265
2190	-65	65	2125	2255
2190	-65	65	2125	2255
2205	-65	65	2140	2270
2210	-65	65	2145	2275
2240	-65	65	2175	2305
2245	-65	65	2180	2310
2260	-70	70	2190	2330
2255	-70	70	2185	2325
2270	-70	70	2200	2340
2255	-70	70	2185	2325
2260	-70	70	2190	2330
2260	-70	70	2190	2330

Testing high volatility expectation trades – 2016 events

Short butterfly spread data for K1 (strike 1) – S&P 500 index

Sell 1 ITM Call K1
 Sell 1 OTM Call K2
 Buy 2 ATM Call K'

SHORT BUTTERFLY SPREAD WITH CALLS - S&P 500

-4,00%

K1

Buy date	Asset	Maturity date	Call/Put	Strike Price	Spot Price	Option Price	Ticker
21-04-2016	SPX US	10-21-16	C	2005	2.091,0	-	SPX US 10/21/16 C2005 Equity
19-07-2016	SPX US	10-21-16	C	2080	2.163,8	107,45	SPX US 10/21/16 C2080 Equity
23-09-2016	SPX US	10-21-16	C	2080	2.164,7	92,2	SPX US 10/21/16 C2080 Equity
26-09-2016	SPX US	10-21-16	C	2060	2.146,1	93,9	SPX US 10/21/16 C2060 Equity
27-09-2016	SPX US	10-21-16	C	2075	2.159,9	87,25	SPX US 10/21/16 C2075 Equity
28-09-2016	SPX US	10-21-16	C	2085	2.171,4	-	SPX US 10/21/16 C2085 Equity
29-09-2016	SPX US	10-21-16	C	2065	2.151,1	-	SPX US 10/21/16 C2065 Equity
30-09-2016	SPX US	10-21-16	C	2085	2.168,3	89,7	SPX US 10/21/16 C2085 Equity
03-10-2016	SPX US	10-21-16	C	2075	2.161,2	85,55	SPX US 10/21/16 C2075 Equity
04-10-2016	SPX US	10-21-16	C	2065	2.150,5	-	SPX US 10/21/16 C2065 Equity
05-10-2016	SPX US	10-21-16	C	2075	2.159,7	87,73	SPX US 10/21/16 C2075 Equity
06-10-2016	SPX US	10-21-16	C	2075	2.160,8	86,6	SPX US 10/21/16 C2075 Equity
07-10-2016	SPX US	10-21-16	C	2070	2.153,7	89,2	SPX US 10/21/16 C2070 Equity
10-10-2016	SPX US	10-21-16	C	2080	2.163,7	89,3	SPX US 10/21/16 C2080 Equity
11-10-2016	SPX US	10-21-16	C	2050	2.136,7	90,4	SPX US 10/21/16 C2050 Equity
12-10-2016	SPX US	10-21-16	C	2055	2.139,2	-	SPX US 10/21/16 C2055 Equity
13-10-2016	SPX US	10-21-16	C	2050	2.132,6	88,55	SPX US 10/21/16 C2050 Equity
14-10-2016	SPX US	10-21-16	C	2050	2.133,0	85,66	SPX US 10/21/16 C2050 Equity
17-10-2016	SPX US	10-21-16	C	2040	2.126,5	-	SPX US 10/21/16 C2040 Equity
18-10-2016	SPX US	10-21-16	C	2055	2.139,6	85,72	SPX US 10/21/16 C2055 Equity
19-10-2016	SPX US	10-21-16	C	2060	2.144,3	85,29	SPX US 10/21/16 C2060 Equity
20-10-2016	SPX US	10-21-16	C	2055	2.141,3	88,63	SPX US 10/21/16 C2055 Equity
21-10-2016	SPX US	10-21-16	C	2055	2.141,2	-	SPX US 10/21/16 C2055 Equity
18-05-2016	SPX US	11-18-16	C	1970	2.048,0	-	SPX US 11/18/16 C1970 Equity
18-08-2016	SPX US	11-18-16	C	2100	2.187,0	108,2	SPX US 11/18/16 C2100 Equity
19-10-2016	SPX US	11-18-16	C	2055	2.144,3	96,4	SPX US 11/18/16 C2055 Equity
24-10-2016	SPX US	11-18-16	C	2065	2.151,3	-	SPX US 11/18/16 C2065 Equity
25-10-2016	SPX US	11-18-16	C	2060	2.143,2	88,5	SPX US 11/18/16 C2060 Equity
26-10-2016	SPX US	11-18-16	C	2055	2.139,4	-	SPX US 11/18/16 C2055 Equity
27-10-2016	SPX US	11-18-16	C	2050	2.133,0	87,8	SPX US 11/18/16 C2050 Equity
28-10-2016	SPX US	11-18-16	C	2040	2.126,4	94,1	SPX US 11/18/16 C2040 Equity
31-10-2016	SPX US	11-18-16	C	2040	2.126,1	95,95	SPX US 11/18/16 C2040 Equity
01-11-2016	SPX US	11-18-16	C	2025	2.111,7	97,1	SPX US 11/18/16 C2025 Equity
02-11-2016	SPX US	11-18-16	C	2015	2.097,9	93,6	SPX US 11/18/16 C2015 Equity
03-11-2016	SPX US	11-18-16	C	2005	2.088,7	98,28	SPX US 11/18/16 C2005 Equity
04-11-2016	SPX US	11-18-16	C	2000	2.085,2	99	SPX US 11/18/16 C2000 Equity
07-11-2016	SPX US	11-18-16	C	2045	2.131,5	82,7	SPX US 11/18/16 C2045 Equity
08-11-2016	SPX US	11-18-16	C	2055	2.139,6	-	SPX US 11/18/16 C2055 Equity
09-11-2016	SPX US	11-18-16	C	2080	2.163,3	86,95	SPX US 11/18/16 C2080 Equity
10-11-2016	SPX US	11-18-16	C	2080	2.167,5	99,35	SPX US 11/18/16 C2080 Equity
11-11-2016	SPX US	11-18-16	C	2080	2.164,4	82,6	SPX US 11/18/16 C2080 Equity
14-11-2016	SPX US	11-18-16	C	2040	2.164,2	126,2	SPX US 11/18/16 C2040 Equity
15-11-2016	SPX US	11-18-16	C	2055	2.180,4	116,03	SPX US 11/18/16 C2055 Equity
16-11-2016	SPX US	11-18-16	C	2060	2.176,9	-	SPX US 11/18/16 C2060 Equity
17-11-2016	SPX US	11-18-16	C	2055	2.187,1	131,5	SPX US 11/18/16 C2055 Equity
18-11-2016	SPX US	11-18-16	C	2055	2.181,9	-	SPX US 11/18/16 C2055 Equity

Testing high volatility expectation trades – 2016 events

SHORT BUTTERFLY SPREAD WITH CALLS - S&P 500

-4,00%

K1

Buy date	Asset	Maturity date	Call/Put	Strike Price	Spot Price	Option Price	Ticker
16-06-2016	SPX US	12-16-16	C	1995	2.078,0	-	SPX US 12/16/16 C1995 Equity
15-09-2016	SPX US	12-16-16	C	2055	2.147,3	125,2	SPX US 12/16/16 C2055 Equity
18-11-2016	SPX US	12-16-16	C	2095	2.181,9	92,4	SPX US 12/16/16 C2095 Equity
21-11-2016	SPX US	12-16-16	C	2110	2.198,2	88,92	SPX US 12/16/16 C2110 Equity
22-11-2016	SPX US	12-16-16	C	2115	2.202,9	-	SPX US 12/16/16 C2115 Equity
23-11-2016	SPX US	12-16-16	C	2115	2.204,7	85	SPX US 12/16/16 C2115 Equity
25-11-2016	SPX US	12-16-16	C	2125	2.213,4	89,5	SPX US 12/16/16 C2125 Equity
28-11-2016	SPX US	12-16-16	C	2110	2.201,7	97,8	SPX US 12/16/16 C2110 Equity
29-11-2016	SPX US	12-16-16	C	2115	2.204,7	97	SPX US 12/16/16 C2115 Equity
30-11-2016	SPX US	12-16-16	C	2110	2.198,8	97,01	SPX US 12/16/16 C2110 Equity
01-12-2016	SPX US	12-16-16	C	2100	2.191,1	91,13	SPX US 12/16/16 C2100 Equity
02-12-2016	SPX US	12-16-16	C	2100	2.191,9	94,86	SPX US 12/16/16 C2100 Equity
05-12-2016	SPX US	12-16-16	C	2115	2.204,7	92,7	SPX US 12/16/16 C2115 Equity
06-12-2016	SPX US	12-16-16	C	2120	2.212,2	89,5	SPX US 12/16/16 C2120 Equity
07-12-2016	SPX US	12-16-16	C	2150	2.241,4	90,5	SPX US 12/16/16 C2150 Equity
08-12-2016	SPX US	12-16-16	C	2155	2.246,2	89,6	SPX US 12/16/16 C2155 Equity
09-12-2016	SPX US	12-16-16	C	2170	2.259,5	88,6	SPX US 12/16/16 C2170 Equity
12-12-2016	SPX US	12-16-16	C	2165	2.257,0	92,57	SPX US 12/16/16 C2165 Equity
13-12-2016	SPX US	12-16-16	C	2180	2.271,7	92	SPX US 12/16/16 C2180 Equity
14-12-2016	SPX US	12-16-16	C	2165	2.253,3	89,37	SPX US 12/16/16 C2165 Equity
15-12-2016	SPX US	12-16-16	C	2170	2.262,0	94,06	SPX US 12/16/16 C2170 Equity
16-12-2016	SPX US	12-16-16	C	2170	2.258,1	-	SPX US 12/16/16 C2170 Equity

Short butterfly spread data for K2 (strike 2) – S&P 500 index

SHORT BUTTERFLY SPREAD WITH CALLS - S&P 500

4,00%

K2

Buy date	Asset	Maturity date	Call/Put	Strike Price	Spot Price	Option Price	Ticker
21-04-2016	SPX US	10-21-16	C	2175	2.091,0	-	SPX US 10/21/16 C2175 Equity
21-07-2016	SPX US	10-21-16	C	2250	2.165,0	12,25	SPX US 10/21/16 C2250 Equity
23-09-2016	SPX US	10-21-16	C	2250	2.164,7	0,55	SPX US 10/21/16 C2250 Equity
26-09-2016	SPX US	10-21-16	C	2230	2.146,1	0,97	SPX US 10/21/16 C2230 Equity
27-09-2016	SPX US	10-21-16	C	2245	2.159,9	0,43	SPX US 10/21/16 C2245 Equity
28-09-2016	SPX US	10-21-16	C	2255	2.171,4	0,3	SPX US 10/21/16 C2255 Equity
29-09-2016	SPX US	10-21-16	C	2235	2.151,1	0,5	SPX US 10/21/16 C2235 Equity
30-09-2016	SPX US	10-21-16	C	2255	2.168,3	0,2	SPX US 10/21/16 C2255 Equity
03-10-2016	SPX US	10-21-16	C	2245	2.161,2	0,26	SPX US 10/21/16 C2245 Equity
04-10-2016	SPX US	10-21-16	C	2235	2.150,5	0,3	SPX US 10/21/16 C2235 Equity
05-10-2016	SPX US	10-21-16	C	2245	2.159,7	0,2	SPX US 10/21/16 C2245 Equity
06-10-2016	SPX US	10-21-16	C	2245	2.160,8	0,15	SPX US 10/21/16 C2245 Equity
07-10-2016	SPX US	10-21-16	C	2240	2.153,7	0,15	SPX US 10/21/16 C2240 Equity
10-10-2016	SPX US	10-21-16	C	2250	2.163,7	0,05	SPX US 10/21/16 C2250 Equity
11-10-2016	SPX US	10-21-16	C	2220	2.136,7	0,1	SPX US 10/21/16 C2220 Equity
12-10-2016	SPX US	10-21-16	C	2225	2.139,2	0,1	SPX US 10/21/16 C2225 Equity
13-10-2016	SPX US	10-21-16	C	2220	2.132,6	0,05	SPX US 10/21/16 C2220 Equity
14-10-2016	SPX US	10-21-16	C	2220	2.133,0	0,05	SPX US 10/21/16 C2220 Equity
17-10-2016	SPX US	10-21-16	C	2210	2.126,5	0,02	SPX US 10/21/16 C2210 Equity
18-10-2016	SPX US	10-21-16	C	2225	2.139,6	0,05	SPX US 10/21/16 C2225 Equity
19-10-2016	SPX US	10-21-16	C	2230	2.144,3	0,05	SPX US 10/21/16 C2230 Equity
20-10-2016	SPX US	10-21-16	C	2225	2.141,3	0,05	SPX US 10/21/16 C2225 Equity
21-10-2016	SPX US	10-21-16	C	2225	2.141,2	-	SPX US 10/21/16 C2225 Equity

Testing high volatility expectation trades – 2016 events

SHORT BUTTERFLY SPREAD WITH CALLS - S&P 500

4,00%

K2

Buy date	Asset	Maturity date	Call/Put	Strike Price	Spot Price	Option Price	Ticker
18-05-2016	SPX US	11-18-16	C	2130	2.048,0	-	SPX US 11/18/16 C2130 Equity
18-08-2016	SPX US	11-18-16	C	2270	2.187,0	-	SPX US 11/18/16 C2270 Equity
19-10-2016	SPX US	11-18-16	C	2225	2.144,3	1,53	SPX US 11/18/16 C2225 Equity
24-10-2016	SPX US	11-18-16	C	2235	2.151,3	0,58	SPX US 11/18/16 C2235 Equity
25-10-2016	SPX US	11-18-16	C	2230	2.143,2	0,75	SPX US 11/18/16 C2230 Equity
26-10-2016	SPX US	11-18-16	C	2225	2.139,4	0,7	SPX US 11/18/16 C2225 Equity
27-10-2016	SPX US	11-18-16	C	2220	2.133,0	0,9	SPX US 11/18/16 C2220 Equity
28-10-2016	SPX US	11-18-16	C	2210	2.126,4	1,2	SPX US 11/18/16 C2210 Equity
31-10-2016	SPX US	11-18-16	C	2210	2.126,1	1,4	SPX US 11/18/16 C2210 Equity
01-11-2016	SPX US	11-18-16	C	2195	2.111,7	1,85	SPX US 11/18/16 C2195 Equity
02-11-2016	SPX US	11-18-16	C	2185	2.097,9	1,95	SPX US 11/18/16 C2185 Equity
03-11-2016	SPX US	11-18-16	C	2175	2.088,7	2,9	SPX US 11/18/16 C2175 Equity
04-11-2016	SPX US	11-18-16	C	2170	2.085,2	3,5	SPX US 11/18/16 C2170 Equity
07-11-2016	SPX US	11-18-16	C	2215	2.131,5	0,75	SPX US 11/18/16 C2215 Equity
08-11-2016	SPX US	11-18-16	C	2225	2.139,6	0,7	SPX US 11/18/16 C2225 Equity
09-11-2016	SPX US	11-18-16	C	2250	2.163,3	0,3	SPX US 11/18/16 C2250 Equity
10-11-2016	SPX US	11-18-16	C	2250	2.167,5	0,15	SPX US 11/18/16 C2250 Equity
11-11-2016	SPX US	11-18-16	C	2250	2.164,4	0,2	SPX US 11/18/16 C2250 Equity
14-11-2016	SPX US	11-18-16	C	2210	2.126,5	0,28	SPX US 11/18/16 C2210 Equity
15-11-2016	SPX US	11-18-16	C	2225	2.139,6	0,3	SPX US 11/18/16 C2225 Equity
16-11-2016	SPX US	11-18-16	C	2230	2.144,3	0,23	SPX US 11/18/16 C2230 Equity
17-11-2016	SPX US	11-18-16	C	2225	2.141,3	0,1	SPX US 11/18/16 C2225 Equity
18-11-2016	SPX US	11-18-16	C	2225	2.141,2	-	SPX US 11/18/16 C2225 Equity
16-06-2016	SPX US	12-16-16	C	2165	2.078,0	-	SPX US 12/16/16 C2165 Equity
15-09-2016	SPX US	12-16-16	C	2225	2.147,3	20,2	SPX US 12/16/16 C2225 Equity
18-11-2016	SPX US	12-16-16	C	2265	2.181,9	1,35	SPX US 12/16/16 C2265 Equity
21-11-2016	SPX US	12-16-16	C	2290	2.198,2	0,65	SPX US 12/16/16 C2290 Equity
22-11-2016	SPX US	12-16-16	C	2295	2.202,9	0,7	SPX US 12/16/16 C2295 Equity
23-11-2016	SPX US	12-16-16	C	2295	2.204,7	0,7	SPX US 12/16/16 C2295 Equity
25-11-2016	SPX US	12-16-16	C	2305	2.213,4	0,75	SPX US 12/16/16 C2305 Equity
28-11-2016	SPX US	12-16-16	C	2290	2.201,7	0,75	SPX US 12/16/16 C2290 Equity
29-11-2016	SPX US	12-16-16	C	2295	2.204,7	0,55	SPX US 12/16/16 C2295 Equity
30-11-2016	SPX US	12-16-16	C	2290	2.198,8	0,5	SPX US 12/16/16 C2290 Equity
01-12-2016	SPX US	12-16-16	C	2280	2.191,1	0,55	SPX US 12/16/16 C2280 Equity
02-12-2016	SPX US	12-16-16	C	2280	2.191,9	0,48	SPX US 12/16/16 C2280 Equity
05-12-2016	SPX US	12-16-16	C	2295	2.204,7	0,4	SPX US 12/16/16 C2295 Equity
06-12-2016	SPX US	12-16-16	C	2300	2.212,2	0,15	SPX US 12/16/16 C2300 Equity
07-12-2016	SPX US	12-16-16	C	2330	2.241,4	-	SPX US 12/16/16 C2330 Equity
08-12-2016	SPX US	12-16-16	C	2335	2.246,2	-	SPX US 12/16/16 C2335 Equity
09-12-2016	SPX US	12-16-16	C	2350	2.259,5	0,3	SPX US 12/16/16 C2350 Equity
12-12-2016	SPX US	12-16-16	C	2345	2.257,0	0,25	SPX US 12/16/16 C2345 Equity
13-12-2016	SPX US	12-16-16	C	2360	2.271,7	0,25	SPX US 12/16/16 C2360 Equity
14-12-2016	SPX US	12-16-16	C	2345	2.253,3	0,1	SPX US 12/16/16 C2345 Equity
15-12-2016	SPX US	12-16-16	C	2350	2.262,0	0,05	SPX US 12/16/16 C2350 Equity
16-12-2016	SPX US	12-16-16	C	2350	2.258,1	-	SPX US 12/16/16 C2350 Equity

Testing high volatility expectation trades – 2016 events

Short butterfly spread data for K' (middle strike) – S&P 500 index

SHORT BUTTERFLY SPREAD WITH CALLS - S&P 500

ATM
K'

Buy date	Asset	Maturity date	Call/Put	Strike Price	Spot Price	Option Price	Ticker
21-04-2016	SPX US	10-21-16	C	2090	2.091,0	-	SPX US 10/21/16 C2090 Equity
21-07-2016	SPX US	10-21-16	C	2165	2.165,0	-	SPX US 10/21/16 C2165 Equity
23-09-2016	SPX US	10-21-16	C	2165	2.164,7	24,32	SPX US 10/21/16 C2165 Equity
26-09-2016	SPX US	10-21-16	C	2145	2.146,1	29,2	SPX US 10/21/16 C2145 Equity
27-09-2016	SPX US	10-21-16	C	2160	2.159,9	23,06	SPX US 10/21/16 C2160 Equity
28-09-2016	SPX US	10-21-16	C	2170	2.171,4	22,5	SPX US 10/21/16 C2170 Equity
29-09-2016	SPX US	10-21-16	C	2150	2.151,1	29,08	SPX US 10/21/16 C2150 Equity
30-09-2016	SPX US	10-21-16	C	2170	2.168,3	21,4	SPX US 10/21/16 C2170 Equity
03-10-2016	SPX US	10-21-16	C	2160	2.161,2	21,8	SPX US 10/21/16 C2160 Equity
04-10-2016	SPX US	10-21-16	C	2150	2.150,5	22,2	SPX US 10/21/16 C2150 Equity
05-10-2016	SPX US	10-21-16	C	2160	2.159,7	19,35	SPX US 10/21/16 C2160 Equity
06-10-2016	SPX US	10-21-16	C	2160	2.160,8	20	SPX US 10/21/16 C2160 Equity
07-10-2016	SPX US	10-21-16	C	2155	2.153,7	17	SPX US 10/21/16 C2155 Equity
10-10-2016	SPX US	10-21-16	C	2165	2.163,7	13,4	SPX US 10/21/16 C2165 Equity
11-10-2016	SPX US	10-21-16	C	2135	2.136,7	20,2	SPX US 10/21/16 C2135 Equity
12-10-2016	SPX US	10-21-16	C	2140	2.139,2	16,21	SPX US 10/21/16 C2140 Equity
13-10-2016	SPX US	10-21-16	C	2135	2.132,6	15	SPX US 10/21/16 C2135 Equity
14-10-2016	SPX US	10-21-16	C	2135	2.133,0	12,9	SPX US 10/21/16 C2135 Equity
17-10-2016	SPX US	10-21-16	C	2125	2.133,0	14,5	SPX US 10/21/16 C2125 Equity
18-10-2016	SPX US	10-21-16	C	2140	2.133,0	8	SPX US 10/21/16 C2140 Equity
19-10-2016	SPX US	10-21-16	C	2145	2.133,0	5,84	SPX US 10/21/16 C2145 Equity
20-10-2016	SPX US	10-21-16	C	2140	2.133,0	5,6	SPX US 10/21/16 C2140 Equity
21-10-2016	SPX US	10-21-16	C	2140	2.133,0	-	SPX US 10/21/16 C2140 Equity
18-05-2016	SPX US	11-18-16	C	2050	2.048,0	-	SPX US 11/18/16 C2050 Equity
18-08-2016	SPX US	11-18-16	C	2185	2.187,0	-	SPX US 11/18/16 C2185 Equity
19-10-2016	SPX US	11-18-16	C	2140	2.141,2	31,8	SPX US 11/18/16 C2140 Equity
24-10-2016	SPX US	11-18-16	C	2150	2.151,3	23,52	SPX US 11/18/16 C2150 Equity
25-10-2016	SPX US	11-18-16	C	2145	2.143,2	24	SPX US 11/18/16 C2145 Equity
26-10-2016	SPX US	11-18-16	C	2140	2.139,4	26,7	SPX US 11/18/16 C2140 Equity
27-10-2016	SPX US	11-18-16	C	2135	2.133,0	26	SPX US 11/18/16 C2135 Equity
28-10-2016	SPX US	11-18-16	C	2125	2.126,4	32,4	SPX US 11/18/16 C2125 Equity
31-10-2016	SPX US	11-18-16	C	2125	2.126,1	30,77	SPX US 11/18/16 C2125 Equity
01-11-2016	SPX US	11-18-16	C	2110	2.111,7	32,5	SPX US 11/18/16 C2110 Equity
02-11-2016	SPX US	11-18-16	C	2100	2.097,9	31,1	SPX US 11/18/16 C2100 Equity
03-11-2016	SPX US	11-18-16	C	2090	2.088,7	34,4	SPX US 11/18/16 C2090 Equity
04-11-2016	SPX US	11-18-16	C	2085	2.085,2	37	SPX US 11/18/16 C2085 Equity
07-11-2016	SPX US	11-18-16	C	2130	2.131,5	30,8	SPX US 11/18/16 C2130 Equity
08-11-2016	SPX US	11-18-16	C	2140	2.139,6	25,5	SPX US 11/18/16 C2140 Equity
09-11-2016	SPX US	11-18-16	C	2165	2.163,3	15,94	SPX US 11/18/16 C2165 Equity
10-11-2016	SPX US	11-18-16	C	2165	2.167,5	16,5	SPX US 11/18/16 C2165 Equity
11-11-2016	SPX US	11-18-16	C	2165	2.164,4	12,49	SPX US 11/18/16 C2165 Equity
14-11-2016	SPX US	11-18-16	C	2125	2.126,5	39,5	SPX US 11/18/16 C2125 Equity
15-11-2016	SPX US	11-18-16	C	2140	2.139,6	39	SPX US 11/18/16 C2140 Equity
16-11-2016	SPX US	11-18-16	C	2145	2.144,3	31,49	SPX US 11/18/16 C2145 Equity
17-11-2016	SPX US	11-18-16	C	2140	2.141,3	45,5	SPX US 11/18/16 C2140 Equity
18-11-2016	SPX US	11-18-16	C	2140	2.141,2	-	SPX US 11/18/16 C2140 Equity

Testing high volatility expectation trades – 2016 events

SHORT BUTTERFLY SPREAD WITH CALLS - S&P 500

ATM

K'

Buy date	Asset	Maturity date	Call/Put	Strike Price	Spot Price	Option Price	Ticker
16-06-2016	SPX US	12-16-16	C	2080	2.078,0	-	SPX US 12/16/16 C2080 Equity
15-09-2016	SPX US	12-16-16	C	2140	2.147,3	63,5	SPX US 12/16/16 C2140 Equity
18-11-2016	SPX US	12-16-16	C	2180	2.181,9	26,1	SPX US 12/16/16 C2180 Equity
21-11-2016	SPX US	12-16-16	C	2200	2.198,2	19,7	SPX US 12/16/16 C2200 Equity
22-11-2016	SPX US	12-16-16	C	2205	2.202,9	20,8	SPX US 12/16/16 C2205 Equity
23-11-2016	SPX US	12-16-16	C	2205	2.204,7	20,1	SPX US 12/16/16 C2205 Equity
25-11-2016	SPX US	12-16-16	C	2215	2.213,4	19,16	SPX US 12/16/16 C2215 Equity
28-11-2016	SPX US	12-16-16	C	2200	2.201,7	21,5	SPX US 12/16/16 C2200 Equity
29-11-2016	SPX US	12-16-16	C	2205	2.204,7	20	SPX US 12/16/16 C2205 Equity
30-11-2016	SPX US	12-16-16	C	2200	2.198,8	21	SPX US 12/16/16 C2200 Equity
01-12-2016	SPX US	12-16-16	C	2190	2.191,1	23	SPX US 12/16/16 C2190 Equity
02-12-2016	SPX US	12-16-16	C	2190	2.191,9	21	SPX US 12/16/16 C2190 Equity
05-12-2016	SPX US	12-16-16	C	2205	2.204,7	14	SPX US 12/16/16 C2205 Equity
06-12-2016	SPX US	12-16-16	C	2210	2.212,2	14	SPX US 12/16/16 C2210 Equity
07-12-2016	SPX US	12-16-16	C	2240	2.241,4	13	SPX US 12/16/16 C2240 Equity
08-12-2016	SPX US	12-16-16	C	2245	2.246,2	15,57	SPX US 12/16/16 C2245 Equity
09-12-2016	SPX US	12-16-16	C	2260	2.259,5	11,53	SPX US 12/16/16 C2260 Equity
12-12-2016	SPX US	12-16-16	C	2255	2.257,0	11,5	SPX US 12/16/16 C2255 Equity
13-12-2016	SPX US	12-16-16	C	2270	2.271,7	11,6	SPX US 12/16/16 C2270 Equity
14-12-2016	SPX US	12-16-16	C	2255	2.253,3	8,33	SPX US 12/16/16 C2255 Equity
15-12-2016	SPX US	12-16-16	C	2260	2.262,0	6,5	SPX US 12/16/16 C2260 Equity
16-12-2016	SPX US	12-16-16	C	2260	2.258,1	-	SPX US 12/16/16 C2260 Equity

Strike prices for short butterfly spread – S&P 500

SPX US				
	-4%	4%	K1	K2
2090	-85	85	2005	2175
2165	-85	85	2080	2250
2165	-85	85	2080	2250
2145	-85	85	2060	2230
2160	-85	85	2075	2245
2170	-85	85	2085	2255
2150	-85	85	2065	2235
2170	-85	85	2085	2255
2160	-85	85	2075	2245
2150	-85	85	2065	2235
2160	-85	85	2075	2245
2160	-85	85	2075	2245
2155	-85	85	2070	2240
2165	-85	85	2080	2250
2135	-85	85	2050	2220
2140	-85	85	2055	2225
2135	-85	85	2050	2220
2135	-85	85	2050	2220
2125	-85	85	2040	2210
2140	-85	85	2055	2225

Testing high volatility expectation trades – 2016 events

SPX US				
	-4%	4%	K1	K2
2145	-85	85	2060	2230
2140	-85	85	2055	2225
2140	-85	85	2055	2225
2050	-80	80	1970	2130
2185	-85	85	2100	2270
2140	-85	85	2055	2225
2150	-85	85	2065	2235
2145	-85	85	2060	2230
2140	-85	85	2055	2225
2135	-85	85	2050	2220
2125	-85	85	2040	2210
2125	-85	85	2040	2210
2110	-85	85	2025	2195
2100	-85	85	2015	2185
2090	-85	85	2005	2175
2085	-85	85	2000	2170
2130	-85	85	2045	2215
2140	-85	85	2055	2225
2165	-85	85	2080	2250
2165	-85	85	2080	2250
2165	-85	85	2080	2250
2125	-85	85	2040	2210
2140	-85	85	2055	2225
2145	-85	85	2060	2230
2140	-85	85	2055	2225
2140	-85	85	2055	2225
2080	-85	85	1995	2165
2140	-85	85	2055	2225
2180	-85	85	2095	2265
2200	-90	90	2110	2290
2205	-90	90	2115	2295
2205	-90	90	2115	2295
2215	-90	90	2125	2305
2200	-90	90	2110	2290
2205	-90	90	2115	2295
2200	-90	90	2110	2290
2190	-90	90	2100	2280
2190	-90	90	2100	2280
2205	-90	90	2115	2295
2210	-90	90	2120	2300
2240	-90	90	2150	2330
2245	-90	90	2155	2335
2260	-90	90	2170	2350

Testing high volatility expectation trades – 2016 events

SPX US				
	-4%	4%	K1	K2
2255	-90	90	2165	2345
2270	-90	90	2180	2360
2255	-90	90	2165	2345
2260	-90	90	2170	2350
2260	-90	90	2170	2350

Testing high volatility expectation trades – 2016 events

Closing prices for S&P 500 Index

S&P 500		S&P 500		S&P 500	
Date	Close	Date	Close	Date	Close
21-04-2016	2.091,0	21-10-2016	2.141,2	08-12-2016	2.246,2
18-05-2016	2.048,0	24-10-2016	2.151,3	09-12-2016	2.259,5
16-06-2016	2.078,0	25-10-2016	2.143,2	12-12-2016	2.257,0
19-07-2016	2.163,8	26-10-2016	2.139,4	13-12-2016	2.271,7
21-07-2016	2.165,0	27-10-2016	2.133,0	14-12-2016	2.253,3
18-08-2016	2.187,0	28-10-2016	2.126,4	15-12-2016	2.262,0
16-09-2016	2.139,0	31-10-2016	2.126,1	16-12-2016	2.258,1
15-09-2016	2.147,3	01-11-2016	2.111,7		
16-09-2016	2.139,2	02-11-2016	2.097,9		
19-09-2016	2.139,1	03-11-2016	2.088,7		
20-09-2016	2.139,8	04-11-2016	2.085,2		
21-09-2016	2.163,1	07-11-2016	2.131,5		
22-09-2016	2.177,2	08-11-2016	2.139,6		
23-09-2016	2.164,7	09-11-2016	2.163,3		
26-09-2016	2.146,1	10-11-2016	2.167,5		
27-09-2016	2.159,9	11-11-2016	2.164,4		
28-09-2016	2.171,4	14-11-2016	2.164,2		
29-09-2016	2.151,1	15-11-2016	2.180,4		
30-09-2016	2.168,3	16-11-2016	2.176,9		
03-10-2016	2.161,2	17-11-2016	2.187,1		
04-10-2016	2.150,5	18-11-2016	2.181,9		
05-10-2016	2.159,7	21-11-2016	2.198,2		
06-10-2016	2.160,8	22-11-2016	2.202,9		
07-10-2016	2.153,7	23-11-2016	2.204,7		
10-10-2016	2.163,7	25-11-2016	2.213,4		
11-10-2016	2.136,7	28-11-2016	2.201,7		
12-10-2016	2.139,2	29-11-2016	2.204,7		
13-10-2016	2.132,6	30-11-2016	2.198,8		
14-10-2016	2.133,0	01-12-2016	2.191,1		
17-10-2016	2.126,5	02-12-2016	2.191,9		
18-10-2016	2.139,6	05-12-2016	2.204,7		
19-10-2016	2.144,3	06-12-2016	2.212,2		
20-10-2016	2.141,3	07-12-2016	2.241,4		

Appendix 2⁴

Results presentation – United Kingdom Referendum

LONG STRADDLE 1

Underlying asset: FTSE 100

Expiration date: 17-06-2016

BREXIT: 24th June, 2016														
FTSE 100														
Buy date	Spot price at Buy date	Expiry date	Long Call (ATM)			Long Put (ATM)			Net premium paid	Downside breakeven point	Upside breakeven point	Spot price FTSE at maturity (\$)	Payoff (in EUR)	Price change between spot prices
			Call premium paid (ask)	Long call strike price (K)	Long call payoff	Put premium paid (ask)	Long put strike price (K)	Long put payoff						
17-12-2015	6102,5	06-17-16	382	6100	-382,0	508,6	6100	-429,7	890,6	5209	6991	6021,1	-811,69	-1,3%
17-03-2016	6201,1	06-17-16	230,9	6200	-230,9	338	6200	-159,1	568,9	5631	6769	6021,1	-389,99	-2,9%
20-05-2016	6156,3	06-17-16	137,9	6150	-137,9	159,7	6150	-30,8	297,6	5852	6448	6021,1	-168,69	-2,2%
23-05-2016	6136,4	06-17-16	127,5	6150	-127,5	152,8	6150	-23,9	280,3	5870	6430	6021,1	-151,39	-1,9%
24-05-2016	6219,3	06-17-16	144,8	6200	-144,8	120,7	6200	58,2	265,5	5935	6466	6021,1	-86,59	-3,2%
25-05-2016	6262,9	06-17-16	124,1	6250	-124,1	121,9	6250	107,0	246	6004	6496	6021,1	-17,09	-3,9%
26-05-2016	6265,7	06-17-16	121,6	6250	-121,6	117,2	6250	111,7	238,8	6011	6489	6021,1	-9,89	-3,9%
27-05-2016	6270,8	06-17-16	97,9	6250	-97,9	107,6	6250	121,3	205,5	6045	6456	6021,1	23,41	-4,0%
31-05-2016	6230,8	06-17-16	78,2	6250	-78,2	131,4	6250	97,5	209,6	6040	6460	6021,1	19,31	-3,4%
01-06-2016	6191,9	06-17-16	89,4	6200	-89,4	134,1	6200	44,8	223,5	5977	6424	6021,1	-44,59	-2,8%
02-06-2016	6185,6	06-17-16	90,9	6200	-90,9	112,6	6200	66,3	203,5	5997	6404	6021,1	-24,59	-2,7%
03-06-2016	6209,6	06-17-16	94,4	6200	-94,4	101,6	6200	77,3	196	6004	6396	6021,1	-17,09	-3,0%
06-06-2016	6273,4	06-17-16	96,6	6250	-96,6	72,3	6250	156,6	168,9	6081	6419	6021,1	60,01	-4,0%
07-06-2016	6284,5	06-17-16	57,5	6300	-57,5	104	6300	174,9	161,5	6139	6462	6021,1	117,41	-4,2%
08-06-2016	6301,5	06-17-16	65,4	6300	-65,4	76,3	6300	202,6	141,7	6158	6442	6021,1	137,21	-4,5%
09-06-2016	6231,9	06-17-16	52,4	6250	-52,4	89,7	6250	139,2	142,1	6108	6392	6021,1	86,81	-3,4%
10-06-2016	6115,8	06-17-16	114	6100	-114,0	85,3	6100	-6,4	199,3	5901	6299	6021,1	-120,39	-1,5%
13-06-2016	6045,0	06-17-16	94,6	6050	-94,6	81,1	6050	-52,2	175,7	5874	6226	6021,1	-146,79	-0,4%
14-06-2016	5923,5	06-17-16	104,7	5900	16,4	73,6	5900	-73,6	178,3	5722	6078	6021,1	-57,21	1,6%
15-06-2016	5966,8	06-17-16	87,8	5950	-16,7	45,3	5950	-45,3	133,1	5817	6083	6021,1	-62,01	0,9%
16-06-2016	5950,5	06-17-16	43,2	5950	27,9	24,1	5950	-24,1	67,3	5883	6017	6021,1	3,79	1,2%
17-06-2016	6021,1	06-17-16	63,7	6000	-42,6	0	6000	0,0	63,7	5936	6064	6021,1	-	0,0%

⁴ All the data regarding the option prices and index prices, was exported from *Bloomberg*

LONG STRADDLE 2

Underlying asset: FTSE 100

Expiration date: 15-07-2016

FTSE 100																
Buy date	Spot price at Buy date	Expiry date	Long Call (ATM)				Long Put (ATM)				Net premium paid	Downside breakeven point	Upside breakeven point	Spot price FTSE at maturity (St)	Payoff (in EUR)	Price change between spot prices
			Call premium paid (ask)	Long call strike price (K)	Payoff Long call	Put premium paid (ask)	Long put strike price (K)	Payoff Long put								
18-01-2016	5779,9	07-15-16	392,2	5800	477,0	574,8	5800	-574,8	967	4833	6767	6669,2	-97,76	15,4%		
18-04-2016	6353,5	07-15-16	287	6350	32,2	349,1	6350	-349,1	636,1	5714	6986	6669,2	-316,86	5,0%		
17-06-2016	6021,1	07-15-16	284,1	6000	385,1	277	6000	-277,0	561,1	5439	6561	6669,2	108,14	10,8%		
20-06-2016	6204,0	07-15-16	256,9	6200	212,3	242,9	6200	-242,9	499,8	5700	6700	6669,2	-30,56	7,5%		
21-06-2016	6226,6	07-15-16	251,5	6250	167,7	253,7	6250	-253,7	505,2	5745	6755	6669,2	-85,96	7,1%		
22-06-2016	6261,2	07-15-16	315,4	6250	103,8	239,7	6250	-239,7	555,1	5695	6805	6669,2	-135,86	6,5%		
23-06-2016	6338,1	07-15-16	222,9	6350	96,3	261,4	6350	-261,4	484,3	5866	6834	6669,2	-165,06	5,2%		
24-06-2016	6138,7	07-15-16	205	6150	314,2	192,6	6150	-192,6	397,6	5752	6548	6669,2	121,64	8,6%		
27-06-2016	5982,2	07-15-16	187,6	6000	481,6	216,7	6000	-216,7	404,3	5596	6404	6669,2	264,94	11,5%		
28-06-2016	6140,4	07-15-16	150,6	6150	368,6	185,3	6150	-185,3	335,9	5814	6486	6669,2	183,34	8,6%		
29-06-2016	6360,1	07-15-16	148,9	6350	170,3	165,7	6350	-165,7	314,6	6035	6665	6669,2	4,64	4,9%		
30-06-2016	6504,3	07-15-16	112,1	6500	57,1	142	6500	-142,0	254,1	6246	6754	6669,2	-84,86	2,5%		
01-07-2016	6577,8	07-15-16	99	6600	-29,8	124,9	6600	-124,9	223,9	6376	6824	6669,2	-154,66	1,4%		
04-07-2016	6522,3	07-15-16	130,3	6500	38,9	95,1	6500	-95,1	225,4	6275	6725	6669,2	-56,16	2,3%		
05-07-2016	6545,4	07-15-16	107	6550	12,2	95,9	6550	-95,9	202,9	6347	6753	6669,2	-83,66	1,9%		
06-07-2016	6463,6	07-15-16	126,2	6450	93,0	99,7	6450	-99,7	225,9	6224	6676	6669,2	-6,66	3,2%		
07-07-2016	6533,8	07-15-16	89,7	6550	29,5	90,3	6550	-90,3	180	6370	6730	6669,2	-60,76	2,1%		
08-07-2016	6590,6	07-15-16	69,4	6600	-0,2	66,1	6600	-66,1	135,5	6465	6736	6669,2	-66,26	1,2%		
11-07-2016	6682,9	07-15-16	54,5	6700	-54,5	73,9	6700	-43,1	128,4	6572	6828	6669,2	-97,64	-0,2%		
12-07-2016	6680,7	07-15-16	49,1	6700	-49,1	74,4	6700	-43,6	123,5	6577	6824	6669,2	-92,74	-0,2%		
13-07-2016	6670,4	07-15-16	95,6	6650	-76,4	31,7	6650	-31,7	127,3	6523	6777	6669,2	-108,06	-0,02%		
14-07-2016	6654,5	07-15-16	48	6650	-28,8	30	6650	-30,0	78	6572	6728	6669,2	-58,76	0,2%		
15-07-2016	6669,2	07-15-16	0	6650	19,2	19,1	6650	-19,1	19,1	6631	6669	6669,2	-	0,0%		

LONG STRADDLE 3

Underlying asset: DAX 30

Expiration date: 17-06-2016

DAX Index															
Buy date	Spot price at Buy date	Long Call (ATM)				Long Put (ATM)				Net premium paid	Downside breakeven point	Upside breakeven point	Spot price DAX at maturity (St)	Payoff (in EUR)	Price change between spot prices
		Call premium paid (ask)	Long call strike price (K)	Payoff long call	Put premium paid (ask)	Long put strike price (K)	Payoff long put								
17-12-2015	10738	741,1	10750	-741,1	691,23	10750	427,4	1432,33	9317,67	12182,33	9631,4	-313,69	-10,3%		
17-03-2016	9892	490,97	9900	-491,0	482,71	9900	-214,1	973,68	8926,32	10873,68	9631,4	-705,04	-2,6%		
20-05-2016	9916	253,53	9900	-253,5	242,87	9900	25,8	496,4	9403,6	10396,4	9631,4	-227,76	-2,9%		
23-05-2016	9842	240,9	9850	-240,9	231,93	9850	-13,3	472,83	9377,17	10322,83	9631,4	-254,19	-2,1%		
24-05-2016	10057	225,43	10050	-225,4	201,46	10050	217,2	426,89	9623,11	10476,89	9631,4	-8,25	-4,2%		
25-05-2016	10205	203,21	10200	-203,2	195,39	10200	373,2	398,6	9801,4	10598,6	9631,4	170,04	-5,6%		
26-05-2016	10273	207,65	10250	-207,7	177,47	10250	441,2	385,12	9864,88	10635,12	9631,4	233,52	-6,2%		
27-05-2016	10286	159,26	10300	-159,3	190,44	10300	478,2	349,7	9950,3	10649,7	9631,4	318,94	-6,4%		
30-05-2016	10333	158,88	10350	-158,9	173,91	10350	544,7	332,79	10017,21	10682,79	9631,4	385,85	-6,8%		
31-05-2016	10263	176,33	10250	-176,3	161,29	10250	457,3	337,62	9912,38	10587,62	9631,4	281,02	-6,2%		
01-06-2016	10204	168,62	10200	-168,6	174,2	10200	394,4	342,82	9857,18	10542,82	9631,4	225,82	-5,6%		
02-06-2016	10208	167,34	10200	-167,3	145,03	10200	423,6	312,37	9887,63	10512,37	9631,4	256,27	-5,6%		
03-06-2016	10103	145,43	10100	-145,4	156,19	10100	312,4	301,62	9798,38	10401,62	9631,4	167,02	-4,7%		
06-06-2016	10121	154,97	10100	-155,0	117,99	10100	350,6	272,96	9827,04	10372,96	9631,4	195,68	-4,8%		
07-06-2016	10288	112,13	10300	-112,1	125,18	10300	543,5	237,31	10062,69	10537,31	9631,4	431,33	-6,4%		
08-06-2016	10217	114,79	10200	-114,8	109,09	10200	459,5	223,88	9976,12	10423,88	9631,4	344,76	-5,7%		
09-06-2016	10089	99,72	10100	-99,7	114,44	10100	354,2	214,16	9885,84	10314,16	9631,4	254,48	-4,5%		
10-06-2016	9835	124,51	9850	-124,5	140,3	9850	78,3	264,81	9585,19	10114,81	9631,4	-46,17	-2,1%		
13-06-2016	9657	150,98	9650	-151,0	112,61	9650	-94,0	263,59	9386,41	9913,59	9631,4	-244,95	-0,3%		
14-06-2016	9519	138,14	9500	-6,8	124,13	9500	-124,1	262,27	9237,73	9762,27	9631,4	-130,91	1,2%		
15-06-2016	9607	108	9600	-76,6	79,34	9600	-79,3	187,34	9412,66	9787,34	9631,4	-155,98	0,3%		
16-06-2016	9550	62,42	9550	18,9	41,13	9550	-41,1	103,55	9446,45	9653,55	9631,4	-22,19	0,8%		
17-06-2016	9631	0	9650	0,0	20,37	9650	-1,7	0	9650	9650	9631,4	-	0,0%		

LONG STRADDLE 4

Underlying asset: DAX 30

Expiration date: 15-07-2016

DAX Index														
Buy date	Spot price at Buy date	Long Call (ATM)				Long Put (ATM)				Net premium paid	Upside breakeven point	Spot price DAX at maturity (St)	Payoff (in EUR)	Price change between spot prices
		Call premium paid (ask)	Long call strike price (K)	Payoff long call	Put premium paid (ask)	Long put strike price (K)	Payoff long put	Downside breakeven point						
18-01-2016	9522	0	9500	-	0	9500	-	0	980,63	11080,63	10066,9	-	-	-0,5%
18-04-2016	10120	524,91	10100	-524,9	455,72	10100	-422,6	9119,37	980,63	11080,63	10066,9	-	-947,53	4,5%
17-06-2016	9631	385,33	9650	31,6	430,96	9650	-431,0	8833,71	816,29	10466,29	10066,9	-	-399,39	1,1%
20-06-2016	9962	368,42	9950	-251,5	358,46	9950	-358,5	9223,12	726,88	10676,88	10066,9	-	-609,98	0,5%
21-06-2016	10016	385,4	10000	-318,5	344,08	10000	-344,1	9270,52	729,48	10729,48	10066,9	-	-662,58	-0,04%
22-06-2016	10071	448,16	10050	-431,3	351,75	10050	-351,8	9250,09	799,91	10849,91	10066,9	-	-783,01	-1,9%
23-06-2016	10257	330,26	10250	-330,3	340,48	10250	-157,4	9579,26	670,74	10920,74	10066,9	-	-487,64	5,3%
24-06-2016	9557	333,31	9550	183,6	320,02	9550	-320,0	8896,67	653,33	10203,33	10066,9	-	-136,43	8,6%
27-06-2016	9269	303,54	9250	513,4	288,97	9250	-289,0	8657,49	592,51	9842,51	10066,9	-	224,39	6,6%
28-06-2016	9447	241,18	9450	375,7	269,14	9450	-269,1	8939,68	510,32	9960,32	10066,9	-	106,58	4,7%
29-06-2016	9612	236,05	9600	230,9	238,61	9600	-238,6	9125,34	474,66	10074,66	10066,9	-	-7,76	4,0%
30-06-2016	9680	190,12	9700	176,8	213,6	9700	-213,6	9296,28	403,72	10103,72	10066,9	-	-36,82	3,0%
01-07-2016	9776	163,71	9800	103,2	200,69	9800	-200,7	9435,6	364,4	10164,4	10066,9	-	-97,50	3,7%
04-07-2016	9709	180,04	9700	186,9	164,77	9700	-164,8	9355,19	344,81	10044,81	10066,9	-	22,09	5,6%
05-07-2016	9533	162,58	9550	354,3	187,75	9550	-187,8	9199,67	350,33	9900,33	10066,9	-	166,57	7,4%
06-07-2016	9373	189,07	9350	527,8	171,1	9350	-171,1	8989,83	360,17	9710,17	10066,9	-	356,73	6,9%
07-07-2016	9419	164,85	9400	502,1	142,06	9400	-142,1	9093,09	306,91	9706,91	10066,9	-	359,99	4,5%
08-07-2016	9630	114,64	9650	302,3	129,9	9650	-129,9	9405,46	244,54	9894,54	10066,9	-	172,36	2,4%
11-07-2016	9833	92,85	9850	124,1	113,4	9850	-113,4	9643,75	206,25	10056,25	10066,9	-	10,65	1,0%
12-07-2016	9964	97,39	9950	19,5	71,99	9950	-72,0	9780,62	169,38	10119,38	10066,9	-	-52,48	1,4%
13-07-2016	9931	69,99	9950	46,9	69,43	9950	-69,4	9810,58	139,42	10089,42	10066,9	-	-22,52	-0,01%
14-07-2016	10068	54,68	10050	-37,8	32,67	10050	-32,7	9962,65	87,35	10137,35	10066,9	-	-70,45	0,0%
15-07-2016	10067	0	10050	16,9	69,33	10050	-69,3	10050	0	10050	10066,9	-	-	

LONG STRADDLE – Results Summary

Long straddle 1 FTSE (06-17-16)	Nr of trades	Value of trades
Positive results	7	448
Negative results	14	- 2.108
TOTAL (Added value)	21	- 1.660

Long straddle 2 FTSE (07-15-16)	Nr of trades	Value of trades
Positive results	5	683
Negative results	17	- 1.702
TOTAL (Added value)	22	- 1.020

Long straddle 3 DAX (06-17-16)	Nr of trades	Value of trades
Positive results	12	3.265
Negative results	10	- 2.109
TOTAL (Added value)	22	1.156

Long straddle 4 DAX (07-15-16)	Nr of trades	Value of trades
Positive results	8	1.419
Negative results	13	- 4.314
TOTAL (Added value)	21	- 2.895

LONG STRADDLE	Nr of trades	Value of trades
Positive results	32	5.815
Negative results	54	- 10.234
TOTAL (Added value)	86	- 4.419

LONG STRANGLE 1

Underlying asset: FTSE 100

Expiration date: 17-06-2016

BREXIT: 24th June, 2016														
FTSE 100														
Buy date	Spot price at Buy date	Expiry date	Long Put (ITM)			Long Call (OTM)			Net premium paid	Downside breakeven point	Upside breakeven point	Spot price FTSE at maturity (St)	Payoff (in EUR)	Price change between spot prices
			Put premium paid (ask)	Long put strike price (ITM)	Payoff Long Put	Call premium paid (ask)	Long call strike price K2 (OTM)	Payoff Long Call						
17-12-2015	6102,5	06-17-16	336,6	5800	-336,6	563	6400	-563,0	899,6	4900,4	7299,6	6021,1	-899,60	-1,3%
17-03-2016	6201,1	06-17-16	186,7	5900	-186,7	602,1	6500	-602,1	788,8	5111,2	7288,8	6021,1	-788,80	-2,9%
20-05-2016	6156,3	06-17-16	45	5850	-45,0	8,7	6450	-8,7	53,7	5796,3	6503,7	6021,1	-53,70	-2,2%
23-05-2016	6136,4	06-17-16	37,7	5850	-37,7	8,7	6450	-8,7	46,4	5803,6	6496,4	6021,1	-46,40	-1,9%
24-05-2016	6219,3	06-17-16	27,1	5900	-27,1	10,2	6500	-10,2	37,3	5862,7	6537,3	6021,1	-37,30	-3,2%
25-05-2016	6262,9	06-17-16	25	5950	-25,0	7,3	6550	-7,3	32,3	5917,7	6582,3	6021,1	-32,30	-3,9%
26-05-2016	6265,7	06-17-16	22,7	5950	-22,7	5,1	6550	-5,1	27,8	5922,2	6577,8	6021,1	-27,80	-3,9%
27-05-2016	6270,8	06-17-16	17,6	5950	-17,6	3,7	6550	-3,7	21,3	5928,7	6571,3	6021,1	-21,30	-4,0%
31-05-2016	6230,8	06-17-16	21,8	5950	-21,8	2,2	6550	-2,2	24	5926	6574	6021,1	-24,00	-3,4%
01-06-2016	6191,9	06-17-16	22,4	5900	-22,4	2,2	6500	-2,2	24,6	5875,4	6524,6	6021,1	-24,60	-2,8%
02-06-2016	6185,6	06-17-16	18	5900	-18,0	1,4	6500	-1,4	19,4	5880,6	6519,4	6021,1	-19,40	-2,7%
03-06-2016	6209,6	06-17-16	16,7	5900	-16,7	1,5	6500	-1,5	18,2	5881,8	6518,2	6021,1	-18,20	-3,0%
06-06-2016	6273,4	06-17-16	8,7	5950	-8,7	1,4	6550	-1,4	10,1	5939,9	6560,1	6021,1	-10,10	-4,0%
07-06-2016	6284,5	06-17-16	10,9	6000	-10,9	0,7	6600	-0,7	11,6	5988,4	6611,6	6021,1	-11,60	-4,2%
08-06-2016	6301,5	06-17-16	6,5	6000	-6,5	0,7	6600	-0,7	7,2	5992,8	6607,2	6021,1	-7,20	-4,5%
09-06-2016	6231,9	06-17-16	9,4	5950	-9,4	0,7	6550	-0,7	10,1	5939,9	6560,1	6021,1	-10,10	-3,4%
10-06-2016	6115,8	06-17-16	12,2	5800	-12,2	1,4	6400	-1,4	13,6	5786,4	6413,6	6021,1	-13,60	-1,5%
13-06-2016	6045,0	06-17-16	8,5	5750	-8,5	0,7	6350	-0,7	9,2	5740,8	6359,2	6021,1	-9,20	-0,4%
14-06-2016	5923,5	06-17-16	5,7	5600	-5,7	1,4	6200	-1,4	7,1	5592,9	6207,1	6021,1	-7,10	1,6%
15-06-2016	5966,8	06-17-16	1,4	5650	-1,4	0	6250	0,0	1,4	5648,6	6251,4	6021,1	-	-
16-06-2016	5950,5	06-17-16	0	5650	0,0	0	6250	0,0	0	5650	6250	6021,1	-	-
17-06-2016	6021,1	06-17-16	0	5700	0,0	0	6300	0,0	0	5700	6300	6021,1	-	-

LONG STRANGLE 2

Underlying asset: FTSE 100

Expiration date: 15-07-2016

FTSE 100																
Buy date	Spot price at Buy date	Expiry date	Long Put (ITM)				Long Call (OTM)				Net premium paid	Downside breakeven point	Upside breakeven point	Spot price FTSE at maturity (\$t)	Payoff (in EUR)	Price change between spot prices
			Put premium paid (ask)	Long put strike price K1 (ITM)	Payoff Long Put	Call premium paid (ask)	Long call strike price K2 (OTM)	Payoff Long Call								
18-01-2016	5779,9	07-15-16	399,3	5500	-399,3	204,7	6100	364,5	604	4896	6704	6669,2	-34,76	15,4%		
18-04-2016	6353,5	07-15-16	208,4	6050	-208,4	92,8	6650	-73,6	301,2	5748,8	6951,2	6669,2	-281,96	5,0%		
17-06-2016	6021,1	07-15-16	143,1	5700	-143,1	87,3	6300	281,9	230,4	5469,6	6530,4	6669,2	138,84	10,8%		
20-06-2016	6204,0	07-15-16	118,2	5900	-118,2	53,6	6500	115,6	171,8	5728,2	6671,8	6669,2	-2,56	7,5%		
21-06-2016	6226,6	07-15-16	132	5950	-132,0	47,7	6550	71,5	179,7	5770,3	6729,7	6669,2	-60,46	7,1%		
22-06-2016	6261,2	07-15-16	131,6	5950	-131,6	76,5	6550	42,7	208,1	5741,9	6758,1	6669,2	-88,86	6,5%		
23-06-2016	6338,1	07-15-16	137	6050	-137,0	18,5	6650	0,7	155,5	5894,5	6805,5	6669,2	-136,26	5,2%		
24-06-2016	6138,7	07-15-16	86,7	5850	-86,7	31	6450	188,2	117,7	5732,3	6567,7	6669,2	101,54	8,6%		
27-06-2016	5982,2	07-15-16	91,8	5700	-91,8	33,7	6300	335,5	125,5	5574,5	6425,5	6669,2	243,74	11,5%		
28-06-2016	6140,4	07-15-16	64	5850	-64,0	16,7	6450	202,5	80,7	5769,3	6530,7	6669,2	138,54	8,6%		
29-06-2016	6360,1	07-15-16	54,6	6050	-54,6	12,8	6650	6,4	67,4	5982,6	6717,4	6669,2	-48,16	4,9%		
30-06-2016	6504,3	07-15-16	34,5	6150	-34,5	1,3	6850	-1,3	35,8	6114,2	6885,8	6669,2	-35,80	2,5%		
01-07-2016	6577,8	07-15-16	26,6	6250	-26,6	1,3	6950	-1,3	27,9	6222,1	6977,9	6669,2	-27,90	1,4%		
04-07-2016	6522,3	07-15-16	19,3	6150	-19,3	1,3	6850	-1,3	20,6	6129,4	6870,6	6669,2	-20,60	2,3%		
05-07-2016	6545,4	07-15-16	17,6	6200	-17,6	0,7	6900	-0,7	18,3	6181,7	6918,3	6669,2	-18,30	1,9%		
06-07-2016	6463,6	07-15-16	22,7	6150	-22,7	4,5	6750	-4,5	27,2	6122,8	6777,2	6669,2	-27,20	3,2%		
07-07-2016	6533,8	07-15-16	11	6200	-11,0	0	6900	0,0	11	6189	6911	6669,2	-	2,1%		
08-07-2016	6590,6	07-15-16	3,9	6250	-3,9	0	6950	0,0	3,9	6246,1	6953,9	6669,2	-	1,2%		
11-07-2016	6682,9	07-15-16	2,6	6350	-2,6	0	7050	0,0	2,6	6347,4	7052,6	6669,2	-	-0,2%		
12-07-2016	6680,7	07-15-16	2	6350	-2,0	0,7	7050	-0,7	2,7	6347,3	7052,7	6669,2	-2,70	-0,2%		
13-07-2016	6670,4	07-15-16	1,3	6300	-1,3	0,7	7000	-0,7	2	6298	7002	6669,2	-2,00	0,0%		
14-07-2016	6654,5	07-15-16	0,7	6300	-0,7	0	7000	0,0	0,7	6299,3	7000,7	6669,2	-	0,2%		
15-07-2016	6669,2	07-15-16	0	6300	0,0	0	7000	0,0	0	6300	7000	6669,2	-	0,0%		

LONG STRANGLE 3

Underlying asset: DAX 30

Expiration date: 17-06-2016

DAX Index														
Buy date	Spot price at Buy date	Expiry date	Long Put (ITM)			Long Call (OTM)			Net premium paid	Downside breakeven in point	Upside breakeven point	Spot price DAX at maturity (St)	Payoff (in EUR)	Price change between spot prices
			Put premium paid (ask)	Long put strike price K1 (ITM)	Payoff Long Put	Call premium paid (ask)	Long call strike price K2 (OTM)	Payoff Long Call						
17-12-2015	10738	06-17-16	465	10200	103,6	453,42	11300	-453,4	918,42	9282	12218	9.631,4	-349,78	-10,3%
17-03-2016	9892	06-17-16	288,72	9400	-288,7	225,12	10400	-225,1	513,84	8886	10914	9.631,4	-513,84	-2,6%
20-05-2016	9916	06-17-16	82,86	9400	-82,9	45,75	10400	-45,8	128,61	9271	10529	9.631,4	-128,61	-2,9%
23-05-2016	9842	06-17-16	74,21	9350	-74,2	39,91	10350	-39,9	114,12	9236	10464	9.631,4	-114,12	-2,1%
24-05-2016	10057	06-17-16	57,42	9550	-57,4	30,99	10550	-31,0	88,41	9462	10638	9.631,4	-88,41	-4,2%
25-05-2016	10205	06-17-16	53,56	9700	15,1	23,55	10700	-23,6	77,11	9623	10777	9.631,4	-8,47	-5,6%
26-05-2016	10273	06-17-16	45,26	9750	73,4	25,15	10750	-25,2	70,41	9680	10820	9.631,4	48,23	-6,2%
27-05-2016	10286	06-17-16	43,43	9800	125,2	15,26	10800	-15,3	58,69	9741	10859	9.631,4	109,95	-6,4%
30-05-2016	10333	06-17-16	35,52	9850	183,1	14,03	10850	-14,0	49,55	9800	10900	9.631,4	169,09	-6,8%
31-05-2016	10263	06-17-16	34,53	9750	84,1	15,82	10750	-15,8	50,35	9700	10800	9.631,4	68,29	-6,2%
01-06-2016	10204	06-17-16	40,9	9700	27,7	13,07	10700	-13,1	53,97	9646	10754	9.631,4	14,67	-5,6%
02-06-2016	10208	06-17-16	29,9	9700	38,7	10,49	10700	-10,5	40,39	9660	10740	9.631,4	28,25	-5,6%
03-06-2016	10103	06-17-16	28,99	9600	-29,0	7,25	10600	-7,3	36,24	9564	10636	9.631,4	-36,24	-4,7%
06-06-2016	10121	06-17-16	16,95	9600	-17,0	6,03	10600	-6,0	22,98	9577	10623	9.631,4	-22,98	-4,8%
07-06-2016	10288	06-17-16	12,82	9800	155,8	3,75	10800	-3,8	16,57	9783	10817	9.631,4	152,07	-6,4%
08-06-2016	10217	06-17-16	9,69	9700	58,9	3,42	10700	-3,4	13,11	9687	10713	9.631,4	55,53	-5,7%
09-06-2016	10089	06-17-16	9,62	9600	-9,6	2,83	10600	-2,8	12,45	9588	10612	9.631,4	-12,45	-4,5%
10-06-2016	9835	06-17-16	16,92	9350	-16,9	3,5	10350	-3,5	20,42	9330	10370	9.631,4	-20,42	-2,1%
13-06-2016	9657	06-17-16	10,95	9150	-11,0	4,4	10150	-4,4	15,35	9135	10165	9.631,4	-15,35	-0,3%
14-06-2016	9519	06-17-16	11,66	9000	-11,7	4,82	10000	-4,8	16,48	8984	10016	9.631,4	-16,48	1,2%
15-06-2016	9607	06-17-16	2,81	9100	-2,8	1,01	10100	-1,0	3,82	9096	10104	9.631,4	-3,82	0,3%
16-06-2016	9550	06-17-16	0,34	9050	-0,3	0,11	10050	-0,1	0,45	9050	10050	9.631,4	-0,45	0,8%
17-06-2016	9631	06-17-16	0,01	9150	0,0	0,01	10150	0,0	0,02	9150	10150	9.631,4	-	0,0%

LONG STRANGLE 4

Underlying asset: DAX 30

Expiration date: 15-07-2016

DAX Index														
Buy date	Spot price at Buy date	Expiry date	Long Put (ITM)			Long Call (OTM)			Net premium paid	Downside breakeven point	Upside breakeven point	Spot price DAX at maturity (St)	Payoff (in EUR)	Price change between spot prices
			Put premium paid (ask)	Long put strike price K1 (ITM)	Payoff Long Put	Call premium paid (ask)	Long call strike price K2 (OTM)	Payoff Long Call						
18-01-2016	9522	07-15-16	0	9000	-	0	10000	-	867,5	-	10.066,9	-	5,7%	
18-04-2016	10120	07-15-16	272,82	9600	-272,8	594,68	10600	-594,7	8732,5	11467,5	10.066,9	-867,50	-0,5%	
17-06-2016	9631	07-15-16	229,96	9150	-230,0	133,96	10150	-134,0	363,92	10513,92	10.066,9	-363,92	4,5%	
20-06-2016	9962	07-15-16	181,61	9450	-181,6	104,21	10450	-104,2	285,82	10735,82	10.066,9	-285,82	1,1%	
21-06-2016	10016	07-15-16	184,31	9500	-184,3	104,15	10500	-104,2	288,46	10788,46	10.066,9	-288,46	0,5%	
22-06-2016	10071	07-15-16	196,22	9550	-196,2	138,91	10550	-138,9	335,13	10885,13	10.066,9	-335,13	0,0%	
23-06-2016	10257	07-15-16	177,79	9750	-177,8	66,64	10750	-66,6	244,43	10994,43	10.066,9	-244,43	-1,9%	
24-06-2016	9557	07-15-16	146,5	9050	-146,5	90,56	10050	-73,7	237,06	10287,06	10.066,9	-220,16	5,3%	
27-06-2016	9269	07-15-16	123,29	8800	-123,3	97,58	9700	269,3	220,87	9920,87	10.066,9	146,03	8,6%	
28-06-2016	9447	07-15-16	103,35	9000	-103,4	55,71	9900	111,2	159,06	10059,06	10.066,9	7,84	6,6%	
29-06-2016	9612	07-15-16	75,91	9100	-75,9	39,4	10100	-39,4	115,31	10215,31	10.066,9	-115,31	4,7%	
30-06-2016	9680	07-15-16	57,25	9200	-57,3	18,16	10200	-18,2	75,41	10275,41	10.066,9	-75,41	4,0%	
01-07-2016	9776	07-15-16	48,56	9300	-48,6	12,47	10300	-12,5	61,03	10361,03	10.066,9	-61,03	3,0%	
04-07-2016	9709	07-15-16	36,45	9200	-36,5	10,26	10200	-10,3	46,71	10246,71	10.066,9	-46,71	3,7%	
05-07-2016	9533	07-15-16	43,92	9050	-43,9	8,21	10050	8,7	52,13	10102,13	10.066,9	-35,23	5,6%	
06-07-2016	9373	07-15-16	42,47	8900	-42,5	19,85	9800	247,1	62,32	9862,32	10.066,9	204,58	7,4%	
07-07-2016	9419	07-15-16	26	8950	-26,0	11,95	9850	205,0	37,95	9887,95	10.066,9	178,95	6,9%	
08-07-2016	9630	07-15-16	12,93	9150	-12,9	1,88	10150	-1,9	14,81	10164,81	10.066,9	-14,81	4,5%	
11-07-2016	9833	07-15-16	10,61	9350	-10,6	1,66	10350	-1,7	12,27	10362,27	10.066,9	-12,27	2,4%	
12-07-2016	9964	07-15-16	5,99	9450	-6,0	2,33	10450	-2,3	8,32	10458,32	10.066,9	-8,32	1,0%	
13-07-2016	9931	07-15-16	4,11	9450	-4,1	2,22	10450	-2,2	6,33	10456,33	10.066,9	-6,33	1,4%	
14-07-2016	10068	07-15-16	0,78	9550	-0,8	0,89	10550	-0,9	1,67	10551,67	10.066,9	-1,67	0,0%	
15-07-2016	10067	07-15-16	0,01	9550	0,0	0,01	10550	0,0	0,02	10550,02	10.066,9	-	0,0%	

LONG STRANGLE – Results Summary

Long strangle 1 FTSE (06-17-16)	Nr of trades	Value of trades
Positive results	0	-
Negative results	19	- 2.062
TOTAL (Added value)	19	- 2.062

Long strangle 2 FTSE (07-15-16)	Nr of trades	Value of trades
Positive results	4	623
Negative results	14	- 788
TOTAL (Added value)	18	- 165

Long strangle 3 DAX (06-17-16)	Nr of trades	Value of trades
Positive results	8	646
Negative results	14	- 1.331
TOTAL (Added value)	22	- 685

Long strangle 4 DAX (07-15-16)	Nr of trades	Value of trades
Positive results	4	537
Negative results	17	- 2.983
TOTAL (Added value)	21	- 2.445

LONG STRANGLE	Nr of trades	Value of trades
Positive results	16	1.806
Negative results	64	- 7.164
TOTAL (Added value)	80	- 5.358

SHORT BUTTERFLY SPREAD WITH CALLS 1

Underlying asset: FTSE 100

Expiration date: 17-06-2016

BREXIT: 24th June, 2016																	
FTSE 100																	
Buy date	Spot price at Buy date	Expiry date	Short Call (ITM)				Short call (OTM)				2 Long Call (ATM)						
			Call premium received (bid)	Short Call strike price K1 (ITM)	Payoff Short Call (ITM)	Call premium received (bid)	Short Call strike price K2 (OTM)	Payoff Short Call (OTM)	Call premium paid (ask)	Long Call strike price K' (ATM)	Payoff Long Call (ATM)	Net premium received	Downside breakeven point	Upside breakeven point	Spot price FTSE at maturity	Payoff	Price change between spot prices
17-12-2015	6102,5	06-17-16	707,4	5750	436,3	159,4	6450	159,4	382	6100	-764,0	-102,8	5852,8	6347,2	6.021,1	-168,3	-1,3%
17-03-2016	6201,1	06-17-16	567,4	5850	396,3	44,9	6550	44,9	230,9	6200	-461,8	-150,5	6000,5	6399,5	6.021,1	-20,6	-2,9%
20-05-2016	6156,3	06-17-16	522,5	5800	301,4	4,4	6500	4,4	137,9	6150	-275,8	-251,1	6051,1	6248,9	6.021,1	30,0	-2,2%
23-05-2016	6136,4	06-17-16	511,3	5800	290,2	5,1	6500	5,1	127,5	6150	-255,0	-261,4	6061,4	6238,6	6.021,1	40,3	-1,9%
24-05-2016	6219,3	06-17-16	556,5	5850	385,4	6,6	6550	6,6	144,8	6200	-289,6	-273,5	6123,5	6276,5	6.021,1	102,4	-3,2%
25-05-2016	6262,9	06-17-16	605,1	5850	434,0	2,9	6650	2,9	124,1	6250	-248,2	-359,8	6209,8	6290,2	6.021,1	188,7	-3,9%
26-05-2016	6265,7	06-17-16	604,5	5850	433,4	1,5	6650	1,5	121,6	6250	-243,2	-362,8	6212,8	6287,2	6.021,1	191,7	-3,9%
27-05-2016	6270,8	06-17-16	597,2	5850	426,1	0,7	6650	0,7	109	6250	-218,0	-379,9	6229,9	6270,1	6.021,1	208,8	-4,0%
31-05-2016	6230,8	06-17-16	547,9	5850	376,8	0,7	6650	0,7	87,1	6250	-174,2	-374,4	6224,4	6275,6	6.021,1	203,3	-3,4%
01-06-2016	6191,9	06-17-16	476,6	5850	305,5	1,4	6550	1,4	89,4	6200	-178,8	-299,2	6149,2	6250,8	6.021,1	128,1	-2,8%
02-06-2016	6185,6	06-17-16	496,6	5850	325,5	0,7	6550	0,7	90,9	6200	-181,8	-315,5	6165,5	6234,5	6.021,1	144,4	-2,7%
03-06-2016	6209,6	06-17-16	513,2	5850	342,1	0,7	6550	0,7	94,4	6200	-188,8	-325,1	6175,1	6224,9	6.021,1	154,0	-3,0%
06-06-2016	6273,4	06-17-16	620,4	5850	449,3	0	6650	0	109,9	6250	-219,8	-400,6	6250,6	6249,4	6.021,1	-	-4,0%
07-06-2016	6284,5	06-17-16	541,2	5900	420,1	0	6700	0	57,5	6300	-115,0	-426,2	6326,2	6273,8	6.021,1	-	-4,2%
08-06-2016	6301,5	06-17-16	574,1	5900	453,0	0	6700	0	65,4	6300	-130,8	-443,3	6343,3	6256,7	6.021,1	-	-4,5%
09-06-2016	6231,9	06-17-16	552,5	5850	381,4	0	6650	0	59,3	6250	-118,6	-433,9	6283,9	6216,1	6.021,1	-	-3,4%
10-06-2016	6115,8	06-17-16	539,1	5750	268,0	0,7	6450	0,7	114	6100	-228,0	-311,8	6061,8	6138,2	6.021,1	40,7	-1,5%
13-06-2016	6045,0	06-17-16	517,3	5700	196,2	0	6400	0	94,6	6050	-189,2	-328,1	6028,1	6071,9	6.021,1	-	-0,4%
14-06-2016	5923,5	06-17-16	529,8	5550	58,7	0,7	6250	0,7	104,7	5900	32,8	-321,1	5871,1	5928,9	6.021,1	92,2	1,6%
15-06-2016	5966,8	06-17-16	539,1	5600	118,0	0	6300	0	87,8	5950	-33,4	-363,5	5963,5	5936,5	6.021,1	-	0,9%
16-06-2016	5950,5	06-17-16	515,3	5600	94,2	0	6300	0	43,2	5950	55,8	-428,9	6028,9	5871,1	6.021,1	-	1,2%
17-06-2016	6021,1	06-17-16	564,7	5650	193,6	0	6350	0	63,7	6000	-85,2	-437,3	6087,3	5912,7	6.021,1	-	0,0%

SHORT BUTTERFLY SPREAD WITH CALLS 2

Underlying asset: FTSE 100

Expiration date: 15-07-2016

Buy date	Spot price at Buy date	Expiry date	Short Call (ITM)			Short call (OTM)			2 Long Call (ATM)			Upside breakeven point	Downside breakeven point	Net premium received	Spot price FTSE at maturity	Payoff	Price change between spot prices
			Call premium received (bid)	Short Call strike price K1 (ITM)	Short Call Payoff (ITM)	Call premium received (bid)	Short Call strike price K2 (OTM)	Short Call Payoff (OTM)	Call premium paid (ask)	Long Call strike price K' (ATM)	Long Call Payoff (ATM)						
18-01-2016	5779,9	07-15-16	0	5450	-	180,4	6150	-	392,2	5800	-	-	-	-	-	-	-
18-04-2016	6353,5	07-15-16	683,9	5950	-	0	6750	-	287	6350	-	-	-	-	-	-	-
17-06-2016	6021,1	07-15-16	636,3	5650	-382,9	67,3	6350	-251,94	284,1	6000	770,28	-135,4	5785,4	6214,6	6669,24	135,4	10,76%
20-06-2016	6204,0	07-15-16	631,2	5850	-188,04	35,2	6550	-84,04	256,9	6200	424,68	-152,6	6002,6	6397,4	6669,24	152,6	7,50%
21-06-2016	6226,6	07-15-16	690,6	5850	-128,64	19,1	6650	-0,14	251,5	6250	335,48	-206,7	6056,7	6443,3	6669,24	206,7	7,11%
22-06-2016	6261,2	07-15-16	770,5	5850	-48,74	33,1	6650	13,86	315,4	6250	207,68	-172,8	6022,8	6477,2	6669,24	172,8	6,52%
23-06-2016	6338,1	07-15-16	662,7	5950	-56,54	4,4	6750	4,4	222,9	6350	192,68	-221,3	6171,3	6528,7	6669,24	140,5	5,22%
24-06-2016	6138,7	07-15-16	569,6	5800	-299,64	19,3	6500	-149,94	205	6150	628,48	-178,9	5978,9	6321,1	6669,24	178,9	8,64%
27-06-2016	5982,2	07-15-16	511,4	5650	-507,84	21,8	6350	-297,44	187,6	6000	963,28	-158	5808	6192	6669,24	158,0	11,48%
28-06-2016	6140,4	07-15-16	484,5	5800	-384,74	9,3	6500	-159,94	150,6	6150	737,28	-192,6	5992,6	6307,4	6669,24	192,6	8,61%
29-06-2016	6360,1	07-15-16	559,1	5950	-160,14	3,4	6750	3,4	148,9	6350	340,68	-264,7	6214,7	6485,3	6669,24	183,9	4,86%
30-06-2016	6504,3	07-15-16	529,4	6100	-39,84	0,7	6900	0,7	112,1	6500	114,28	-305,9	6405,9	6594,1	6669,24	75,1	2,54%
01-07-2016	6577,8	07-15-16	526,6	6200	57,36	0,7	7000	0,7	99	6600	-59,52	-329,3	6529,3	6670,7	6669,24	-1,5	1,39%
04-07-2016	6522,3	07-15-16	582,3	6100	13,06	0,7	6900	0,7	130,3	6500	77,88	-322,4	6422,4	6577,6	6669,24	91,6	2,25%
05-07-2016	6545,4	07-15-16	546,9	6150	27,66	0	6950	0	107	6550	24,48	-332,9	6482,9	6617,1	6669,24	-	1,89%
06-07-2016	6463,6	07-15-16	557,9	6050	-61,34	0,6	6850	0,6	126,2	6450	186,08	-306,1	6356,1	6543,9	6669,24	125,3	3,18%
07-07-2016	6533,8	07-15-16	523,9	6150	4,66	0	6950	0	89,7	6550	59,08	-344,5	6494,5	6605,5	6669,24	-	2,07%
08-07-2016	6590,6	07-15-16	524,4	6200	55,16	0	7000	0	69,4	6600	-0,32	-385,6	6585,6	6614,4	6669,24	-	1,19%
11-07-2016	6682,9	07-15-16	501,2	6300	131,96	0,2	7100	0,2	54,5	6700	-109	-392,4	6692,4	6707,6	6669,24	-	-0,20%
12-07-2016	6680,7	07-15-16	507,3	6300	138,06	0,7	7100	0,7	49,1	6700	-98,2	-409,8	6709,8	6690,2	6669,24	40,6	-0,17%
13-07-2016	6670,4	07-15-16	592,3	6250	173,06	0,7	7050	0,7	95,6	6650	-152,72	-401,8	6651,8	6648,2	6669,24	21,0	-0,02%
14-07-2016	6654,5	07-15-16	550,8	6250	131,56	0	7050	0	48	6650	-57,52	-454,8	6704,8	6595,2	6669,24	-	0,22%
15-07-2016	6669,2	07-15-16	508,1	6250	88,86	0	7050	0	0	6650	38,48	-508,1	6758,1	6541,9	6669,24	-	0,00%

SHORT BUTTERFLY SPREAD WITH CALLS 3

Underlying asset: DAX 30

Expiration date: 17-06-2016

DAX Index																
Buy date	Spot price at Buy date	Short Call (ITM)				Short call (OTM)				2 Long Call (ATM)				Price change between spot prices		
		Call premium received (bid)	Short Call strike price K1 (ITM)	Payoff Short Call (ITM)	Call premium received (bid)	Short Call strike price K2 (OTM)	Payoff Short Call (OTM)	Call premium paid (ask)	Long Call strike price K' (ATM)	Payoff Long Call (ATM)	Net premium received	Downside breakeven point	Upside breakeven point		Spot price S&P at maturity	Payoff
17-12-2015	10738	1185,44	10100	1.185,4	410,26	11400	410,3	741,1	10750	-1482,2	-113,5	10213,5	11286,5	9.631,4	113,5	-10,3%
17-03-2016	9892	948	9300	616,6	186,2	10500	186,2	490,97	9900	-981,9	-152,24	9452,24	10347,76	9.631,4	-179,1	-2,6%
20-05-2016	9916	749,7	9300	418,3	28,37	10500	28,4	253,53	9900	-507,1	-271,01	9571,01	10228,99	9.631,4	-60,4	-2,9%
23-05-2016	9842	739,97	9250	358,6	24,55	10450	24,6	240,9	9850	-481,8	-282,72	9532,72	10167,28	9.631,4	-98,6	-2,1%
24-05-2016	10057	737,28	9450	555,9	18,4	10650	18,4	225,43	10050	-450,9	-304,82	9754,82	10345,18	9.631,4	123,5	-4,2%
25-05-2016	10205	718,75	9600	687,4	13,84	10800	13,8	203,21	10200	-406,4	-326,17	9926,17	10473,83	9.631,4	294,8	-5,6%
26-05-2016	10273	735,72	9650	735,7	15,2	10850	15,2	207,65	10250	-415,3	-335,62	9985,62	10514,38	9.631,4	335,6	-6,2%
27-05-2016	10286	669,78	9700	669,8	9,13	10900	9,1	159,26	10300	-318,5	-360,39	10060,39	10539,61	9.631,4	360,4	-6,4%
30-05-2016	10333	679,17	9750	679,2	8,35	10950	8,4	158,88	10350	-317,8	-369,76	10119,76	10580,24	9.631,4	369,8	-6,8%
31-05-2016	10263	709,55	9650	709,6	8,91	10850	8,9	176,33	10250	-352,7	-365,8	10015,8	10484,2	9.631,4	365,8	-6,2%
01-06-2016	10204	696,25	9600	664,9	7,15	10800	7,2	168,62	10200	-337,2	-366,16	9966,16	10433,84	9.631,4	334,8	-5,6%
02-06-2016	10208	714,43	9600	683,1	5,47	10800	5,5	167,34	10200	-334,7	-385,22	9985,22	10414,78	9.631,4	353,9	-5,6%
03-06-2016	10103	690,43	9500	559,1	4,19	10700	4,2	145,43	10100	-290,9	-403,76	9903,76	10296,24	9.631,4	272,4	-4,7%
06-06-2016	10121	731,83	9500	600,5	3,07	10700	3,1	154,97	10100	-309,9	-424,96	9924,96	10275,04	9.631,4	293,6	-4,8%
07-06-2016	10288	676,63	9700	676,6	2,04	10900	2,0	112,13	10300	-224,3	-454,41	10154,41	10445,59	9.631,4	454,4	-6,4%
08-06-2016	10217	696,25	9600	664,9	2,05	10800	2,1	114,79	10200	-229,6	-468,72	10068,72	10331,28	9.631,4	437,4	-5,7%
09-06-2016	10089	670,76	9500	539,4	1,7	10700	1,7	99,72	10100	-199,4	-473,02	9973,02	10226,98	9.631,4	341,7	-4,5%
10-06-2016	9835	671,83	9250	290,5	1,69	10450	1,7	124,51	9850	-249,0	-424,5	9674,5	10025,5	9.631,4	43,1	-2,1%
13-06-2016	9657	722,29	9050	140,9	2,14	10250	2,1	150,98	9650	-302,0	-422,47	9472,47	9827,53	9.631,4	-158,9	-0,3%
14-06-2016	9519	639,93	8950	-41,4	3,25	10050	3,3	138,14	9500	-13,6	-366,9	9316,9	9683,1	9.631,4	-51,7	1,2%
15-06-2016	9607	704,62	9000	73,3	0,45	10200	0,5	108	9600	-153,3	-489,07	9489,07	9710,93	9.631,4	-79,6	0,3%
16-06-2016	9550	637,9	9000	6,5	0,11	10100	0,1	62,42	9550	37,9	-513,17	9513,17	9586,83	9.631,4	44,5	0,8%
17-06-2016	9631	655,65	9050	74,3	0,01	10250	0,0	0,01	9650	0,0	-655,64	9705,64	9594,36	9.631,4	-	0,0%

SHORT BUTTERFLY SPREAD WITH CALLS 4

Underlying asset: DAX 30

Expiration date: 15-07-2016

DAX Index																
Buy date	Spot price at buy date	Expiry date	Short Call (ITM)			Short call (OTM)			2 Long Call (ATM)			Upside breakeven point	Downside breakeven point	Spot price S&P at maturity	Payoff	Price change between spot prices
			Call premium received (bid)	Short Call strike price K1 (ITM)	Short Call payoff (ITM)	Call premium received (bid)	Short Call strike price K2 (OTM)	Short Call payoff (OTM)	Call premium paid (ask)	Long Call strike price K' (ATM)	Long Call payoff (ATM)					
18-01-2016	9522	07-15-16	0	8950	-	0	10050	-	0	9500	-	-	-	10,066,9	-	-
18-04-2016	10120	07-15-16	995,13	9500	428,2	200,11	10700	200,1	524,91	10100	-1049,82	-145,42	9645,42	10554,58	10,066,9	-421,5
17-06-2016	9631	07-15-16	831,73	9050	-185,1704	100,84	10250	100,84	385,33	9650	63,140782	-161,91	9211,91	10088,09	10,066,9	-21,2
20-06-2016	9962	07-15-16	846,25	9350	129,34961	72,19	10550	72,19	368,42	9950	-503,0392	-181,6	9531,6	10368,4	10,066,9	-301,5
21-06-2016	10016	07-15-16	878,88	9400	211,97961	70,48	10600	70,48	385,4	10000	-636,9992	-178,56	9578,56	10421,44	10,066,9	-354,5
22-06-2016	10071	07-15-16	948,77	9450	331,86961	98,45	10650	98,45	448,16	10050	-862,5192	-150,9	9600,9	10499,1	10,066,9	-432,2
23-06-2016	10257	07-15-16	826,04	9650	409,13961	41,55	10850	41,55	330,26	10250	-660,52	-207,07	9857,07	10642,93	10,066,9	-209,8
24-06-2016	9557	07-15-16	762,08	9000	-304,8204	75,93	10100	75,93	333,31	9550	367,18078	-171,39	9171,39	9928,61	10,066,9	138,3
27-06-2016	9269	07-15-16	721,11	8700	-645,7904	70,64	9800	-196,2604	303,54	9250	1026,7208	-184,67	8884,67	9615,33	10,066,9	184,7
28-06-2016	9447	07-15-16	661,52	8900	-505,3804	35,7	10000	-31,20039	241,18	9450	751,44078	-214,86	9114,86	9785,14	10,066,9	214,9
29-06-2016	9612	07-15-16	628,26	9100	-338,6404	24,3	10200	24,3	206,53	9650	420,74078	-239,5	9339,5	9960,5	10,066,9	106,4
30-06-2016	9680	07-15-16	684,2	9100	-282,7004	10,08	10300	10,08	190,12	9700	353,56078	-314,04	9414,04	9985,96	10,066,9	80,9
01-07-2016	9776	07-15-16	667,44	9200	-199,4604	6,57	10400	6,57	163,71	9800	206,38078	-346,59	9546,59	10053,41	10,066,9	122,9
04-07-2016	9709	07-15-16	711,02	9100	-255,8804	5,02	10300	5,02	180,04	9800	373,72078	-355,96	9455,96	9944,04	10,066,9	122,9
05-07-2016	9533	07-15-16	622,15	9000	-444,7504	5,43	10100	5,43	162,58	9550	708,64078	-302,42	9302,42	9797,58	10,066,9	269,3
06-07-2016	9373	07-15-16	657,69	8800	-609,2104	9,31	9900	-157,5904	189,07	9350	1055,6608	-288,86	9088,86	9611,14	10,066,9	288,9
07-07-2016	9419	07-15-16	648,35	8850	-568,5504	5,2	9950	-111,7004	164,85	9400	1004,1008	-323,85	9173,85	9626,15	10,066,9	323,9
08-07-2016	9630	07-15-16	656	9050	-360,9004	0,55	10250	0,55	114,64	9650	604,52078	-427,27	9477,27	9822,73	10,066,9	244,2
11-07-2016	9833	07-15-16	649,47	9250	-167,4304	0,77	10450	0,77	92,85	9850	248,10078	-464,54	9714,54	9985,46	10,066,9	81,4
12-07-2016	9964	07-15-16	695,02	9350	-21,88039	1,44	10550	1,44	97,39	9950	39,020782	-501,68	9851,68	10048,32	10,066,9	18,6
13-07-2016	9931	07-15-16	669,76	9350	-47,14039	1,56	10550	1,56	69,99	9950	93,820782	-531,34	9881,34	10018,66	10,066,9	48,2
14-07-2016	10068	07-15-16	689,34	9450	72,439609	0,67	10650	0,67	54,68	10050	-75,55922	-580,65	10030,65	10069,35	10,066,9	-2,4
15-07-2016	10067	07-15-16	594,39	9450	-22,51039	0,01	10650	0,01	0,01	10050	33,780782	-594,38	10044,38	10055,62	10,066,9	-

SHORT BUTTERFLY SPREAD WITH CALLS – Results Summary

SHORT BUT. S. W/ CALLS 1 FTSE (06-17-16)	Nr of trades	Value of trades
Positive results	12	1.525
Negative results	2	- 189
TOTAL (Added value)	14	1.336

SHORT BUT. S. W/ CALLS 2 FTSE (07-15-16)	Nr of trades	Value of trades
Positive results	14	1.875
Negative results	1	- 2
TOTAL (Added value)	15	1.874

SHORT BUT. S. W/ CALLS 3 DAX (06-17-16)	Nr of trades	Value of trades
Positive results	16	4.539
Negative results	6	- 628
TOTAL (Added value)	22	3.911

SHORT BUT. S. W/ CALLS 3 DAX (07-15-16)	Nr of trades	Value of trades
Positive results	15	2.136
Negative results	6	- 1.743
TOTAL (Added value)	21	393

SHORT BUTTERFLY SPREAD W/ CALLS	Nr of trades	Value of trades
Positive results	57	10.075
Negative results	15	- 2.562
TOTAL (Added value)	72	7.513

Results presentation – United States election

LONG STRADDLE 1

Underlying asset: S&P 500

Expiration date: 21-10-2016

USA Elections: 9th November, 2016																
S&P500																
Buy date	Spot price at Buy date	Expiry date	Long Call (ATM)				Long Put (ATM)				Net premium paid	Downside breakeven n point	Upside breakeven point	Spot price S&P at maturity (St)	Payoff (in USD)	Percentage difference between spot prices
			Call premium paid (ask)	Long call strike price (K)	Payoff Long call	Put premium paid (ask)	Long put strike price (K)	Payoff Long put								
21-04-2016	2091,0	10-21-16	0	2090	-	0	2090	-	0,0	2090,0	2090,0	2090,0	2.141,2	-	2,4%	
21-07-2016	2163,8	10-21-16	0	2165	-	0	2165	-	0,0	2165,0	2165,0	2165,0	2.141,2	-	-1,0%	
23-09-2016	2164,7	10-21-16	24,32	2165	-24,3	25	2165	-1,2	49,3	2115,7	2214,3	2214,3	2.141,2	-25,48	-1,1%	
26-09-2016	2146,1	10-21-16	29,1	2145	-29,1	27,75	2145	-23,9	56,9	2088,2	2201,9	2201,9	2.141,2	-53,01	-0,2%	
27-09-2016	2159,9	10-21-16	23,06	2160	-23,1	24,85	2160	-6,0	47,9	2112,1	2207,9	2207,9	2.141,2	-29,07	-0,9%	
28-09-2016	2171,4	10-21-16	22,5	2170	-22,5	23	2170	5,8	45,5	2124,5	2215,5	2215,5	2.141,2	-16,66	-1,4%	
29-09-2016	2151,1	10-21-16	29,08	2150	-29,1	23,32	2150	-14,5	52,4	2097,6	2202,4	2202,4	2.141,2	-43,56	-0,5%	
30-09-2016	2168,3	10-21-16	21,4	2170	-21,4	24	2170	4,8	45,4	2124,6	2215,4	2215,4	2.141,2	-16,56	-1,3%	
03-10-2016	2161,2	10-21-16	21,8	2160	-21,8	22,8	2160	-4,0	44,6	2115,4	2204,6	2204,6	2.141,2	-25,76	-0,9%	
04-10-2016	2150,5	10-21-16	22,2	2150	-22,2	23	2150	-14,2	45,2	2104,8	2195,2	2195,2	2.141,2	-36,36	-0,4%	
05-10-2016	2159,7	10-21-16	19,35	2160	-19,4	20,6	2160	-1,8	40,0	2120,1	2200,0	2200,0	2.141,2	-21,11	-0,9%	
06-10-2016	2160,8	10-21-16	20	2160	-20,0	17,4	2160	1,4	37,4	2122,6	2197,4	2197,4	2.141,2	-18,56	-0,9%	
07-10-2016	2153,7	10-21-16	17	2155	-17,0	19,37	2155	-5,5	36,4	2118,6	2191,4	2191,4	2.141,2	-22,53	-0,6%	
10-10-2016	2163,7	10-21-16	13,4	2165	-13,4	15,35	2165	8,5	28,8	2136,3	2193,8	2193,8	2.141,2	-4,91	-1,0%	
11-10-2016	2136,7	10-21-16	20,2	2135	-14,0	16	2135	-16,0	36,2	2098,8	2171,2	2171,2	2.141,2	-30,04	0,2%	
12-10-2016	2139,2	10-21-16	16,21	2140	-15,1	17,25	2140	-17,3	33,5	2106,5	2173,5	2173,5	2.141,2	-32,30	0,1%	
13-10-2016	2132,6	10-21-16	15	2135	-8,8	18,35	2135	-18,4	33,4	2101,7	2168,4	2168,4	2.141,2	-27,19	0,4%	
14-10-2016	2133,0	10-21-16	12,9	2135	-6,7	15	2135	-15,0	27,9	2107,1	2162,9	2162,9	2.141,2	-21,74	0,4%	
17-10-2016	2126,5	10-21-16	14,5	2125	1,7	9,63	2125	-9,6	24,1	2100,9	2149,1	2149,1	2.141,2	-7,97	0,7%	
18-10-2016	2139,6	10-21-16	8	2140	-6,8	9,5	2140	-9,5	17,5	2122,5	2157,5	2157,5	2.141,2	-16,34	0,1%	
19-10-2016	2144,3	10-21-16	5,84	2145	-5,8	6,75	2145	-2,9	12,6	2132,4	2157,6	2157,6	2.141,2	-8,75	-0,1%	
20-10-2016	2141,3	10-21-16	5,6	2140	-4,4	2,48	2140	-2,5	8,1	2131,9	2148,1	2148,1	2.141,2	-6,92	0,0%	
21-10-2016	2141,2	10-21-16	0	2140	1,2	0	2140	0,0	0,0	2140,0	2140,0	2140,0	2.141,2	-	0,0%	

LONG STRADDLE 2

Underlying asset: S&P 500

Expiration date: 18-11-2016

S&P500														
			Long Call (ATM)				Long Put (ATM)							
Buy date	Spot price at Buy date	Expiry date	Call premium paid (ask)	Long call strike price (K)	Long call payoff	Put premium paid (ask)	Long put strike price (K)	Long put payoff	Net premium paid	Downside breakeven in point	Upside breakeven point	Spot price S&P at maturity (5t)	Payoff (in USD)	Percentage difference between spot prices
18-05-2016	2048,0	11-18-16	0	2050	-	0	2050	-	0,0	2050,0	2050,0	2.181,9	-	
18-08-2016	2187,0	11-18-16	0	2185	-	0	2185	-	0,0	2185,0	2185,0	2.181,9	-	
21-10-2016	2144,3	11-18-16	26,6	2140	15,3	29,1	2140	-29,1	55,7	2084,3	2195,7	2.181,9	-13,80	1,8%
24-10-2016	2151,3	11-18-16	23,52	2150	8,4	26,9	2150	-26,9	50,4	2099,6	2200,4	2.181,9	-18,52	1,4%
25-10-2016	2143,2	11-18-16	24	2145	12,9	28,5	2145	-28,5	52,5	2092,5	2197,5	2.181,9	-15,60	1,8%
26-10-2016	2139,4	11-18-16	26,7	2140	15,2	29	2140	-29,0	55,7	2084,3	2195,7	2.181,9	-13,80	2,0%
27-10-2016	2133,0	11-18-16	26	2135	20,9	33,2	2135	-33,2	59,2	2075,8	2194,2	2.181,9	-12,30	2,3%
28-10-2016	2126,4	11-18-16	32,4	2125	24,5	31	2125	-31,0	63,4	2061,6	2188,4	2.181,9	-6,50	2,6%
31-10-2016	2126,1	11-18-16	30,77	2125	26,1	31	2125	-31,0	61,8	2063,2	2186,8	2.181,9	-4,87	2,6%
01-11-2016	2111,7	11-18-16	32,5	2110	39,4	33,23	2110	-33,2	65,7	2044,3	2175,7	2.181,9	6,17	3,3%
02-11-2016	2097,9	11-18-16	31,1	2100	50,8	36,75	2100	-36,8	67,9	2032,2	2167,9	2.181,9	14,05	4,0%
03-11-2016	2088,7	11-18-16	34,4	2090	57,5	38	2090	-38,0	72,4	2017,6	2162,4	2.181,9	19,50	4,5%
04-11-2016	2085,2	11-18-16	37	2085	59,9	3,65	2085	-3,7	40,7	2044,4	2125,7	2.181,9	56,25	4,6%
07-11-2016	2131,5	11-18-16	30,8	2130	21,1	29,22	2130	-29,2	60,0	2070,0	2190,0	2.181,9	-8,12	2,4%
08-11-2016	2139,6	11-18-16	25,5	2140	16,4	29,5	2140	-29,5	55,0	2085,0	2195,0	2.181,9	-13,10	2,0%
09-11-2016	2163,3	11-18-16	15,94	2165	1,0	17,73	2165	-17,7	33,7	2131,3	2198,7	2.181,9	-16,77	0,9%
10-11-2016	2167,5	11-18-16	16,5	2165	0,4	15	2165	-15,0	31,5	2133,5	2196,5	2.181,9	-14,60	0,7%
11-11-2016	2164,4	11-18-16	12,49	2165	4,4	13,98	2165	-14,0	26,5	2138,5	2191,5	2.181,9	-9,57	0,8%
14-11-2016	2164,2	11-18-16	9	2165	7,9	12,3	2165	-12,3	21,3	2143,7	2186,3	2.181,9	-4,40	0,8%
15-11-2016	2180,4	11-18-16	8,6	2180	-6,7	7,5	2180	-7,5	16,1	2163,9	2196,1	2.181,9	-14,20	0,1%
16-11-2016	2176,9	11-18-16	5,7	2175	1,2	5,36	2175	-5,4	11,1	2163,9	2186,1	2.181,9	-4,16	0,2%
17-11-2016	2187,1	11-18-16	4,5	2185	-4,5	3,42	2185	-0,3	7,9	2177,1	2192,9	2.181,9	-4,82	-0,2%
18-11-2016	2181,9	11-18-16	0	2180	1,9	0	2180	0,0	0,0	2180,0	2180,0	2.181,9	-	0,0%

LONG STRADDLE 3

Underlying asset: S&P 500

Expiration date: 16-12-2016

S&P500																
Buy date	Spot price at Buy date	Expiry date	Long Call (ATM)				Long Put (ATM)				Net premium paid	Downside breakeven in point	Upside breakeven point	Spot price S&P at maturity (St)	Payoff	Percentage difference between spot prices
			Call premium paid (ask)	Long call strike price (K)	Long call payoff	Put premium paid (ask)	Long put strike price (K)	Long put payoff								
16-06-2016	2078,0	12-16-16	0	2080	-	0	2080,0	0,0	2080,0	2080,0	2080,0	2.258,1	-	-	-	
16-09-2016	2147,3	12-16-16	58	2140	60,1	66,5	2140	-66,5	2015,5	2264,5	2264,5	2.258,1	-6,43	-6,43	5,2%	
18-11-2016	2181,9	12-16-16	26,1	2180	52,0	26	2180	-26,0	2127,9	2232,1	2232,1	2.258,1	25,97	25,97	3,5%	
21-11-2016	2198,2	12-16-16	19,7	2200	38,4	26	2200	-26,0	2154,3	2245,7	2245,7	2.258,1	12,37	12,37	2,7%	
22-11-2016	2202,9	12-16-16	20,8	2205	32,3	24,5	2205	-24,5	2159,7	2250,3	2250,3	2.258,1	7,77	7,77	2,5%	
23-11-2016	2204,7	12-16-16	20,1	2205	33,0	24	2205	-24,0	2160,9	2249,1	2249,1	2.258,1	8,97	8,97	2,4%	
25-11-2016	2213,4	12-16-16	19,16	2215	23,9	23,1	2215	-23,1	2172,7	2257,3	2257,3	2.258,1	0,81	0,81	2,0%	
28-11-2016	2201,7	12-16-16	21,5	2200	36,6	21	2200	-21,0	2157,5	2242,5	2242,5	2.258,1	15,57	15,57	2,6%	
29-11-2016	2204,7	12-16-16	20	2205	33,1	22	2205	-22,0	2163,0	2247,0	2247,0	2.258,1	11,07	11,07	2,4%	
30-11-2016	2198,8	12-16-16	21	2200	37,1	21	2200	-21,0	2158,0	2242,0	2242,0	2.258,1	16,07	16,07	2,7%	
01-12-2016	2191,1	12-16-16	23	2190	45,1	21	2190	-21,0	2146,0	2234,0	2234,0	2.258,1	24,07	24,07	3,1%	
02-12-2016	2191,9	12-16-16	21	2190	47,1	21	2190	-21,0	2148,0	2232,0	2232,0	2.258,1	26,07	26,07	3,0%	
05-12-2016	2204,7	12-16-16	14	2205	39,1	16	2205	-16,0	2175,0	2235,0	2235,0	2.258,1	23,07	23,07	2,4%	
06-12-2016	2212,2	12-16-16	14	2210	34,1	13	2210	-13,0	2183,0	2237,0	2237,0	2.258,1	21,07	21,07	2,1%	
07-12-2016	2241,4	12-16-16	13	2240	5,1	14	2240	-14,0	2213,0	2267,0	2267,0	2.258,1	-8,93	-8,93	0,7%	
08-12-2016	2246,2	12-16-16	15,57	2245	-2,5	12,85	2245	-12,9	2216,6	2273,4	2273,4	2.258,1	-15,35	-15,35	0,5%	
09-12-2016	2259,5	12-16-16	11,53	2260	-11,5	11,3	2260	-9,4	2237,2	2282,8	2282,8	2.258,1	-20,90	-20,90	-0,1%	
12-12-2016	2257,0	12-16-16	11,5	2255	-8,4	9,3	2255	-9,3	2234,2	2275,8	2275,8	2.258,1	-17,73	-17,73	0,0%	
13-12-2016	2271,7	12-16-16	11,6	2270	-11,6	8	2270	3,9	2250,4	2289,6	2289,6	2.258,1	-7,67	-7,67	-0,6%	
14-12-2016	2253,3	12-16-16	8,33	2255	-5,3	6,7	2255	-6,7	2240,0	2270,0	2270,0	2.258,1	-11,96	-11,96	0,2%	
15-12-2016	2262,0	12-16-16	6,5	2260	-6,5	3	2260	-1,1	2250,5	2269,5	2269,5	2.258,1	-7,57	-7,57	-0,2%	
16-12-2016	2258,1	12-16-16	0	2260	0,0	0	2260	1,9	2260,0	2260,0	2260,0	2.258,1	-	-	-	

LONG STRADDLE – Results Summary

LONG STRADDLE 1 SPX (10-21-16)	Nr of trades	Value of trades
Positive results	0	-
Negative results	20	- 465
TOTAL (Added value)	20	- 465

LONG STRADDLE 2 SPX (11-18-16)	Nr of trades	Value of trades
Positive results	4	96
Negative results	16	- 175
TOTAL (Added value)	20	- 79

LONG STRADDLE 3 SPX (16-12-16)	Nr of trades	Value of trades
Positive results	12	193
Negative results	8	- 97
TOTAL (Added value)	20	96

LONG STRADDLE	Nr of trades	Value of trades
Positive results	16	289
Negative results	44	- 736
TOTAL (Added value)	60	- 448

LONG STRANGLE 1

Underlying asset: S&P 500

Expiration date: 21-10-2016

USA Elections: 9th November, 2016														
S&P500														
Buy date	Spot price at Buy date	Expiry date	Long Put (ITM)			Long Call (OTM)			Net premium paid	Downside breakeven point	Upside breakeven point	Spot price S&P at maturity	Payoff (in USD)	Percentage difference between spot prices
			Put premium paid (ask)	Long put strike price K1 (ITM)	Payoff Long call	Call premium paid (ask)	Long call strike price K2 (OTM)	Payoff Long put						
21-04-2016	2091,0	10-21-16	0	2025	0,0	0	2155	0,0	0	2025	2155	2.141,2	-	-
21-07-2016	2165,0	10-21-16	38,1	2100	-38,1	18,1	2230	-18,1	56,2	2043,8	2286,2	2.141,2	-56,20	-1,1%
23-09-2016	2164,7	10-21-16	9,5	2100	-9,5	1,35	2230	-1,4	10,85	2089,15	2240,85	2.141,2	-10,85	-1,1%
26-09-2016	2146,1	10-21-16	12	2080	-12,0	2,7	2210	-2,7	14,7	2065,3	2224,7	2.141,2	-14,70	-0,2%
27-09-2016	2159,9	10-21-16	8,98	2095	-9,0	1,2	2225	-1,2	10,18	2084,82	2235,18	2.141,2	-10,18	-0,9%
28-09-2016	2171,4	10-21-16	7,65	2105	-7,7	0,81	2235	-0,8	8,46	2096,54	2243,46	2.141,2	-8,46	-1,4%
29-09-2016	2151,1	10-21-16	10,3	2085	-10,3	2,1	2215	-2,1	12,4	2072,6	2227,4	2.141,2	-12,40	-0,5%
30-09-2016	2168,3	10-21-16	8,75	2105	-8,8	0,7	2235	-0,7	9,45	2095,55	2244,45	2.141,2	-9,45	-1,3%
03-10-2016	2161,2	10-21-16	7,84	2095	-7,8	0,7	2225	-0,7	8,54	2086,46	2233,54	2.141,2	-8,54	-0,9%
04-10-2016	2150,5	10-21-16	6,95	2085	-7,0	0,79	2215	-0,8	7,74	2077,26	2222,74	2.141,2	-7,74	-0,4%
05-10-2016	2159,7	10-21-16	5,37	2095	-5,4	0,52	2225	-0,5	5,89	2089,11	2230,89	2.141,2	-5,89	-0,9%
06-10-2016	2160,8	10-21-16	4,03	2095	-4,0	0,3	2225	-0,3	4,33	2090,67	2229,33	2.141,2	-4,33	-0,9%
07-10-2016	2153,7	10-21-16	4,21	2090	-4,2	0,25	2220	-0,3	4,46	2085,54	2224,46	2.141,2	-4,46	-0,6%
10-10-2016	2163,7	10-21-16	2,49	2100	-2,5	0,13	2230	-0,1	2,62	2097,38	2232,62	2.141,2	-2,62	-1,0%
11-10-2016	2136,7	10-21-16	3,06	2070	-3,1	0,4	2200	-0,4	3,46	2066,54	2203,46	2.141,2	-3,46	0,2%
12-10-2016	2139,2	10-21-16	2,7	2075	-2,7	0,28	2205	-0,3	2,98	2072,02	2207,98	2.141,2	-2,98	0,1%
13-10-2016	2132,6	10-21-16	2,49	2070	-2,5	0,16	2200	-0,2	2,65	2067,35	2202,65	2.141,2	-2,65	0,4%
14-10-2016	2133,0	10-21-16	1,5	2070	-1,5	0,1	2200	-0,1	1,6	2068,4	2201,6	2.141,2	-1,60	0,4%
17-10-2016	2126,5	10-21-16	0,6	2060	-0,6	0,05	2190	-0,1	0,65	2059,35	2190,65	2.141,2	-0,65	0,7%
18-10-2016	2139,6	10-21-16	0,25	2075	-0,3	0,1	2205	-0,1	0,35	2074,65	2205,35	2.141,2	-0,35	0,1%
19-10-2016	2144,3	10-21-16	0,2	2080	-0,2	0,05	2210	-0,1	0,25	2079,75	2210,25	2.141,2	-0,25	-0,1%
20-10-2016	2141,3	10-21-16	0,1	2075	-0,1	0,05	2205	-0,1	0,15	2074,85	2205,15	2.141,2	-0,15	0,0%
21-10-2016	2141,2	10-21-16	0	2075	0,0	0	2205	0,0	0	2075	2205	2.141,2	-	0,0%

LONG STRANGLE 2

Underlying asset: S&P 500

Expiration date: 18-11-2016

S&P500																
Buy date	Spot price at Buy date	Expiry date	Long Put (ITM)				Long Call (OTM)				Net premium paid	Downside breakeven point	Upside breakeven point	Spot price S&P at maturity	Payoff (in USD)	Percentage difference between spot prices
			Put premium paid (ask)	Long put strike price K1 (ITM)	Payoff Long call	Call premium paid (ask)	Long call strike price K2 (OTM)	Payoff Long put								
18-05-2016	2048,0	11-18-16	0	1990	-	0	2110	-	0	1990	2110	2.181,9	-	-	-	-
18-08-2016	2187,0	11-18-16	37,8	2120	-37,8	17,35	2250	-17,4	55,15	2064,85	2305,15	2.181,9	-55,15	-0,2%		
21-10-2016	2141,2	11-18-16	11,7	2075	-11,7	2,34	2205	-2,3	14,04	2060,96	2219,04	2.181,9	-14,04	1,9%		
24-10-2016	2151,3	11-18-16	10,3	2085	-10,3	1,48	2215	-1,5	11,78	2073,22	2226,78	2.181,9	-11,78	1,4%		
25-10-2016	2143,2	11-18-16	11,35	2080	-11,4	1,85	2210	-1,9	13,2	2066,8	2223,2	2.181,9	-13,20	1,8%		
26-10-2016	2139,4	11-18-16	12,5	2075	-12,5	2,35	2205	-2,4	14,85	2060,15	2219,85	2.181,9	-14,85	2,0%		
27-10-2016	2133,0	11-18-16	13,7	2070	-13,7	2,55	2200	-2,6	16,25	2053,75	2216,25	2.181,9	-16,25	2,3%		
28-10-2016	2126,4	11-18-16	13,15	2060	-13,2	3,85	2190	-3,9	17	2043	2207	2.181,9	-17,00	2,6%		
31-10-2016	2126,1	11-18-16	14	2060	-14,0	3,75	2190	-3,8	17,75	2042,25	2207,75	2.181,9	-17,75	2,6%		
01-11-2016	2111,7	11-18-16	15,35	2045	-15,4	5	2175	1,9	20,35	2024,65	2195,35	2.181,9	-13,45	3,3%		
02-11-2016	2097,9	11-18-16	15,31	2035	-15,3	5,5	2165	11,4	20,81	2014,19	2185,81	2.181,9	-3,91	4,0%		
03-11-2016	2088,7	11-18-16	18,76	2025	-18,8	6,55	2155	20,3	25,31	1999,69	2180,31	2.181,9	1,59	4,5%		
04-11-2016	2085,2	11-18-16	19,3	2020	-19,3	7,41	2150	24,5	26,71	1993,29	2176,71	2.181,9	5,19	4,6%		
07-11-2016	2131,5	11-18-16	14,4	2065	-14,4	2,4	2195	-2,4	16,8	2048,2	2211,8	2.181,9	-16,80	2,4%		
08-11-2016	2139,6	11-18-16	13,97	2075	-14,0	1,99	2205	-2,0	15,96	2059,04	2220,96	2.181,9	-15,96	2,0%		
09-11-2016	2163,3	11-18-16	4,4	2100	-4,4	0,4	2230	-0,4	4,8	2095,2	2234,8	2.181,9	-4,80	0,9%		
10-11-2016	2167,5	11-18-16	3,29	2100	-3,3	0,39	2230	-0,4	3,68	2096,32	2233,68	2.181,9	-3,68	0,7%		
11-11-2016	2164,4	11-18-16	2,25	2100	-2,3	0,3	2230	-0,3	2,55	2097,45	2232,55	2.181,9	-2,55	0,8%		
14-11-2016	2164,2	11-18-16	0,55	2060	-0,6	1,15	2190	-1,2	1,7	2058,3	2191,7	2.181,9	-1,70	0,8%		
15-11-2016	2180,4	11-18-16	0,25	2075	-0,3	1,1	2205	-1,1	1,35	2073,65	2206,35	2.181,9	-1,35	0,1%		
16-11-2016	2176,9	11-18-16	0,25	2080	-0,3	0,25	2210	-0,3	0,5	2079,5	2210,5	2.181,9	-0,50	0,2%		
17-11-2016	2187,1	11-18-16	0,1	2075	-0,1	0,35	2205	-0,4	0,45	2074,55	2205,45	2.181,9	-0,45	-0,2%		
18-11-2016	2181,9	11-18-16	0	2075	0,0	0	2205	0,0	0	2075	2205	2.181,9	-	-		

LONG STRANGLE 3

Underlying asset: S&P 500

Expiration date: 16-12-2016

S&P500														
Buy date	Spot price at Buy date	Expiry date	Long Put (ITM)			Long Call (OTM)			Net premium paid	Downside breakeven in point	Upside breakeven point	Spot price S&P at maturity	Payoff (in USD)	Percentage difference between spot prices
			Put premium paid (ask)	Long put strike price K1 (ITM)	Payoff Long call	Call premium paid (ask)	Long call strike price K2 (OTM)	Payoff Long put						
16-06-2016	2078,0	12-16-16	0	2020	-	0	2140	-	0	2020	2140	2.258,1	-	-
16-09-2016	2147,3	12-16-16	45,4	2075	-	0	2205	-	45,4	2029,6	2250,4	2.258,1	-	-
18-11-2016	2181,9	12-16-16	9,52	2115	-9,5	2,85	2245	10,2	12,37	2102,63	2257,37	2.258,1	0,70	3,5%
21-11-2016	2198,2	12-16-16	8,37	2135	-8,4	1,5	2265	-1,5	9,87	2125,13	2274,87	2.258,1	-9,87	2,7%
22-11-2016	2202,9	12-16-16	7,95	2140	-8,0	1,55	2270	-1,6	9,5	2130,5	2279,5	2.258,1	-9,50	2,5%
23-11-2016	2204,7	12-16-16	7,7	2140	-7,7	1,63	2270	-1,6	9,33	2130,67	2279,33	2.258,1	-9,33	2,4%
25-11-2016	2213,4	12-16-16	7,05	2150	-7,1	1,33	2280	-1,3	8,38	2141,62	2288,38	2.258,1	-8,38	2,0%
28-11-2016	2201,7	12-16-16	6,45	2135	-6,5	1,55	2265	-1,6	8	2127	2273	2.258,1	-8,00	2,6%
29-11-2016	2204,7	12-16-16	6,4	2140	-6,4	1,11	2270	-1,1	7,51	2132,49	2277,51	2.258,1	-7,51	2,4%
30-11-2016	2198,8	12-16-16	6,3	2135	-6,3	1,3	2265	-1,3	7,6	2127,4	2272,6	2.258,1	-7,60	2,7%
01-12-2016	2191,1	12-16-16	6,2	2125	-6,2	1,55	2255	1,5	7,75	2117,25	2262,75	2.258,1	-4,68	3,1%
02-12-2016	2191,9	12-16-16	6	2125	-6,0	1,24	2255	1,8	7,24	2117,76	2262,24	2.258,1	-4,17	3,0%
05-12-2016	2204,7	12-16-16	2,73	2140	-2,7	0,4	2270	-0,4	3,13	2136,87	2273,13	2.258,1	-3,13	2,4%
06-12-2016	2212,2	12-16-16	1,8	2145	-1,8	0,3	2275	-0,3	2,1	2142,9	2277,1	2.258,1	-2,10	2,1%
07-12-2016	2241,4	12-16-16	1,85	2175	-1,9	0,7	2305	-0,7	2,55	2172,45	2307,55	2.258,1	-2,55	0,7%
08-12-2016	2246,2	12-16-16	1,72	2180	-1,7	0,63	2310	-0,6	2,35	2177,65	2312,35	2.258,1	-2,35	0,5%
09-12-2016	2259,5	12-16-16	0,91	2190	-0,9	0,55	2330	-0,6	1,46	2188,54	2331,46	2.258,1	-1,46	-0,1%
12-12-2016	2257,0	12-16-16	0,75	2185	-0,8	0,2	2325	-0,2	0,95	2184,05	2325,95	2.258,1	-0,95	0,0%
13-12-2016	2271,7	12-16-16	0,5	2200	-0,5	0,33	2340	-0,3	0,83	2199,17	2340,83	2.258,1	-0,83	-0,6%
14-12-2016	2253,3	12-16-16	0,6	2185	-0,6	0,15	2325	-0,2	0,75	2184,25	2325,75	2.258,1	-0,75	0,2%
15-12-2016	2262,0	12-16-16	0,25	2190	-0,3	0,05	2330	-0,1	0,3	2189,7	2330,3	2.258,1	-0,30	-0,2%
16-12-2016	2258,1	12-16-16	0	2190	0,0	0	2330	0,0	0	2190	2330	2.258,1	-	-

LONG STRANGLE – Results Summary

LONG STRANGLE 1 SPX (10-21-16)	Nr of trades	Value of trades
Positive results	0	-
Negative results	21	- 168
TOTAL (Added value)	21	- 168

LONG STRANGLE 2 SPX (11-18-16)	Nr of trades	Value of trades
Positive results	2	7
Negative results	19	- 225
TOTAL (Added value)	21	- 218

LONG STRANGLE 3 SPX (12-16-16)	Nr of trades	Value of trades
Positive results	1	1
Negative results	18	- 83
TOTAL (Added value)	19	- 83

LONG STRANGLE	Nr of trades	Value of trades
Positive results	3	7
Negative results	58	- 477
TOTAL (Added value)	61	- 469

SHORT BUTTERFLY SPREAD WITH CALLS 1

Underlying asset: S&P 500

Expiration date: 21-10-2016

USA Elections: 9th November, 2016																
S&P500																
Buy date	Spot price at Buy date	Expiry date	Short Call (ITM)			Short call (OTM)			2 Long Call (ATM)			Upside breakeven n point	Spot price S&P at maturity	Payoff (in USD)	Percentage difference between spot prices	
			Call premium received (bid)	Short Call strike price K1 (ITM)	Payoff Short Call (ITM)	Call premium received (bid)	Short Call strike price K2 (OTM)	Payoff Short call (OTM)	Call premium paid (ask)	Long Call strike price K' (ATM)	Payoff Long Call (ATM)					Net premium received
21-04-2016	2091.0	10-21-16	0	2005	-	0	2175	-	0	2090	-	2005.0	2175.0	2.141,2	-	-
21-07-2016	2165.0	10-21-16	107,45	2080	-	12,25	2250	-	0	2165	-	2080.0	2250.0	2.141,2	-	-
23-09-2016	2164,7	10-21-16	92,2	2080	31,0	0,55	2250	0,6	24,32	2165	-48,6	2124,1	2205,9	2.141,2	-17,05	1,9%
26-09-2016	2146,1	10-21-16	93,9	2060	12,7	0,97	2230	1,0	29,2	2145	-58,4	2096,5	2193,5	2.141,2	-44,69	2,2%
27-09-2016	2159,9	10-21-16	87,25	2075	21,1	0,43	2245	0,4	23,06	2160	-46,1	2116,6	2203,4	2.141,2	-24,60	2,0%
28-09-2016	2171,4	10-21-16	0	2085	-	0,3	2255	0,3	22,5	2170	-45,0	2085,0	2255,0	2.141,2	-	3,9%
29-09-2016	2151,1	10-21-16	0	2065	-	0,5	2235	0,5	29,08	2150	-58,2	2065,0	2235,0	2.141,2	-	3,9%
30-09-2016	2168,3	10-21-16	89,7	2085	33,5	0,2	2255	0,2	21,4	2170	-42,8	2132,1	2207,9	2.141,2	-9,060	1,8%
03-10-2016	2161,2	10-21-16	85,55	2075	19,4	0,26	2245	0,3	21,8	2160	-43,6	2117,2	2202,8	2.141,2	-23,95	1,9%
04-10-2016	2150,5	10-21-16	0	2065	-	0,3	2235	0,3	22,2	2150	-44,4	2065,0	2235,0	2.141,2	-	3,9%
05-10-2016	2159,7	10-21-16	87,73	2075	21,6	0,2	2245	0,2	19,35	2160	-38,7	2124,2	2195,8	2.141,2	-16,93	1,7%
06-10-2016	2160,8	10-21-16	86,6	2075	20,4	0,15	2245	0,2	20	2160	-40,0	2121,8	2198,3	2.141,2	-19,41	1,7%
07-10-2016	2153,7	10-21-16	89,2	2070	18,0	0,15	2240	0,2	17	2155	-34,0	2125,4	2184,7	2.141,2	-15,81	1,4%
10-10-2016	2163,7	10-21-16	89,3	2080	28,1	0,05	2250	0,1	13,4	2165	-26,8	2142,6	2187,5	2.141,2	1,39	1,1%
11-10-2016	2136,7	10-21-16	90,4	2050	-0,8	0,1	2220	0,1	20,2	2135	-28,1	2100,1	2169,9	2.141,2	-28,74	1,6%
12-10-2016	2139,2	10-21-16	0	2055	-	0,1	2225	0,1	16,21	2140	-30,1	2055,0	2225,0	2.141,2	-	4,0%
13-10-2016	2132,6	10-21-16	88,55	2050	-2,6	0,05	2220	0,1	15	2135	-17,7	2108,6	2161,4	2.141,2	-20,24	1,4%
14-10-2016	2133,0	10-21-16	85,66	2050	-5,5	0,05	2220	0,1	12,9	2135	-13,5	2109,9	2160,1	2.141,2	-18,93	1,3%
17-10-2016	2126,5	10-21-16	0	2040	-	0,02	2210	0,0	14,5	2125	3,3	2040,0	2210,0	2.141,2	-	3,9%
18-10-2016	2139,6	10-21-16	85,72	2055	-0,4	0,05	2225	0,1	8	2140	-13,7	2124,8	2155,2	2.141,2	-14,07	0,7%
19-10-2016	2144,3	10-21-16	85,29	2060	4,1	0,05	2230	0,1	5,84	2145	-11,7	2133,7	2156,3	2.141,2	-7,50	0,6%
20-10-2016	2141,3	10-21-16	88,63	2055	2,5	0,05	2225	0,1	5,6	2140	-8,9	2132,5	2147,5	2.141,2	-6,36	0,3%
21-10-2016	2141,2	10-21-16	0	2055	-86,2	0	2225	0,0	0	2140	2,3	2055,0	2225,0	2.141,2	-	3,9%

SHORT BUTTERFLY SPREAD WITH CALLS 2

Underlying asset: S&P 500

Expiration date: 18-11-2016

S&P500																		
Buy date	Spot price at Buy date	Expiry date	Short Call (ITM)			Short call (OTM)			2 Long Call (ATM)				Net premium received	Downside breakeven point	Upside breakeven point	Spot price S&P at maturity	Payoff (in USD)	Percentage difference between spot prices
			Call premium received (bid)	Short Call strike price K1 (ITM)	Payoff Short Call (ITM)	Call premium received (bid)	Short Call strike price K2 (OTM)	Payoff Short call (OTM)	Call premium paid (ask)	Long Call strike price K' (ATM)	Payoff Long Call (ATM)							
18-05-2016	2048,0	11-18-16	0	1970	-	0	2130	-	0	2050	-	-	-	-	-	-	-	-
18-08-2016	2187,0	11-18-16	108,2	2100	-	0	2270	-	0	2185	-	-	-	-	-	2.181,9	-	1,9%
19-10-2016	2141,2	11-18-16	96,4	2055	-30,5	1,53	2225	1,5	31,8	2140	20,2	34,33	2089,3	2190,7	2.181,9	-8,77	-	
24-10-2016	2151,3	11-18-16	0	2065	-	0,58	2235	-	23,52	2150	-	-	-	-	-	-	-	-
25-10-2016	2143,2	11-18-16	88,5	2060	-33,4	0,75	2230	0,8	24	2145	25,8	41,25	2101,3	2188,8	2.181,9	-6,85	1,8%	
26-10-2016	2139,4	11-18-16	0	2055	-	0,7	2225	-	26,7	2140	-	-	-	-	-	-	-	-
27-10-2016	2133,0	11-18-16	87,8	2050	-44,1	0,9	2220	0,9	26	2135	41,8	36,7	2086,7	2183,3	2.181,9	-1,40	2,3%	
28-10-2016	2126,4	11-18-16	94,1	2040	-47,8	1,2	2210	1,2	32,4	2125	49,0	30,5	2070,5	2179,5	2.181,9	2,40	2,6%	
31-10-2016	2126,1	11-18-16	95,95	2040	-45,9	1,4	2210	1,4	30,77	2125	52,3	35,81	2075,8	2174,2	2.181,9	7,71	2,6%	
01-11-2016	2111,7	11-18-16	97,1	2025	-59,8	1,85	2195	1,9	32,5	2110	78,8	33,95	2059,0	2161,1	2.181,9	20,85	3,3%	
02-11-2016	2097,9	11-18-16	93,6	2015	-73,3	1,95	2185	2,0	31,1	2100	101,6	33,35	2048,4	2151,7	2.181,9	30,25	4,0%	
03-11-2016	2088,7	11-18-16	98,28	2005	-78,6	2,9	2175	-4,0	34,4	2090	115,0	32,38	2037,4	2142,6	2.181,9	32,38	4,5%	
04-11-2016	2085,2	11-18-16	99	2000	-82,9	3,5	2170	-8,4	37	2085	119,8	28,5	2028,5	2141,5	2.181,9	28,50	4,6%	
07-11-2016	2131,5	11-18-16	82,7	2045	-54,2	0,75	2215	0,8	30,8	2130	42,2	21,85	2066,9	2193,2	2.181,9	-11,25	2,4%	
08-11-2016	2139,6	11-18-16	0	2055	-	0,7	2225	-	25,5	2140	-	-	-	-	-	-	-	-
09-11-2016	2163,3	11-18-16	86,95	2080	-14,9	0,3	2250	0,3	15,94	2165	1,9	55,37	2135,4	2194,6	2.181,9	-12,73	0,9%	
10-11-2016	2167,5	11-18-16	99,35	2080	-2,5	0,15	2250	0,2	16,5	2165	0,8	66,5	2146,5	2183,5	2.181,9	-1,60	0,7%	
11-11-2016	2164,4	11-18-16	82,6	2080	-19,3	0,2	2250	0,2	12,49	2165	8,8	57,82	2137,8	2192,2	2.181,9	-10,28	0,8%	
14-11-2016	2164,2	11-18-16	126,2	2040	-15,7	0,28	2210	0,3	39,5	2125,0	34,8	47,48	2087,5	2162,5	2.181,9	19,38	0,8%	
15-11-2016	2180,4	11-18-16	116,03	2055	-10,9	0,3	2225	0,3	39	2140,0	5,8	38,33	2093,3	2186,7	2.181,9	-4,77	0,1%	
16-11-2016	2176,9	11-18-16	0	2060	-	0,23	2230	-	31,49	2145,0	-	-	-	-	-	-	-	-
17-11-2016	2187,1	11-18-16	131,5	2055	4,6	0,1	2225	0,1	45,5	2140,0	-7,2	40,6	2095,6	2184,4	2.181,9	-2,50	-0,2%	
18-11-2016	2181,9	11-18-16	0	2055	-	0	2225	0,0	0	2140,0	83,8	0	2055,0	2225,0	2.181,9	-	0,0%	

SHORT BUTTERFLY SPREAD WITH CALLS 3

Underlying asset: S&P 500

Expiration date: 16-12-2016

S&P500																	
Buy date	Spot price at Buy date	Expiry date	Short Call (ITM)			Short call (OTM)			2 Long Call (ATM)			Upside breakeven n point	Downside breakeven point	Spot price breakeven S&P at maturity	Payoff (in USD)	Percentage difference between spot prices	
			Call premium received (bid)	Short Call strike price K1 (ITM)	Payoff Short Call (ITM)	Call premium received (bid)	Short Call strike price K2 (OTM)	Payoff Short call (OTM)	Call premium paid (ask)	Long Call strike price K' (ATM)	Payoff Long Call (ATM)						Net premium received
16-06-2016	2078,0	12-16-16	0	1995	-	0	2165	-	0	2080	-	109,1	18,4	2165,0	2.258,1	-	-
15-09-2016	2147,3	12-16-16	125,2	2055	-77,9	20,2	2225	-12,9	63,5	2140	109,1	18,4	2073,4	206,6	2.258,1	18,40	5,2%
18-11-2016	2181,9	12-16-16	92,4	2095	-70,7	1,35	2265	1,4	26,1	2180	103,9	41,55	2136,55	223,5	2.258,1	34,62	3,5%
21-11-2016	2198,2	12-16-16	88,92	2110	-59,2	0,65	2290	0,7	19,7	2200	76,7	50,17	2160,17	2239,8	2.258,1	18,24	2,7%
22-11-2016	2202,9	12-16-16	0	2115	-	0	2295	-	20,8	2205	-	0	2115	2295,0	2.258,1	-	-
23-11-2016	2204,7	12-16-16	85	2115	-58,1	0,7	2295	0,7	20,1	2205	65,9	45,5	2160,5	2249,5	2.258,1	8,57	2,4%
25-11-2016	2213,4	12-16-16	89,5	2125	-43,6	0,75	2305	0,8	19,16	2215	47,8	51,93	2176,93	2253,1	2.258,1	5,00	2,0%
28-11-2016	2201,7	12-16-16	97,8	2110	-50,3	0,75	2290	0,8	21,5	2200	73,1	55,55	2165,55	2234,5	2.258,1	23,62	2,6%
29-11-2016	2204,7	12-16-16	97	2115	-46,1	0,55	2295	0,6	20	2205	66,1	57,55	2172,55	2237,5	2.258,1	20,62	2,4%
30-11-2016	2198,8	12-16-16	97,01	2110	-51,1	0,5	2290	0,5	21	2200	74,1	55,51	2165,51	2234,5	2.258,1	23,58	2,7%
01-12-2016	2191,1	12-16-16	91,13	2100	-66,9	0,55	2280	0,6	23	2190	90,1	45,68	2145,68	2234,3	2.258,1	23,75	3,1%
02-12-2016	2191,9	12-16-16	94,86	2100	-63,2	0,48	2280	0,5	21	2190	94,1	53,34	2153,34	2226,7	2.258,1	31,41	3,0%
05-12-2016	2204,7	12-16-16	92,7	2115	-50,4	0,4	2295	0,4	14	2205	78,1	65,1	2180,1	2229,9	2.258,1	28,17	2,4%
06-12-2016	2212,2	12-16-16	89,5	2120	-48,6	0,15	2300	0,2	14	2210	68,1	61,65	2181,65	2238,4	2.258,1	19,72	2,1%
07-12-2016	2241,4	12-16-16	90,5	2150	-17,6	0	2330	0,0	13	2240	10,1	64,5	2214,5	2265,5	2.258,1	-	-
08-12-2016	2246,2	12-16-16	89,6	2155	-13,5	0	2335	0,0	15,57	2245	-5,0	58,46	2213,46	2276,5	2.258,1	-	-
09-12-2016	2259,5	12-16-16	88,6	2170	0,5	0,3	2350	0,3	11,53	2260	-23,1	65,84	2235,84	2284,2	2.258,1	-22,23	-0,1%
12-12-2016	2257,0	12-16-16	92,57	2165	-0,5	0,25	2345	0,3	11,5	2255	-16,9	69,82	2234,82	2275,2	2.258,1	-17,11	0,0%
13-12-2016	2271,7	12-16-16	92	2180	13,9	0,25	2360	0,3	11,6	2270	-23,2	69,05	2249,05	2291,0	2.258,1	-9,02	-0,6%
14-12-2016	2253,3	12-16-16	89,37	2165	-3,7	0,1	2345	0,1	8,33	2255	-10,5	72,81	2237,81	2272,2	2.258,1	-14,12	0,2%
15-12-2016	2262,0	12-16-16	94,06	2170	6,0	0,05	2350	0,1	6,5	2260	-13,0	81,11	2251,11	2268,9	2.258,1	-6,96	-0,2%
16-12-2016	2258,1	12-16-16	0	2170	-88,1	0	2350	0,0	0	2260	0,0	0,0	2170	2350,0	2.258,1	-	-

SHORT BUTTERFLY SPREAD WITH CALLS – Results Summary

SHORT BUT. S. W/ CALLS 1 SPX (10-21-16)	Nr of trades	Value of trades
Positive results	1	1
Negative results	14	- 267
TOTAL (Added value)	15	- 266

SHORT BUT. S. W/ CALLS 2 SPX (18-11-16)	Nr of trades	Value of trades
Positive results	7	141
Negative results	9	- 60
TOTAL (Added value)	16	81

SHORT BUT. S. W/ CALLS 3 SPX (12-16-16)	Nr of trades	Value of trades
Positive results	12	256
Negative results	5	- 69
TOTAL (Added value)	17	186

S. BUTTERFLY SPREAD W/ CALLS	Nr of trades	Value of trades
Positive results	20	399
Negative results	28	- 397
TOTAL (Added value)	48	2

Appendix 3⁵

Historical volatility calculations

Footsie 100 index

VOL FTSE (17-06-16)			
Date	Price	Change	LN
20-05-16	6.156,3	0	0
23-05-16	6.136,4	0,9968	-0,0032
24-05-16	6.219,3	1,0135	0,0134
25-05-16	6.262,9	1,0070	0,0070
26-05-16	6.265,7	1,0004	0,0004
27-05-16	6.270,8	1,0008	0,0008
31-05-16	6.230,8	0,9936	-0,0064
01-06-16	6.191,9	0,9938	-0,0063
02-06-16	6.185,6	0,9990	-0,0010
03-06-16	6.209,6	1,0039	0,0039
06-06-16	6.273,4	1,0103	0,0102
07-06-16	6.284,5	1,0018	0,0018
08-06-16	6.301,5	1,0027	0,0027
09-06-16	6.231,9	0,9890	-0,0111
10-06-16	6.115,8	0,9814	-0,0188
13-06-16	6.045,0	0,9884	-0,0116
14-06-16	5.923,5	0,9799	-0,0203
15-06-16	5.966,8	1,0073	0,0073
16-06-16	5.950,5	0,9973	-0,0027
17-06-16	6.021,1	1,0119	0,0118
Historical volatility FTSE 100 (period: 20 days)			14,80%

VOL FTSE (15-07-16)			
Date	Price	Change	LN
17-06-16	6.021,1	0	0
20-06-16	6.204,0	1,0304	0,02993
21-06-16	6.226,6	1,0036	0,00363
22-06-16	6.261,2	1,0056	0,00555
23-06-16	6.338,1	1,0123	0,01221
24-06-16	6.138,7	0,9685	-0,03197
27-06-16	5.982,2	0,9745	-0,02582
28-06-16	6.140,4	1,0264	0,02610
29-06-16	6.360,1	1,0358	0,03515
30-06-16	6.504,3	1,0227	0,02243
01-07-16	6.577,8	1,0113	0,01124
04-07-16	6.522,3	0,9916	-0,00848
05-07-16	6.545,4	1,0035	0,00354
06-07-16	6.463,6	0,9875	-0,01257
07-07-16	6.533,8	1,0109	0,01080
08-07-16	6.590,6	1,0087	0,00866
11-07-16	6.682,9	1,0140	0,01390
12-07-16	6.680,7	0,9997	-0,00032
13-07-16	6.670,4	0,9985	-0,00154
14-07-16	6.654,5	0,9976	-0,00239
15-07-16	6.669,2	1,0022	0,00222
Historical volatility FTSE 100 (period: 21 days)			26,24%

⁵ All the data regarding the option prices and index prices, was exported from *Bloomberg*

Testing high volatility expectation trades – 2016 events

DAX 30 index

VOL DAX (17-06-16)			
Date	Price	Change	LN
20-05-16	9.916,0	0	0
23-05-16	9.842,3	0,992565	-0,00746
24-05-16	10.057,3	1,021847	0,021611
25-05-16	10.205,2	1,014706	0,014599
26-05-16	10.272,7	1,006614	0,006592
27-05-16	10.286,3	1,001324	0,001323
30-05-16	10.333,2	1,004561	0,004551
31-05-16	10.262,7	0,993178	-0,00685
01-06-16	10.204,4	0,994319	-0,0057
02-06-16	10.208,0	1,000349	0,000349
03-06-16	10.103,3	0,989739	-0,01031
06-06-16	10.121,1	1,001764	0,001762
07-06-16	10.287,7	1,016461	0,016327
08-06-16	10.217,0	0,993133	-0,00689
09-06-16	10.088,9	0,987456	-0,01262
10-06-16	9.834,6	0,974799	-0,02552
13-06-16	9.657,4	0,981984	-0,01818
14-06-16	9.519,2	0,985686	-0,01442
15-06-16	9.606,7	1,009193	0,009151
16-06-16	9.550,5	0,994146	-0,00587
17-06-16	9.631,4	1,00847	0,008434
Historical volatility DAX 30 (period: 21 days)			18,79%

VOL DAX (15-07-16)			
Date	Price	Change	LN
17-06-16	9.631,4	0	0
20-06-16	9.962,0	1,0343316	0,0337554
21-06-16	10.015,5	1,0053724	0,005358
22-06-16	10.071,1	1,00554339	0,0055281
23-06-16	10.257,0	1,01846578	0,0182974
24-06-16	9.557,2	0,9317668	-0,0706727
27-06-16	9.268,7	0,96981321	-0,0306518
28-06-16	9.447,3	1,01927139	0,0190881
29-06-16	9.612,3	1,01746429	0,0173135
30-06-16	9.680,1	1,00705557	0,0070308
01-07-16	9.776,1	1,00992036	0,0098715
04-07-16	9.709,1	0,99314348	-0,0068801
05-07-16	9.532,6	0,98182327	-0,018344
06-07-16	9.373,3	0,98328364	-0,0168577
07-07-16	9.418,8	1,00485642	0,0048447
08-07-16	9.629,7	1,0223893	0,0221423
11-07-16	9.833,4	1,02115859	0,0209379
12-07-16	9.964,1	1,01328737	0,0131999
13-07-16	9.930,7	0,99665194	-0,0033537
14-07-16	10.068,3	1,01385499	0,0137599
15-07-16	10.066,9	0,99986101	-0,000139
Historical volatility DAX 30 (period: 21 days)			35,82%

Testing high volatility expectation trades – 2016 events

S&P 500 index

VOL S&P 500 (21-10-16)				VOL S&P 500 (18-11-16)			
Date	Price	Change	LN	Date	Price	Change	LN
23-09-16	2.165	0	0	21-10-16	2.141	0	0
26-09-16	2.146	0,9914	-0,0086	24-10-16	2.151	1,0047	0,0047
27-09-16	2.160	1,0064	0,0064	25-10-16	2.143	0,9962	-0,0038
28-09-16	2.171	1,0053	0,0053	26-10-16	2.139	0,9983	-0,0017
29-09-16	2.151	0,9907	-0,0094	27-10-16	2.133	0,9970	-0,0030
30-09-16	2.168	1,0080	0,0079	28-10-16	2.126	0,9969	-0,0031
03-10-16	2.161	0,9967	-0,0033	31-10-16	2.126	0,9999	-0,0001
04-10-16	2.150	0,9950	-0,0050	01-11-16	2.112	0,9932	-0,0068
05-10-16	2.160	1,0043	0,0043	02-11-16	2.098	0,9935	-0,0065
06-10-16	2.161	1,0005	0,0005	03-11-16	2.089	0,9956	-0,0044
07-10-16	2.154	0,9967	-0,0033	04-11-16	2.085	0,9983	-0,0017
10-10-16	2.164	1,0046	0,0046	07-11-16	2.132	1,0222	0,0220
11-10-16	2.137	0,9876	-0,0125	08-11-16	2.140	1,0038	0,0038
12-10-16	2.139	1,0011	0,0011	09-11-16	2.163	1,0111	0,0110
13-10-16	2.133	0,9969	-0,0031	10-11-16	2.167	1,0020	0,0019
14-10-16	2.133	1,0002	0,0002	11-11-16	2.164	0,9986	-0,0014
17-10-16	2.127	0,9970	-0,0030	14-11-16	2.164	0,9999	-0,0001
18-10-16	2.140	1,0062	0,0061	15-11-16	2.180	1,0075	0,0075
19-10-16	2.144	1,0022	0,0022	16-11-16	2.177	0,9984	-0,0016
20-10-16	2.141	0,9986	-0,0014	17-11-16	2.187	1,0047	0,0047
21-10-16	2.141	0,9999	-0,0001	18-11-16	2.182	0,9976	-0,0024
Historical volatility S&P 500 (period: 21 days)			8,66%	Historical volatility S&P 500 (period: 21 days)			10,43%

Testing high volatility expectation trades – 2016 events

VOL S&P 500 (16-12-16)			
Date	Price	Change	LN
18-11-16	2.182	0	0
21-11-16	2.198	1,0075	0,0074
22-11-16	2.203	1,0022	0,0022
23-11-16	2.205	1,0008	0,0008
25-11-16	2.213	1,0039	0,0039
28-11-16	2.202	0,9947	-0,0053
29-11-16	2.205	1,0013	0,0013
30-11-16	2.199	0,9973	-0,0027
01-12-16	2.191	0,9965	-0,0035
02-12-16	2.192	1,0004	0,0004
05-12-16	2.205	1,0058	0,0058
06-12-16	2.212	1,0034	0,0034
07-12-16	2.241	1,0132	0,0131
08-12-16	2.246	1,0022	0,0022
09-12-16	2.260	1,0059	0,0059
12-12-16	2.257	0,9989	-0,0011
13-12-16	2.272	1,0065	0,0065
14-12-16	2.253	0,9919	-0,0082
15-12-16	2.262	1,0039	0,0039
16-12-16	2.258	0,9982	-0,0018
Historical volatility S&P 500 (period: 20 days)			7,73%